

ASSEMBLING YOUR MACHINE

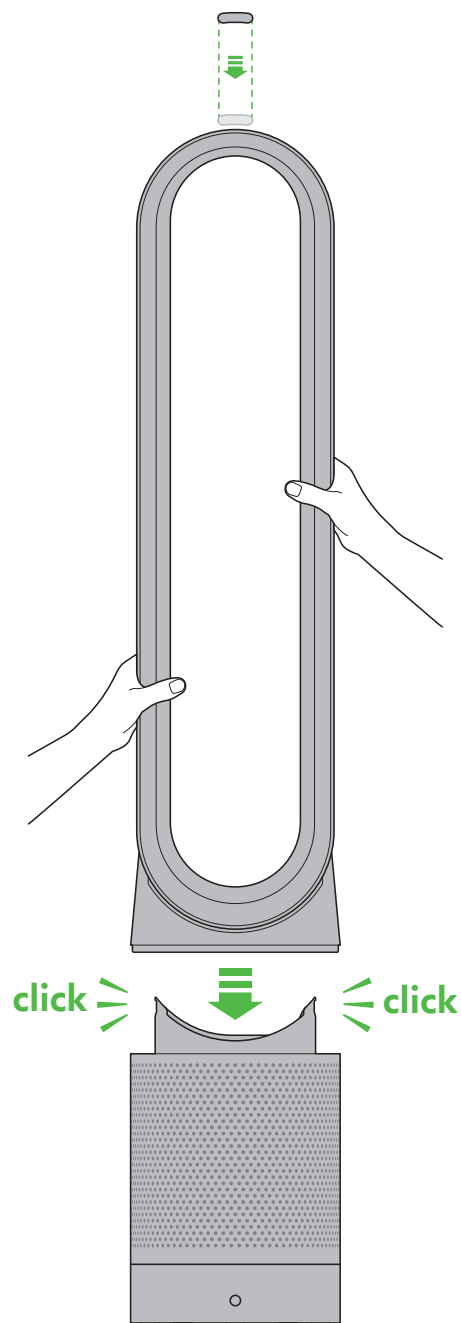

**REGISTER YOUR
DYSON 2-YEAR
GUARANTEE TODAY**



DYSON CUSTOMER CARE

THANK YOU FOR CHOOSING TO BUY A DYSON MACHINE

After registering your two-year Dyson guarantee, your Dyson machine will be covered for parts and labour (excluding replacement filters where there is no defect) for two years from the date of purchase, subject to the terms of the guarantee. If you have any questions about your Dyson machine, call the Dyson Helpline with your serial number and details of where and when you bought the machine. Most questions can be solved over the phone by one of our trained Dyson Helpline staff.

Your serial number can be found on your rating plate which is on the base of your machine.

Visit our website to register your Dyson full parts and labour guarantee online, and for online help, support videos, general tips and useful information about Dyson.

AU: www.dyson.com.au/support

NZ: www.dyson.co.nz/support

Note your serial number for future reference.



This illustration is for example purposes only.

2 EASY WAYS TO REGISTER YOUR DYSON 2-YEAR GUARANTEE



**REGISTER
ONLINE**
Visit our website to register your Dyson full parts and labour guarantee online.

AU: dyson.com.au/register
NZ: dyson.co.nz/register



**REGISTER
BY PHONE**
Call our dedicated Helpline.

AU: 1800 239 766
NZ: 0800 397 667

IMPORTANT SAFETY INSTRUCTIONS

BEFORE USING THIS APPLIANCE READ ALL INSTRUCTIONS AND CAUTIONARY MARKINGS IN THE USER MANUAL AND ON THE APPLIANCE.

When using an electrical appliance, basic precautions should always be followed, including the following:

WARNING

THE APPLIANCE AND THE REMOTE CONTROL BOTH CONTAIN MAGNETS.

1. Implanted medical devices such as pacemakers and defibrillators may be affected by strong magnetic fields. If you or someone in your household has an implanted medical device or defibrillator, avoid placing the remote control in a pocket or near to the device.
2. Credit cards and electronic storage media may also be affected by magnets and should be kept away from the remote control and the top of the appliance.

WARNING

These warnings apply to the appliance, and also where applicable, to all tools, accessories, chargers or mains adaptors.

TO REDUCE THE RISK OF FIRE, ELECTRIC SHOCK, OR INJURY:

1. This appliance is not intended for use by children, or persons with reduced physical, sensory or mental capabilities, or lack of experience and knowledge, unless they are supervised and/or given instruction by a responsible person concerning use of the appliance to ensure that they can use it safely. Cleaning and user maintenance should not be performed by children without supervision.
2. Ensure that the appliance is fully assembled in line with the instructions before use.
3. Do not allow to be used as a toy. Close attention is necessary when used by or near children. Children should be supervised to ensure that they do not play with the appliance.
4. Use only as described in the Dyson User manual. Do not carry out any maintenance other than that shown in the manual, or advised by the Dyson Helpline.
5. Suitable for dry locations ONLY. Do not use outdoors or on wet surfaces and do not expose to water or rain.
6. Do not handle any part of the plug or appliance with wet hands.
7. Do not operate any appliance with a damaged cable or plug. Discard the appliance or return to an authorised service facility for examination and/or repair. If the supply cable is damaged it must be replaced by Dyson, its service agent or similarly qualified persons in order to avoid a hazard.
8. If the appliance is not working as it should, if it has received a sharp blow, if it has been dropped, damaged, left outdoors, or dropped into water, do not use and contact the Dyson Helpline.
9. Do not stretch the cable or place the cable under strain. Keep cable away from heated surfaces.
10. Do not run cable under carpeting. Do not cover cable with throw rugs, runners or similar coverings. Arrange cable away from traffic areas and where it will not be tripped over.
11. Do not unplug by pulling on the cable. To unplug, grasp the plug, not the cable. Do not use with an extension lead.
12. Do not put any object into openings or the inlet grille. Do not use with any openings blocked; keep free of dust, lint, hair, and anything that may reduce airflow.
13. Do not use any cleaning agents or lubricants on this appliance. Unplug before cleaning or carrying out any maintenance.
14. Always carry the appliance by the base, do not carry it by the loop amplifier.
15. Turn off all controls before unplugging. Unplug from socket when not in use for extended periods. To avoid a tripping hazard, safely coil the cable.
16. Do not use near furnaces, fireplaces, stoves or other high temperature heat sources.

17. Do not use in conjunction with or directly next to an air freshener or similar products. Do not spray or apply perfumes directly on or near the filter. Keep essential oils and chemicals away from the appliance.
18. Chemical Burn and Choking Hazard. Keep batteries away from children. This product contains a lithium button/coin cell battery. If a new or used lithium button/coin cell battery is swallowed or enters the body, it can cause severe internal burns and can lead to death in as little as 2 hours. Always completely secure the battery compartment. If the battery compartment does not close securely, stop using the product, remove the batteries, and keep it away from children. If you think batteries might have been swallowed or placed inside any part of the body, seek immediate medical attention.

READ AND SAVE THESE INSTRUCTIONS

THIS DYSON APPLIANCE IS INTENDED FOR HOUSEHOLD USE ONLY



Do not pull on the cable.

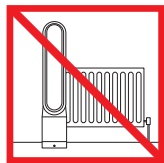

Do not store near heat sources.

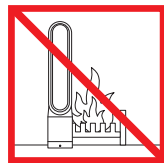

Do not use near naked flames.



Do not carry by the loop amplifier.



Do not spray scented products such as air freshener or perfume near the filter or the appliance.

Controls

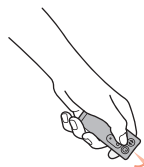

To operate, point the remote control toward the front of the base.



Standby on/off



Attach the remote control to the top of the machine with the buttons facing down.

Select a high flow of air.

Select a low flow of air.

Standby on/off

Airflow control

Oscillation on/off

Sleep timer

15

30

To set the sleep timer, select the desired time. When time reaches zero, the machine will go into Standby mode. To cancel, increase the time until two dashes appear.

When using the sleep timer, the LED display will turn off after 10 seconds of inactivity.

Cleaning

Clearing blockages

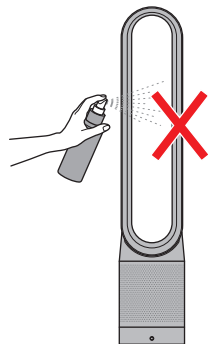
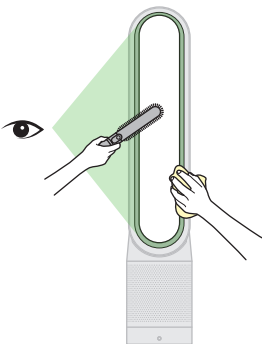

Ensure that the machine is unplugged. Dust may accumulate on the surface of the machine. Wipe dust from the loop amplifier, filter unit and other parts with a dry or damp cloth when dust accumulates. Do not use detergents or polishes to clean the machine.

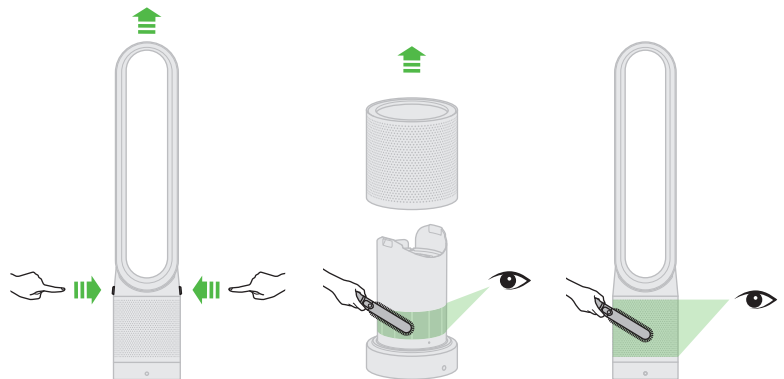

Ensure the machine is unplugged. Look for blockages in the air inlet holes and in the small aperture inside the air loop amplifier. Use a soft brush to remove debris.

Replacing the filter unit



When your non-washable filter unit needs replacing, the machine will display the pattern shown. To replace the non-washable filter unit, follow these steps. If the machine has been in use, leave for 1 to 2 hours before replacing the filter unit to allow the machine to cool down completely. Your machine is programmed to remind you to replace the filter unit after 12 months based on 12 hours usage a day. Please note your indicator will activate sooner with more use. The indicator is only a guide and you may need to replace the filter unit more regularly.

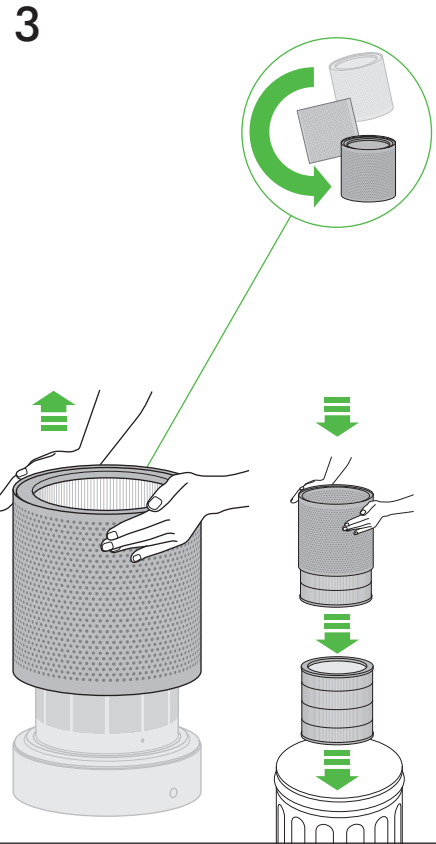
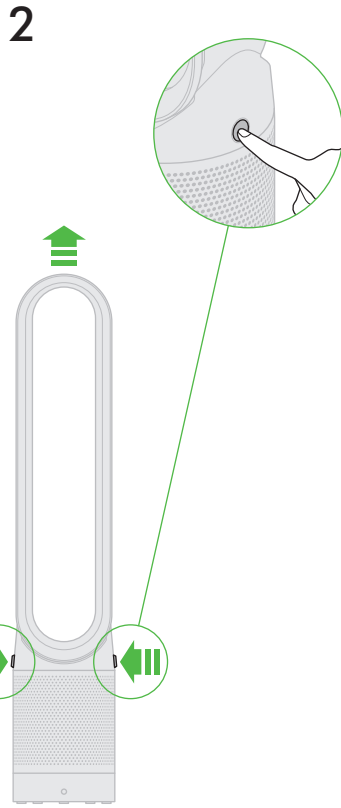
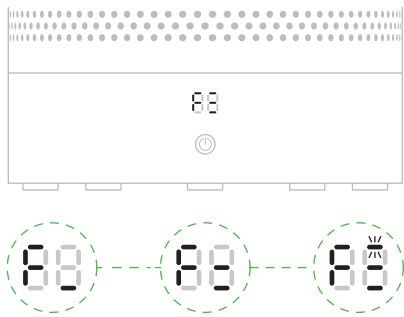

4 When disposing of the exhausted filter unit please do so in accordance with local regulations.

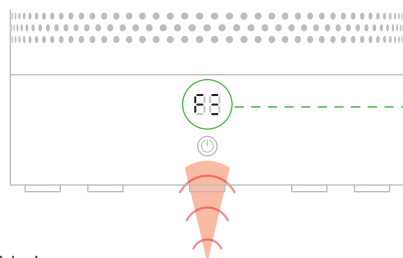
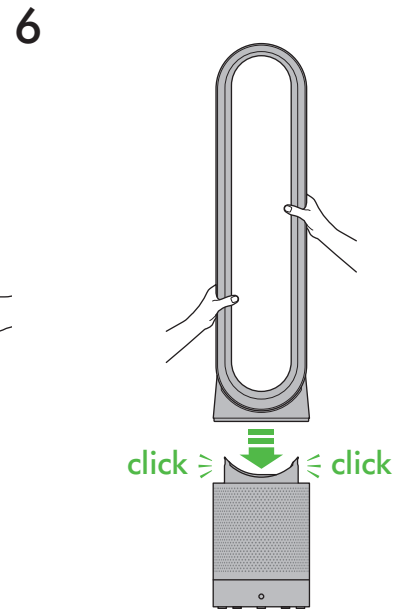
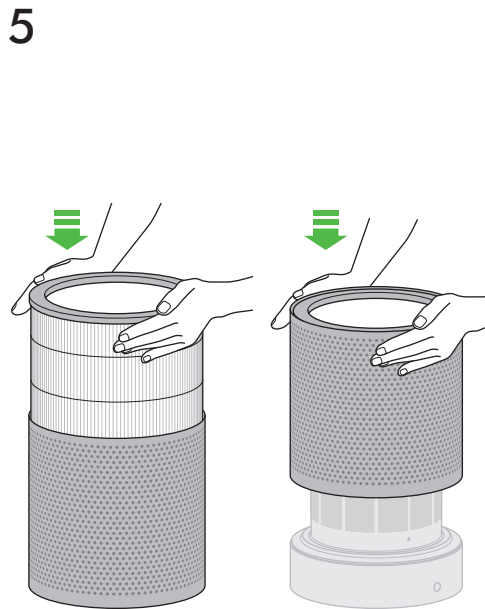
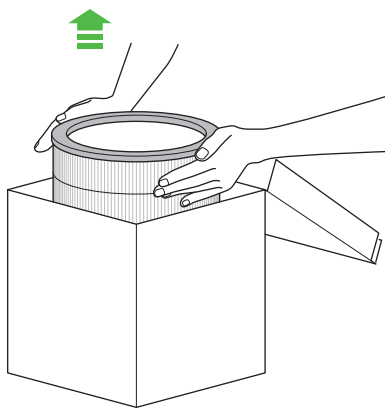

When you have reassembled your machine, press and hold the Standby on/off button for 6 seconds on the remote control to reset the filter indicator.

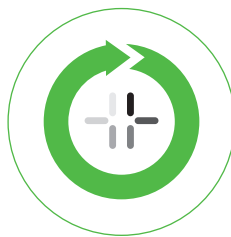

A clockwise-rotating loading pattern will be shown on the LED display.

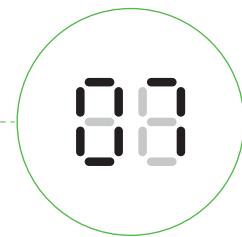

Once the loading pattern is complete, the machine will return to its normal usage.

USING YOUR DYSON MACHINE

PLEASE READ THE 'IMPORTANT SAFETY INSTRUCTIONS' IN YOUR DYSON USER MANUAL BEFORE PROCEEDING.

LOOKING AFTER YOUR DYSON MACHINE

- Do not carry out any maintenance or repair work other than that shown in your Dyson User manual, or advised by the Dyson Helpline.
- Always disconnect the plug from the mains before inspecting for problems. If the machine will not operate, first check that the mains socket has an electricity supply and that the plug is properly inserted into the socket.

CONTROL WITHOUT THE REMOTE

- Press the Standby on/off button on the machine to turn it on and off.
- Press and hold the Standby on/off button on the machine to adjust the airflow. Airflow will increase to a maximum before decreasing.
- The oscillation function and sleep timer cannot be operated without the remote control.

SLEEP TIMER

- To set the sleep timer, select the desired time. When time reaches zero, the machine will go into Standby mode. To cancel, increase the time until two dashes appear.
- When the sleep timer is on, do not press the Standby on/off button as this will deactivate the sleep timer and turn the machine off.

REPLACEABLE PARTS



BATTERY REPLACEMENT

CAUTION

- Unscrew the battery compartment on the remote control. Loosen the base and pull to remove the battery.
- Do not install backwards or short circuit the batteries.
- Do not attempt to dismantle or charge the batteries. Keep away from fire.
- Always replace the screw in the remote control and refer to the battery hazard in the warning section.
- Follow battery manufacturers' instructions when installing new batteries (battery type CR 2032).
- Limited functionality is available without the remote control (see 'Control without the remote').

DISPOSAL INFORMATION

Dyson products are made from high-grade recyclable materials. Please dispose of this product responsibly and recycle where possible.

When your Dyson machine reaches the end of its life, we can assist with its safe disposal. You can send your old Dyson machine back to us (at our cost) and we will organise for it to be recycled.*

*Please note that not all parts are recyclable. Recycling of parts is subject to the capabilities of third party suppliers. Available in Australia only.

Simply:

1. Box up your old Dyson machine.
2. Take the package to your local post office and send it to the address below:

Dyson We Recycle
Reply Paid 83215
Dyson Service Centre
8-10 Mangrove Lane
Taren Point, NSW 2229

- Keep the used batteries away from children as these can still harm children if swallowed.
- Dispose of the exhausted filter unit(s) in accordance with local ordinances or regulations.
- The battery should be removed from the machine before disposal.

DYSON CUSTOMER CARE

THANK YOU FOR CHOOSING TO BUY A DYSON MACHINE

After registering your two-year Dyson guarantee, your Dyson machine will be covered for parts and labour for two years from the date of purchase, subject to the terms of the guarantee. If you have any questions about your Dyson machine, call the Dyson Helpline with your serial number and details of where and when you bought the machine. Most questions can be solved over the phone by one of our trained Dyson Helpline staff.

Your serial number can be found on your rating plate which is on the base of your machine.

- If your Dyson machine needs a service, call the Dyson Helpline so we can discuss the available options.

DYSON 2-YEAR GUARANTEE

TERMS AND CONDITIONS OF THE DYSON 2-YEAR GUARANTEE

AUSTRALIAN CONSUMER LAW

In addition to your rights under the Dyson guarantee, we also provide the following statement as required by the Australian Consumer Law: In Australia, your Dyson machine comes with statutory guarantees that cannot be excluded under the Australian Consumer Law. You are entitled to a replacement or refund for a major failure and for compensation for any other reasonably foreseeable loss or damage. You are also entitled to have your Dyson machine repaired or replaced if it fails to be of acceptable quality and the failure does not amount to a major failure.

NEW ZEALAND CONSUMER LAW

Under the New Zealand Consumer Guarantees Act 1993, if the product is not of acceptable quality but that defect is not substantial, Dyson may choose whether to repair or replace the product. If a repair will be difficult, Dyson may instead provide you with a refund. If a product's defect is substantial or cannot be fixed, you can ask for either a refund, replacement product, or compensation for any reduction in that product's value. You are also entitled to compensation for any other reasonably foreseeable loss caused by that substantial defect.

WHAT IS COVERED

- The repair or replacement of your Dyson machine (at Dyson's discretion) if it is found to be defective due to faulty materials, workmanship or function within two years of purchase (if any part is no longer available or out of manufacture, Dyson will replace it with a functional replacement part).
- This Dyson guarantee will only be valid if the machine is used in the country in which it was sold.

WHAT IS NOT COVERED

Under your Dyson guarantee, Dyson shall not be liable for costs of repair or replacement of a product incurred as a result of:

- Damage caused by not carrying out the recommended machine maintenance.
- Accidental damage, faults caused by negligent use or care, misuse, neglect, careless operation or handling of the Dyson machine which is not in accordance with your Dyson User manual.
- Use of the Dyson machine for anything other than normal domestic purposes in the country of purchase.
- Use of parts not assembled or installed in accordance with the instructions of Dyson.
- Use of parts and accessories which are not genuine Dyson components.
- Faulty installation (except where installed by Dyson).
- Repairs or alterations carried out by parties other than Dyson or its authorised agents.
- Blockages – refer to the illustrations and the section 'Clearing blockages' in your Dyson User manual for details on how to look for and clear blockages.
- Normal wear and tear (e.g. fuse etc.).
- Reduction in battery discharge time due to battery age or use (where applicable).
- Whether or not the Dyson guarantee applies, you may have rights and remedies available to you under Australian or New Zealand Consumer Law.

OTHER TERMS RELATING TO THE DYSON GUARANTEE

- The Dyson guarantee becomes effective from the date of purchase.
- All work will be carried out by Dyson Appliances (Aust.) Pty Limited, Dyson New Zealand Limited (NZ) or their authorised agents.
- Any parts replaced by Dyson or its service agents will become the property of Dyson Appliances (Aust.) Pty Limited or Dyson New Zealand Limited (NZ).
- You must provide proof of purchase for your Dyson machine in order to make a claim under the Dyson guarantee.
- Under the Dyson guarantee, the repair, replacement and any associated delivery charges (both to and from Dyson) will be at no cost to you.
- Whether or not the Dyson guarantee applies, you may have rights and remedies available to you under Australian or New Zealand Consumer Law.

IMPORTANT DATA PROTECTION INFORMATION

When registering your Dyson machine:

- You will need to provide us with basic contact information to register your machine and enable us to support your Dyson guarantee.
- When you register, you will have the opportunity to choose whether you would like to receive communications from us. If you opt-in to communications from Dyson, we will send you details of special offers and news of our latest innovations.
- We never sell your information to third parties and only use information that you share with us as defined by our privacy policies which are available on our website privacy.dyson.com.



Dyson customer care

If you have a question about your Dyson machine, call the Dyson Helpline with your serial number and details of where and when you bought the machine, or contact us via the Dyson website.

AU

www.dyson.com.au

1800 239 766

aucustomercare@dyson.com

Dyson Appliances (Aust.) Pty Ltd, 8 – 10 Mangrove Lane,
Taren Point NSW 2229, Australia

NZ

www.dyson.co.nz

0800 397 667

help@dyson.co.nz

Dyson New Zealand Limited, Unit 6, 99 Carbine Road,
Mt Wellington, Auckland 1060 New Zealand



Register your Dyson machine online



Australia
dyson.com.au/register

New Zealand
dyson.co.nz/register

Why register?



Expert advice

Free phone and live chat support.



Exclusive owner benefits

Priority access to previews of new Dyson technology, events and offers.

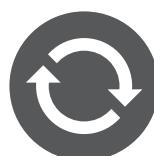

Hassle-free replacement

The Dyson Guarantee includes replacement of your machine when it can't be repaired. Fast.



Free Dyson parts and labour

The Dyson Guarantee covers replacement parts or repairs if something goes wrong.



'How to' Videos

To help you get the most from your machine. Quick and easy.



Helpful tips

Tailored reminders that will keep your machine working at its best, for longer.