EC935X

La Specialista

PRESTIGIO

MACCHINA DA CAFFÈ

COFFEE MAKER

MACHINE À CAFÉ

KAFFEEMASCHINE

KOFFIEZETAPPARAAT

CAFETERA

MÁQUINA DE CAFÉ

ΜΗΧΑΝΗ ΓΙΑ ΚΑΦΕ

KAFFEMASKIN

KAFFEMASKIN

KAFFEMASKINE

KAHVINKEITIN

ΚΟΦΕΜΑШИΝΑ

ΚΟΦΕ ЖАСАҒЫШ

KÁVÉFŐZŐGÉP

KÁVOVAR

KÁVOVAR

EKSPRES DO KAWY

APARAT DE PREPARAT CAFEA

ماكينة قهوة



De'Longhi

IT

pag. 6

EN

page 19

FR

pag. 32

DE

S. 45

NL

pag. 60

ES

pág. 74

PT

pág. 87

EL

σελ 101

NO

sid. 116

SV

sid. 129

DA

sid. 142

FI

siv. 155

RU

стр.168

KZ

181-бет

HU

old. 217

CS

str. 231

SK

str. 245

PL

str. 259

RO

pag. 273

AR

2

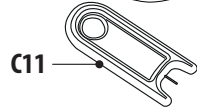
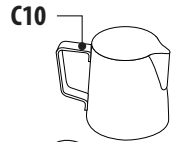
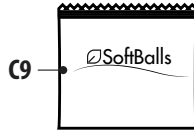
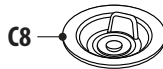
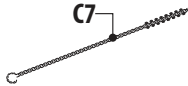
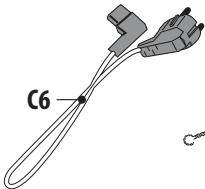
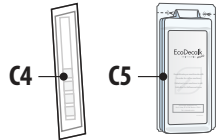
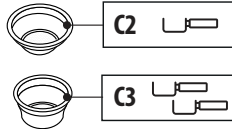
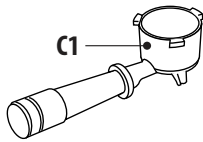
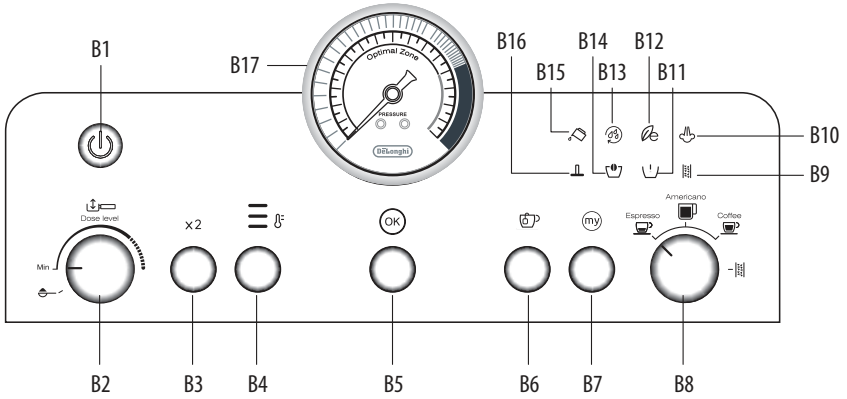

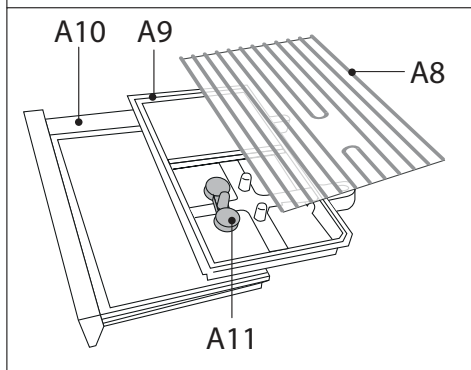
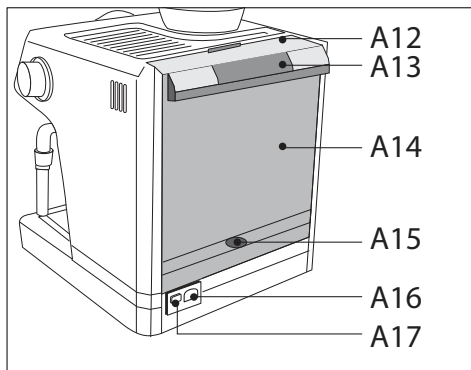
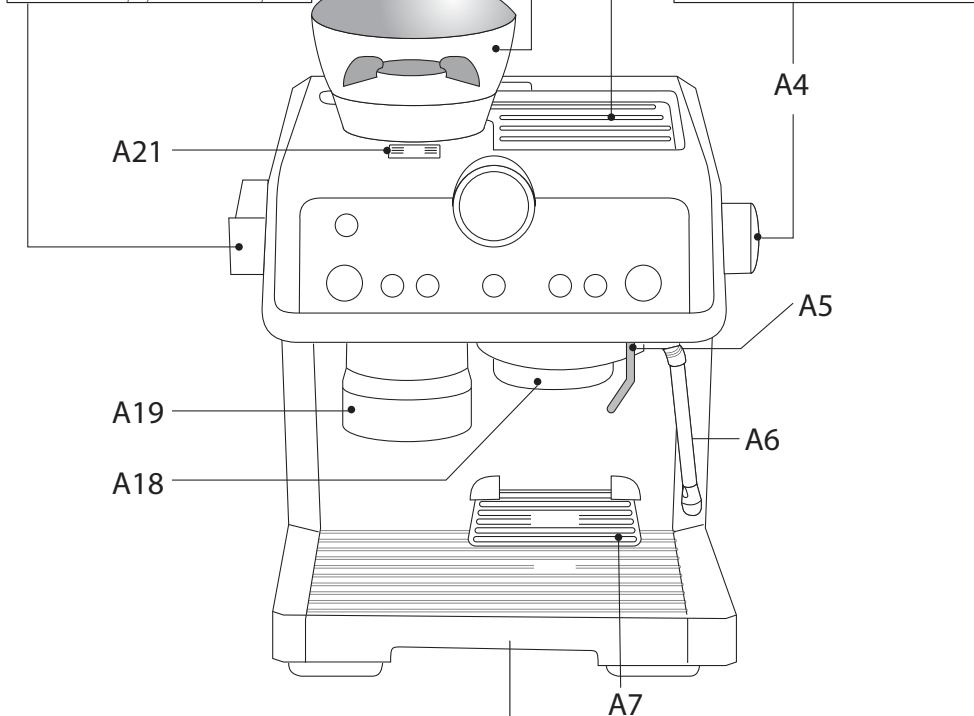
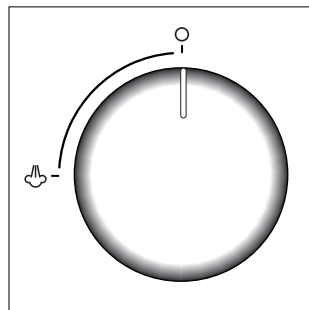
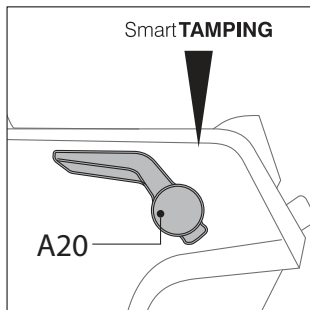

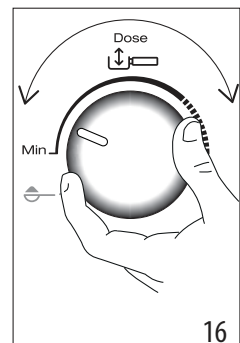
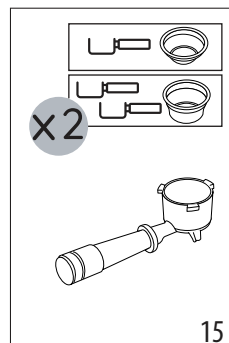
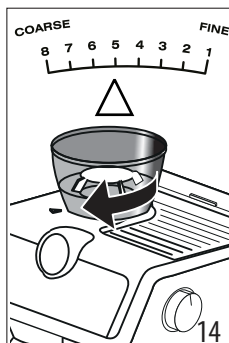
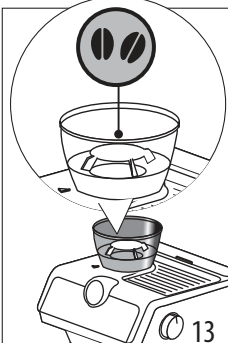
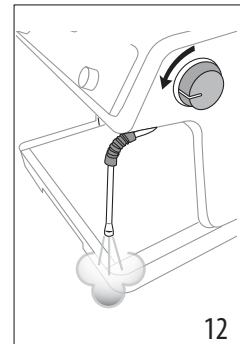
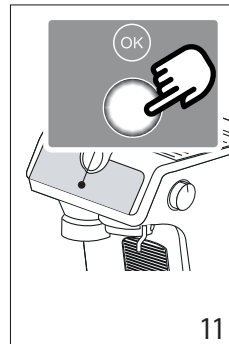
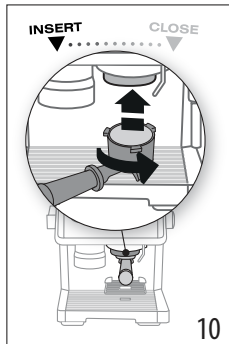
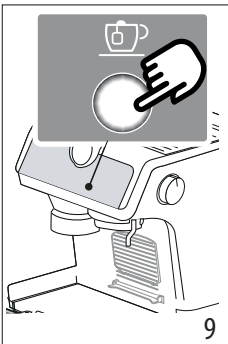
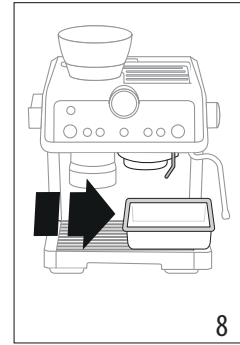
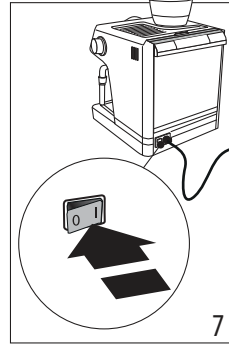
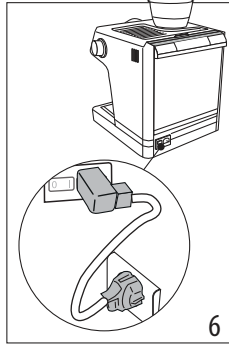
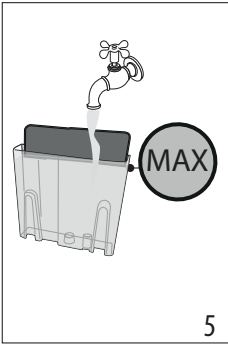
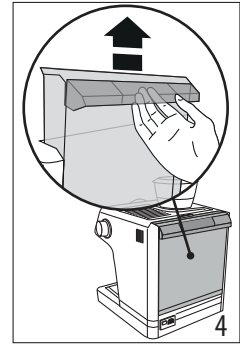
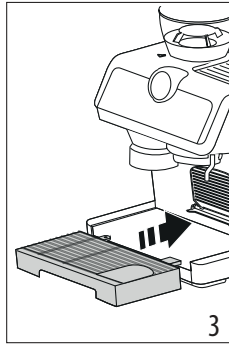
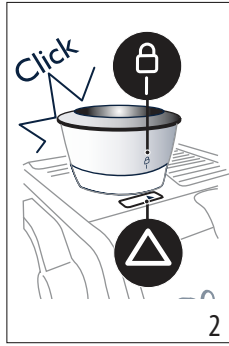
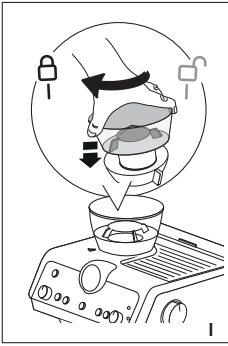

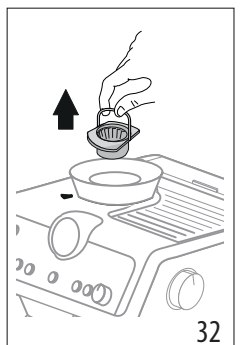
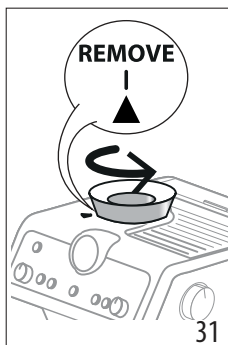
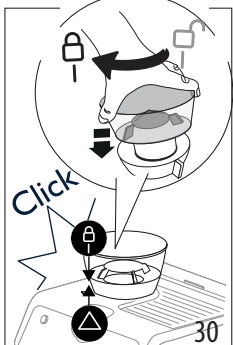
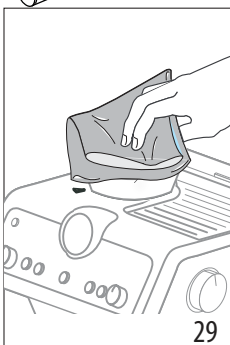
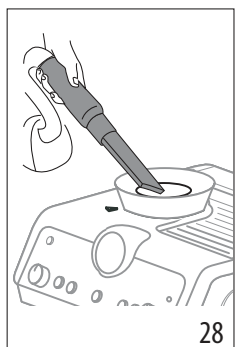
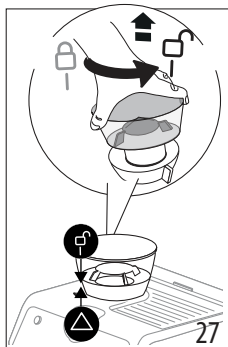
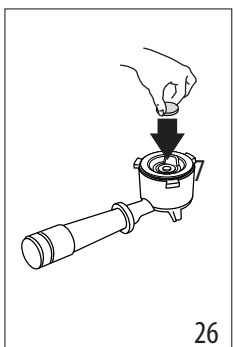
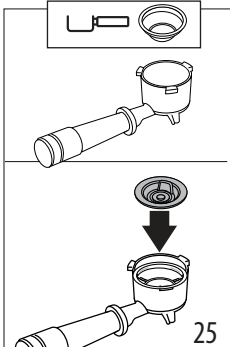
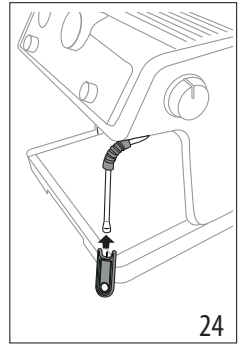
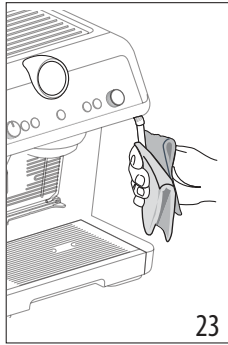
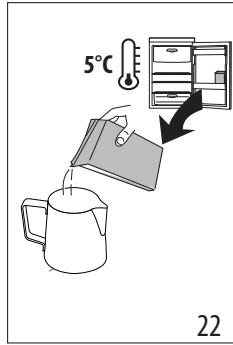
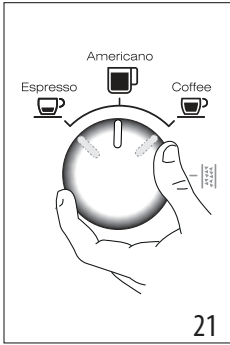
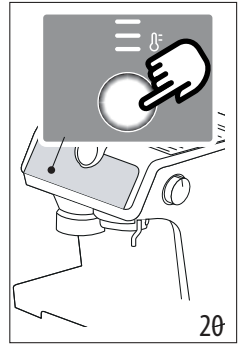
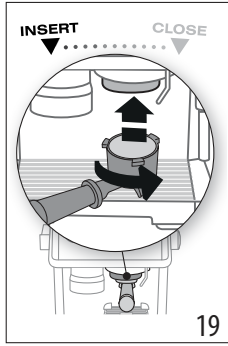
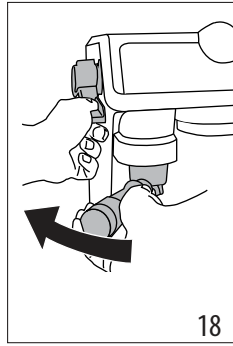
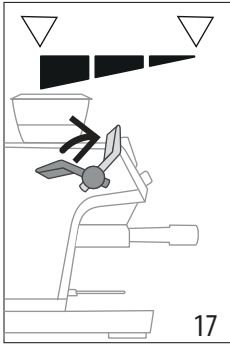

Prima di utilizzare l'apparecchio leggere sempre il fascicolo delle avvertenze di sicurezza.

1. DESCRIZIONE

1.1 Descrizione dell'apparecchio - A

- A1. Coperchio contenitore chicchi
- A2. Contenitore chicchi
- A3. Poggiatazze
- A4. Manopola vapore
- A5. Erogatore acqua calda
- A6. Tubo erogatore vapore
- A7. Griglia poggiatezze per espresso
- A8. Griglia poggiatezze per bicchieri o mug
- A9. Griglia vaschetta
- A10. Vaschetta raccogliocce
- A11. Indicatore di livello acqua nella vaschetta raccogliocce
- A12. Coperchio serbatoio acqua
- A13. Maniglia estrazione serbatoio acqua
- A14. Serbatoio acqua
- A15. Sede filtro addolcitore
- A16. Sede connettore cavo alimentazione
- A17. Interruttore generale (ON/OFF)
- A18. Erogatore caffè
- A19. Uscita macinacaffè (Tamping station)
- A20. Leva pressino
- A21. Sportellino per accedere allo scivolo del macinacaffè

1.2 Descrizione pannello di controllo - B

- B1. Tasto ON/Standby
- B2. Manopola regolazione quantità caffè macinato
- B3. Tasto "X2": per utilizzare il filtro 2 caffè
- B4. Tasto "temperatura caffè"
- B5. Tasto "OK": per erogare la bevanda/per confermare
- B6. Tasto "erogazione acqua calda"
- B7. Tasto "My": per personalizzare la lunghezza delle bevande
- B8. Manopola selezione funzioni
 - Espresso
 - Americano
 - Coffee
 - Decalcificazione
- B9. Spia "decalcificazione"
- B10. Spia "pronto vapore"
- B11. Spia "mancanza contenitore chicchi"
- B12. Spia "risparmio energetico"
- B13. Spia "Pulizia" (vedi "8.1 Cleaning of the coffee outlet")
- B14. Spia "contenitore chicchi vuoto"
- B15. Spia "mancanza acqua"
- B16. Spia "pressatura"
- B17. Manometro

1.3 Descrizione degli accessori - C

- C1. Coppetta portafiltro
- C2. Filtro 1 tazza
- C3. Filtro 2 tazze
- C4. Striscia reattiva "Total Hardness Test"
- C5. Decalcificante
- C6. Cavo alimentazione removibile
- C7. Scovolino
- C8. Accessorio pulizia erogatore caffè
- C9. Softballs
- C10. Bricco latte
- C11. Ago di pulizia per lancia vapore

1.4 Accessori pulizia non inclusi, raccomandati dal costruttore

Per maggiori informazioni, visita Delonghi.com.



Pastiglie pulizia

(Vedi "8.1 Pulizia dell'erogatore caffè")

EcoMultiClean Detergente

EAN: 8004399333307

2. PREPARAZIONE DELL'APPARECCHIO

Lavare con acqua tiepida e detersivo per piatti tutti gli accessori, quindi procedere come segue:

1. Inserire il contenitore chicchi (A2) nel macinacaffè (fig. 1). Il contenitore è inserito correttamente quando la freccia ▲ è allineata al simbolo ☐ e si sente un "click" (fig. 2).
2. Inserire il vassoio raccogliocce (A10) completo di griglia poggiatezze (A8) e griglia vaschetta (A9) (fig. 3);
3. Estrarre il serbatoio acqua (A14) (fig. 4) e riempirlo con acqua fresca e pulita facendo attenzione a non superare la scritta MAX (fig. 5).
4. Quindi reinserire il serbatoio.

Attenzione: Non mettere mai in funzione l'apparecchio senza l'acqua nel serbatoio senza serbatoio.

Nota bene: Si consiglia di personalizzare al più presto la durezza dell'acqua seguendo la procedura descritta nel capitolo "7. Menù impostazioni".

3. PRIMA MESSA IN FUNZIONE DELL'APPARECCHIO

1. Inserire il connettore del cavo alimentazione (C6) nell'apposita sede (A16) sul retro dell'apparecchio (fig. 6); quindi inserire la spina nella presa. Assicurarsi che l'interruttore generale (A17), posto sul retro dell'apparecchio sia premuto in posizione I (fig. 7);
2. Posizionare sotto l'erogatore acqua calda (in corrispondenza dell'erogatore caffè (A18)) un contenitore con capienza minima di 100 ml (fig. 8);
3. Premere il tasto (B6) in corrispondenza della spia ☐ (fig. 9): l'erogazione inizia e si interrompe automaticamente. Svuotare il contenitore.

Prima di iniziare a utilizzare la macchina, è necessario risciacquare i circuiti interni della macchina. Procedere come segue:

4. Agganciare la coppetta portafiltro (C1) completa di filtro alla macchina: per un aggancio corretto, allineare il manico della coppetta portafiltro a "INSERT" (fig. 10) e ruotare l'impugnatura verso destra, fino ad allinearla alla posizione "CLOSE";
5. Mettere un contenitore sotto la coppetta portafiltro e al tubo erogatore vapore (A6);
6. Premere il tasto OK (B5) (fig. 11): l'erogazione comincia;
7. Finita l'erogazione, ruotare la manopola vapore (A4) (fig. 12) ed erogare vapore per alcuni secondi in modo da risciacquare il circuito vapore: per un'erogazione ottimale di vapore, si consiglia di ripetere quest'operazione per 3 o 4 volte. Questo permette di eliminare l'acqua nel tubo prima di erogare vapore.

L'apparecchio è quindi pronto all'uso.

Nota bene: il risciacquo dei circuiti interni è consigliato anche in caso di prolungato inutilizzo dell'apparecchio.

Al primo utilizzo è necessario fare 4-5 caffè prima che la macchina cominci a dare un risultato soddisfacente: dedicare particolare attenzione alla dose caffè macinata nel filtro ((C2) o (C3)) (vedi istruzioni al paragrafo "4.1 Fase 1 - Macinatura (grinding)"). Procedere come indicato al capitolo "La dose perfetta".

4. PREPARARE IL CAFFÈ

4.1 Fase 1 - Macinatura (grinding)

1. Versare i chicchi nel contenitore (A2) (fig. 13). È consigliabile versare solo i chicchi necessari alla preparazione: in questo modo si utilizzerà sempre caffè fresco;
2. Selezionare il grado di macinatura (fig. 14). L'impostazione di fabbrica è 5 (macinatura media). Se il risultato non fosse soddisfacente, regolare il livello in base al gusto personale e al tipo di caffè (la regolazione va effettuata durante il funzionamento del macinacaffè).

Nota bene: Il grado di macinatura tra 3 e 6 è consigliato per la maggior parte dei caffè. Il risultato della macinatura con selezione su 1 o 2, è molto fine, da utilizzare solo con caffè molto particolare (tostato leggero).

3. Inserire uno dei filtri caffè (C2) o (C3) nel portafiltro (C1) (fig. 15). Se si utilizza il filtro per 2 tazze, premere il tasto X2 (B3): con questa selezione raddoppia anche la quantità erogata di espresso.
4. Regolare la manopola quantità (B2) partendo dalla posizione minima (fig. 16).

Fare riferimento al paragrafo "Regolare la quantità di caffè macinato nel filtro" per ulteriori indicazioni.

5. Agganciare il portafiltro all'uscita macinacaffè (A19) allineandolo alla scritta INSERT: quindi ruotare verso destra la coppetta. La macinatura inizia quando la coppetta raggiunge la posizione CLOSE e si interrompe automaticamente.

Regolare la quantità di caffè macinato nel filtro

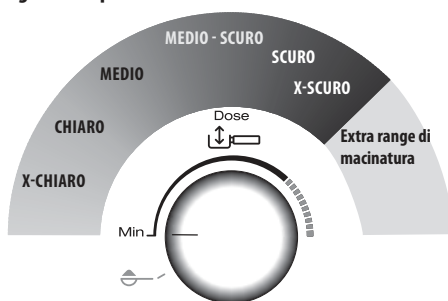

Ogni varietà di chicco dà un risultato diverso durante la macinatura e per questo all'inizio la regolazione della dose richiede estrema cura.

Questa illustrazione dà delle indicazioni su come regolare la dose, basate sul colore di tostatura: sono da considerarsi un punto di partenza, ma possono variare in base alla composizione dei chicchi caffè.

1. Impostare la dose dalla posizione minima.
2. Facendo riferimento al colore di tostatura del vostro caffè, ruotare lentamente la manopola.

4.2 Fase 2 - Pressatura (tamping)

1. Dopo la macinatura, abbassare la leva pressatura (A20) fino a fine corsa (non rimuovere il portafiltro) (fig. 17). Per un risultato perfetto, ripetere 2 volte.
2. Mantenere abbassata la leva fino a fine corsa durante la rimozione del portafiltro (fig. 18). Poi riportare la leva nella posizione iniziale.
3. Una volta verificato che la dose caffè sia corretta (vedi "La dose perfetta"), agganciare il portafiltro all'erogatore caffè (A18) (fig. 19).

Nota bene: Se dopo la pressatura rimane del caffè residuo lungo i bordi del filtro, questo non pregiudica assolutamente la qualità dell'estrazione e quindi il risultato finale.

La "dose perfetta"

- I filtri caffè, hanno un riferimento interno per identificare la dose perfetta.



Marchatura a laser

Marchatura in rilievo

- Filtri con marcatura a laser: la dose perfetta corrisponde alla linea superiore della marcatura;
- Filtri con marcatura in rilievo: la dose perfetta corrisponde alla linea in rilievo;

- Assicurarsi che il caffè sia a livello dopo la pressatura. Potrebbe essere necessario regolare più volte la manopola (B2) prima di arrivare alla dose perfetta.
- Se il caffè è sovra- o sotto-estratto e la dose è all'interno della dose perfetta, regolare il grado di macinatura più fine o più grossolana (vedi "4.1 Fase 1 - Macinatura (grinding)"). Se il caffè è sovra- estratto (erogazione troppo lenta) la macinatura dovrà essere più grossolana. Se il caffè è sotto-estratto (erogazione troppo veloce) la macinatura dovrà essere più fine.
- **Il barista consiglia:** Estrarre il portafiltro mentre la leva del pressino (A20) è abbassata per ottenere una perfetta finitura della dose di caffè.
- **Se si utilizza caffè pre-macinato:**
 - versare il caffè premacinato nel filtro;
 - ruotare la manopola su ;
 - agganciare il portafiltro all'uscita macinacaffè;
 - abbassare la leva pressatura.







4.3 Fase 3 - Erogazione (brewing)

1. Selezionare la temperatura (fig. 20) (vedi "La temperatura per preparare il caffè").
2. Selezionare la bevanda desiderata (fig. 21).
3. Premere OK (B5) per iniziare l'erogazione (fig. 11) (pre-infusione ed infusione). L'erogazione caffè si interrompe automaticamente.

La temperatura per preparare il caffè

La temperatura dell'acqua è controllata durante l'intero processo di preparazione per garantirne la stabilità in fase di estrazione. La Specialista Prestigio offre 3 temperatura di infusione* che corrispondono ad un range tra i 92°C e i 96°C.

A seconda della varietà e della tostatura dei chicchi, si consiglia una temperatura diversa: i chicchi di Robusta richiedono una temperatura bassa; i chicchi di Arabica una temperatura alta. Lo stesso vale per i chicchi con tostatura scura o per i chicchi appena tostati.

Livello di temperatura	Spia corrispondente	Livello di tostatura
MIN	 	Scuro
MED	 	Medio-scuro
MAX	 	Chiaro - medio

- * Questa temperatura fa riferimento all'acqua nel thermo-block. È quindi diversa dalla temperatura della bevanda in tazza o dalla temperatura misurata quando la bevanda esce dagli erogatori del portafiltro.

5. PREPARAZIONE BEVANDE LATTE

5.1 Schiumare il latte

1. Versare nel bricco (C10) la quantità di latte che si vuole scaldare/schiumare, tenendo conto che il volume del latte aumenterà di 2 o 3 volte (fig. 22). Per ottenere una schiuma più densa e omogenea, è consigliabile utilizzare latte vaccino intero ed a temperatura di frigorifero (circa 5°C).

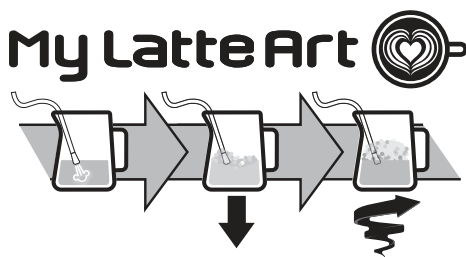

2. Per schiumare il latte, appoggiare il tubo erogatore vapore (A6) sulla superficie del latte: così facendo l'aria si mescola al latte e al vapore.
3. Mantenere l'erogatore vapore sulla superficie, prestando attenzione a non catturare troppa aria creando bolle troppo grosse.
4. Immergere l'erogatore vapore sotto la superficie del latte: in questo modo si crea un vortice. Una volta raggiunta la temperatura desiderata, richiudere la manopola vapore e attendere che l'erogazione vapore si interrompa completamente prima di rimuovere il bricco del latte.

Il barista consiglia:





- **Il latte fresco è migliore.** Utilizzare sempre latte fresco a temperatura di frigorifero.
- Per un risultato migliore, si consiglia di riporre sempre il brico del latte in frigorifero.
- Il latte intero assicura ottimi risultati. Il risultato e la texture della schiuma variano a seconda del latte vaccino o delle bevande vegetali utilizzate.
- Dopo aver schiumato il latte, eliminare le bolle roteando leggermente il bricco del latte.

Pulizia dell'erogatore vapore:

1. Dopo ogni uso, rimuovere con un panno i residui di latte dall'erogatore vapore (fig. 23). Per una pulizia profonda, è consigliabile utilizzare Eco MultiClean: assicura l'igiene rimuovendo proteine e grassi del latte e può essere utilizzato per pulire l'intera macchina.

- Erogare vapore per alcuni secondi per pulire bene l'erogatore (fig. 12).
- Attendere che l'erogatore si raffreddi: per mantenere l'efficienza dell'erogatore nel tempo, utilizzare l'ago di pulizia (C11) per mantenere liberi i 3 fori (fig. 24).







6. PERSONALIZZARE LA LUNGHEZZA DELLE BEVANDE CAFFÈ CON IL TASTO (B7)

- Preparare la macchina per erogare 1 o 2 tazze della bevanda caffè che si desidera erogare, fino ad agganciare il portafiltro (C1) completo di filtro (C2) o (C3) e caffè macinato.
- Ruotare la manopola (B8) per selezionare la bevanda da programmare.
- Premere il tasto : la spia corrispondente al tasto  lampeggia.
- Premere il tasto OK per iniziare l'erogazione. Le spie corrispondenti ai tasti OK e  lampeggiano.
- Una volta raggiunta la quantità desiderata, premere OK. Se la bevanda prevede l'erogazione di un altro ingrediente, comincia l'erogazione di quest'ultimo: una volta raggiunta la quantità desiderata, premere OK.
- Premere il tasto  per salvare. L'apparecchio è pronto per un nuovo utilizzo e la spia  rimane accesa.

Se non si desidera salvare la programmazione, premere qualsiasi altro tasto.

Nota bene:

- Si possono programmare le bevande con caffè, ma non l'erogazione di vapore e acqua calda.
- La programmazione modifica le quantità delle bevande, ma non del caffè macinato.
- Le bevande "X2" possono essere programmate separatamente.
- Per ritornare alle impostazioni di fabbrica, mantenere premuto il tasto  fino allo spegnimento. La bevanda selezionata torna alla quantità di fabbrica.**

Ricetta caffè	Quantità di fabbrica	Quantità programmabile
 Espresso	35 ml	da 25 a 90 ml
 Espresso X2	70 ml	da 50 a 180 ml
 Coffee	80 ml	da 50 a 120 ml
 Coffee X2	160 ml	da 120 a 240 ml
 Americano	120 ml	<ul style="list-style-type: none"> espresso: da 25 a 60 ml acqua: da 25a 120 ml
 Americano X2	240 ml	<ul style="list-style-type: none"> espresso: da 50 a 120 ml acqua: da 50 a 240 ml

7. MENÙ IMPOSTAZIONI

1. Entrare nel menù:

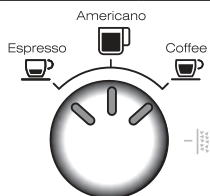

Premere contemporaneamente per 5 secondi	x2	
--	----	--

2. Impostazioni con selezione da manopola (B8)



Impostazione corrispondente	Ruotare su	Regolazioni
Regolazione extra della macinatura		x2 → Range 1
		 → Range 2
Durezza acqua		x2 → dolce
		 → media
		 → dura/molto dura
Auto-spegnimento		x2 → 9 minuti
		 → 1,5 ore
		 → 3 ore

3. Impostazione con selezione da tasto:

Risparmio energetico	 → Attivo
	 → Spento
Valori di fabbrica	Mantenere premuto per almeno 5 secondi il tasto  , finchè la spia rimane accesa fissa

4. Salvare le nuove impostazioni premendo ON/Standby (B1)



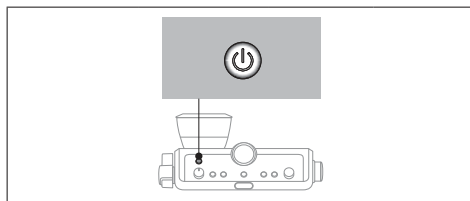











8. PULIZIA DELL'APPARECCHIO

Attenzione!

- Per la pulizia della macchina non usare solventi, detergenti abrasivi o alcool.
- Non utilizzare oggetti metallici per togliere le incrostazioni o i depositi di caffè, perché potrebbero graffiare le superfici in metallo o in plastica.
- Per periodi di inutilizzo superiori alla settimana è consigliato, prima di utilizzare la macchina, di procedere ad un risciacquo.

Pericolo!



- Durante la pulizia, non immergere mai la macchina nell'acqua: è un apparecchio elettrico.
- Prima di qualsiasi operazione di pulizia delle parti esterne dell'apparecchio, spegnere la macchina, staccare la spina dalla presa di corrente e lasciar raffreddare la macchina.

					
	×	✓	✓	×	×
	✓	×	×	✓	✓
	×	×	×	✓	✓
	×	×	×	✓	✓
	×	×	✓	✓	×
	×	×	×	✓	✓

8.1 Pulizia dell'erogatore caffè

Quando la spia  si accende (arancione) (B13), è necessario procedere alla pulizia del circuito caffè. Per eseguire il ciclo di pu-



lizia, acquistare le pastiglie per la pulizia per macchine da caffè. Per maggiori informazioni, visitare www.Delonghi.com.

1. Inserire il filtro 1 tazza (C2) nel portafiltro (C1) (fig. 25).
2. Inserire nel filtro l'accessorio pulizia (C8) (fig. 25) e premerlo a fondo.
3. Mettere la pastiglia per la pulizia sull'accessorio (fig. 26).
4. Attaccare il portafiltro all'erogatore caffè (A18).
5. Riempire il serbatoio acqua (A14). Assicurarsi che la vaschetta raccogliacqua (A10) sia vuota.
6. Mantenere premuto il tasto  (B6), finché si accende la spia  (B13). Dopo alcuni minuti, la pulizia si interrompe automaticamente.
7. Rimuovere il portafiltro e l'accessorio pulizia.
8. Lavare il portafiltro ed il filtro sotto l'acqua corrente.
9. Reinserrire il portafiltro e procedere con un risciacquo premendo il tasto  : si consiglia di mettere un contenitore sotto il portafiltro.
10. Rimuovere e svuotare la vaschetta raccogliacqua.

Nota bene:

Questo ciclo di pulizia può essere avviato in ogni momento premendo il tasto  per alcuni secondi. Per cancellare l'operazione, premere il pulsante per 10 secondi.

8.2 Pulire l'alloggiamento del contenitore chicchi

1. Assicurarsi che il contenitore chicchi (A2) sia vuoto. Eventualmente procedere con alcune macinature a vuoto per svuotarlo.
2. Sganciare il contenitore ruotandolo in senso antiorario ed estrarlo dalla macchina (fig. 27)
3. Aspirare i residui di caffè (fig. 28).
4. Pulire con un panno umido la sede del contenitore chicchi e asciugare (fig. 29);
5. Riposizionare il contenitore inserendolo nel macinacaffè. Il contenitore è inserito correttamente quando la freccia  è allineata al simbolo  e si sente un "click" (fig.30).

8.3 Pulizia delle macine

Quando si pulisce il contenitore chicchi (A2), pulire la sede del contenitore e la macina superiore con un panno umido. Rivolgersi ad un centro assistenza per rimuovere e sostituire le macine.

È possibile rimuovere la macina qualora il macinacaffè fosse bloccato da un corpo estraneo. Se questo dovesse accadere, rimuovere il contenitore chicchi e procedere come segue:

1. Agganciare la coppetta portafiltro (C1) e fare una macinatura "a vuoto" per liberare il condotto caffè.
2. Spegner l'apparecchio.
3. Ruotare in senso antiorario il regolatore di macinatura fino a fine corsa, in posizione "REMOVE" (fig. 31).
4. Estrarre la parte superiore della macina, afferrandola dall'apposita maniglia (fig.32).

5. Pulire la macina con un pennello (fig. 33) e aspirare i residui di caffè con un aspirapolvere (fig. 28).

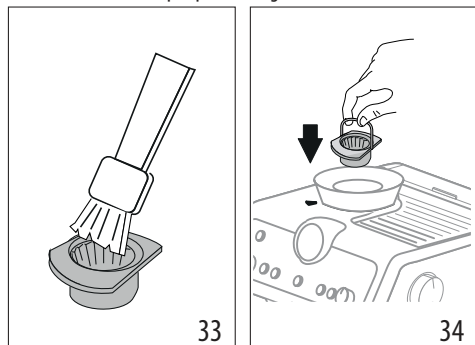

6. Inserire la macina nella sua sede (fig. 34);
7. Ruotare il regolatore selezionando il grado di macinatura desiderato (fig. 14);

Verificare che la macina sia ben inserita, tirandola per la maniglia: la macina è correttamente inserita se non si muove.

8.4 Sostituzione delle macine

Quando la quantità di caffè macinato si riduce ancora, rivolgersi ad un centro assistenza per sostituire le macine: poi regolare di nuovo il macinacaffè entrando nel menù impostazioni ("7. Menù impostazioni") e selezionando il primo range della regolazione extra della macinatura. Quindi, ruotare la manopola regolazione quantità (B2) in posizione MIN e regolare la dose come ad il primo utilizzo (vedi "La dose perfetta").

8.5 Pulizia della "Smart tamping station"

1. Pulire la zona di aggancio con un pennello (fig. 35).
2. Tirare la leva (A20) fino a fine corsa e pulire con un pennello il pressino (fig. 36), quindi rilasciare la leva.
3. Utilizzando lo scovolino (C7), pulire lo scivolo caffè (fig. 37).

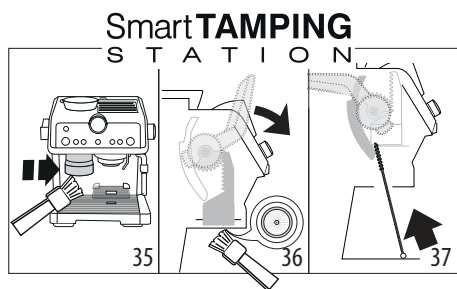





9. DUREZZA ACQUA

La spia  (B9) decalcificazione si accende dopo un periodo di funzionamento predeterminato che dipende dalla durezza dell'acqua. È possibile programmare la macchina in base alla

reale durezza dell'acqua in utenza nelle varie regioni, rendendo così meno frequente l'operazione di decalcificazione.

1. Togliere dalla sua confezione la striscia reattiva in dotazione "TOTAL HARDNESS TEST" (C4).
2. Immergere completamente la striscia in un bicchiere d'acqua per circa un secondo.
3. Estrarre la striscia dall'acqua e scuoterla leggermente. Impostare l'apparecchio, come indicato nel capitolo "7. Menù impostazioni".

Risultato Test Durezza Acqua	Tasto	Livello
	×2	1 acqua dolce
	 Ⓕ	2 acqua media
	OK	3 acqua dura o molto dura
		

4. Impostare l'apparecchio, come indicato nel capitolo "7. Menù impostazioni".

10. COME UTILIZZARE SOFTBALLS

Softballs (C9) è un sistema innovativo che allunga la vita della macchina, senza alterare le qualità dell'acqua, garantendo l'erogazione di un caffè cremoso e aromatico. Per ottimizzare l'efficacia, lasciare Softballs nell'acqua per l'intera notte precedente all'uso.

1. Estrarre il pacchetto di Softballs dall'imballo (fig. 38).

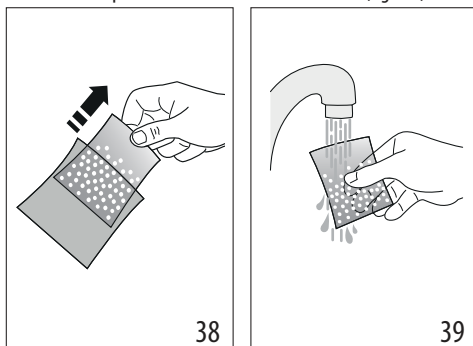

2. Risciacquare con acqua corrente il pacchetto di Softballs (fig. 39).
3. Immergere il sacchetto nel serbatoio acqua (A14) (fig. 40).

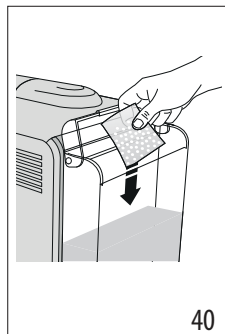

4. Sostituire il sacchetto di Softballs ogni 3 mesi (fig. 41).

11. DECALCIFICAZIONE

Attenzione!

- Prima dell'uso, leggere le istruzioni e l'etichettatura del decalcificante (C5), riportate sulla confezione del decalcificante stesso.
- Si raccomanda di utilizzare esclusivamente decalcificanti De'Longhi. L'utilizzo di decalcificanti non idonei, come pure la decalcificazione non regolarmente eseguita, può comportare l'insorgenza di difetti non coperti dalla garanzia del produttore.
- Il decalcificante può danneggiare le superfici delicate. Se il prodotto viene rovesciato accidentalmente, asciugare immediatamente.

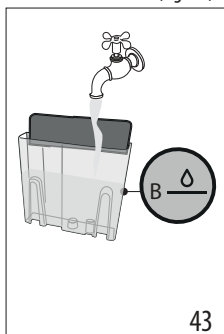
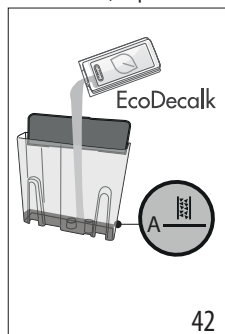

Per effettuare la decalcificazione	
Decalcificante	Decalcificante De'Longhi
Contenitore	Capacità 2 litri
Tempo	~40min

1. (SE PRESENTI, TOGLIERE IL FILTRO ADDOLCITORE E SOFTBALLS). Versare nel serbatoio acqua (A14) il decalcificante fino al livello  **A** (corrispondente a una confezione da 100ml) impresso sul lato interno del serbatoio (fig. 42).

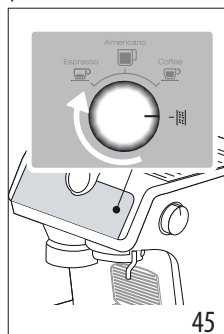
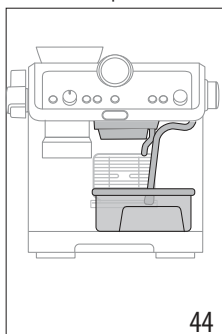

2. Aggiungere acqua fino a raggiungere il livello  **B** (fig. 43). Reinserire quindi il serbatoio acqua in macchina.



3. Assicurarsi che il portafiltro (C1) non sia agganciato e posizionare un recipiente sotto gli erogatori caffè, acqua calda e sotto l'erogatore vapore (A6) (fig. 44).
4. Ruotare la manopola (B8) su  (fig. 45): la spia OK si accende di colore arancio e la spia  lampeggia.
5. Premere il tasto OK: la spia OK lampeggia.
6. Il programma di decalcificazione si avvia ed il liquido decalcificante esce dagli erogatori. Il programma di decalcificazione esegue automaticamente tutta una serie di risciacqui ad intervalli, per rimuovere i residui di calcare dall'interno della macchina da caffè fino a svuotare il serbatoio. L'erogazione si interrompe e la spia OK diventa bianca. È quindi necessario procedere con il ciclo di risciacquo:
7. Svuotare il recipiente utilizzato per la raccolta del liquido decalcificante e riporlo sotto gli erogatori.
8. Estrarre il serbatoio acqua, svuotarlo da eventuali residui di soluzione decalcificante, sciacquarlo con acqua corrente e riempirlo con acqua fresca fino al livello MAX (fig. 46). Reinserire quindi il serbatoio nella sua sede.

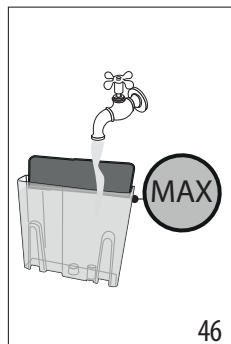









9. Premere il tasto OK: il risciacquo si avvia.
10. Una volta completato il risciacquo, l'erogazione si interrompe e l'apparecchio è pronto all'uso.

11. Svuotare i recipienti di raccolta dell'acqua di risciacquo.
 12. Estrarre e svuotare il vassoio raccogli gocce, quindi reinserirlo.
 13. Estrarre e riempire il serbatoio con acqua fresca, quindi reinserirlo.
- Ora l'apparecchio è pronto all'uso.





Nota bene:









- Il ciclo di decalcificazione può essere avviato in ogni momento (anche se la relativa spia non è ancora accesa).
- Nel caso la decalcificazione sia stata avviata per sbaglio, premere il tasto OK per 10 secondi; il risciacquo non può essere interrotto.

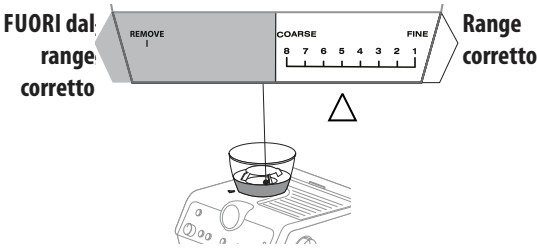

12. SIGNIFICATO DELLE SPIE

SPIE	SIGNIFICATO DELLE SPIE	OPERAZIONE
Tutte le spie lampeggiano brevemente	Accensione dell'apparecchio	Autodiagnosi
 fissa	È la prima accensione della macchina ed è necessario procedere al riempimento del circuito acqua	Procedere come indicato al cap. "3. Prima messa in funzione dell'apparecchio"
 fissa (bianca)	La macchina è pronta per l'erogazione	Preparare la macchina e procedere con la preparazione della bevanda
<ul style="list-style-type: none"> • Spia : indica la temperatura caffè selezionata • Spia : indica che la macchina è pronta ad erogare acqua calda 		
 fissa	La funzione risparmio energetico è attiva	Fare riferimento al cap. "7. Menù impostazioni" se si desidera disattivare la funzione
 fissa	Il contenitore chicchi (A2) è vuoto	Riempire il contenitore chicchi
 lampeggiante	Si vuole procedere con la macinatura, ma il contenitore chicchi (A2) è vuoto	Riempire il contenitore chicchi
 lampeggia brevemente ad intervalli regolari	La manopola (B2) è ruotata sulla posizione di regolazione massima	Quando dopo la macinatura il caffè nel filtro è insufficiente, selezionare un nuovo range di macinatura come indicato nel capitolo "6. Menù settings".
 fissa	L'acqua nel serbatoio (A14) non è sufficiente oppure il serbatoio acqua non è ben inserito	Riempire il serbatoio oppure estrarre e reinserire correttamente il serbatoio



SPIE	SIGNIFICATO DELLE SPIE	OPERAZIONE
 lampeggiante	Si vuole procedere con la preparazione di una bevanda, ma il serbatoio acqua (A14) è vuoto	Riempire il serbatoio acqua
	La macinatura è troppo fine e quindi il caffè fuoriesce troppo lentamente o non esce del tutto	Estrarre la coppetta portafiltro (C1), ripetere le operazioni per fare il caffè tenendo presente le indicazioni del par. "4.1 Fase 1 - Macinatura (grinding)" e "4.2 Fase 2 - Pressatura (tamping)"
	Il filtro caffè (C2) o (C3) è otturato	Risciacquare i filtri sotto l'acqua corrente
	Il serbatoio (A14) è mal inserito e le relative valvole non sono aperte	Premere leggermente il serbatoio in modo da aprirne le valvole
	Calcare all'interno del circuito idraulico	Eseguire la decalcificazione come al cap. "11. Decalcificazione"
 fissa	L'apparecchio è pronto per l'erogazione di vapore	L'apparecchio ha raggiunto la temperatura per erogare vapore. Per procedere con l'erogazione, ruotare la manopola vapore (A4)
 lampeggiante	L'apparecchio è acceso e la funzione risparmio energetico è attiva: la manopola vapore (A4) è in posizione per erogare vapore	La spia lampeggia ad indicare che l'apparecchio si sta preparando per erogare vapore: l'erogazione inizia appena l'apparecchio è in temperatura
	L'apparecchio è pronto per l'erogazione di vapore	L'apparecchio è in temperatura per la preparazione di vapore quando la spia rimane fissa
	L'apparecchio sta erogando vapore	
 fissa	Il contenitore chicchi non è inserito	Inserire correttamente il contenitore chicchi (A2) o verificare che sia correttamente inserito. Il contenitore è inserito correttamente quando la freccia ▲ è allineata al simbolo ☐ e si sente un "click"
→		

SPIE	SIGNIFICATO DELLE SPIE	OPERAZIONE
 lampeggiante	La regolazione del selettore del grado di macinatura non è corretta o è oltre la regolazione massima possibile	Riportare il selettore in una delle posizioni di macinatura (tra 1 e 8), rammentando di: <ul style="list-style-type: none"> Regolare la macinatura mentre il macinacaffè è in funzione Regolare di un livello alla volta e fare almeno 5 macinature tra una regolazione e l'altra
		
 fissa	L'apparecchio richiede la pressatura	È stata appena eseguita la macinatura ed il portafiltro è agganciato al macina caffè
	Il portafiltro è stato sganciato dal macina caffè senza pressare	Sganciare il portafiltro e procedere pressando il caffè come descritto al par. "La "dose perfetta"" "Se si utilizza caffè pre-macinato."
	Il portafiltro è stato sganciato senza concludere la macinatura o la pressatura è stata eseguita troppo presto	Ripetere la macinatura
	Lo scivolo caffè del macinacaffè è intasato	Procedere alla pulizia come indicato al par. "8.5 Pulizia della "Smart tamping station"". Se il problema persiste, accedere allo scivolo aprendo l'apposito sportellino e liberarlo utilizzando lo scovolino
	Le macine sono bloccate da un corpo estraneo	Rimuovere il corpo estraneo e pulire le macine come indicato al par. "8.3 Pulizia delle macine".
 fissa (rossa)	È necessario procedere con la decalcificazione	Eseguire la decalcificazione come illustrato al cap. "11. Decalcificazione"
 lampeggia (rossa) +  lampeggia (arancione)	L'apparecchio sta eseguendo la decalcificazione	Procedere completando l'operazione come descritto al cap. "11. Decalcificazione"
 lampeggia (rossa) +  fissa (bianca)	È necessario procedere con il risciacquo	
 lampeggi (rossa) +  lampeggia (bianca)	L'apparecchio sta eseguendo il risciacquo del ciclo decalcificazione	
→		

SPIE	SIGNIFICATO DELLE SPIE	OPERAZIONE
 fissa (arancione)	È necessario procedere con la pulizia dell'erogatore caffè	Vedi par. "8.1 Pulizia dell'erogatore caffè"
 lampeggiante (arancione)	L'apparecchio sta eseguendo la pulizia dell'erogatore caffè	
Tutte le spie lampeggiano	Allarme generico	Rivolgersi ad un centro assistenza

13. SE QUALCOSA NON FUNZIONA

PROBLEMA	CAUSA	SOLUZIONE
C'è dell'acqua nella vaschetta raccogli-gocce (A10)	Fa parte del normale funzionamento dai circuiti interni della macchina	Svuotare e pulire regolarmente la vaschetta raccogli-gocce
Non esce più il caffè espresso	Mancanza di acqua nel serbatoio (A14)	Riempire il serbatoio
	La spia  (B6) è accesa ad indicare che il circuito caffè o circuito vapore è vuoto	Premere il tasto corrispondente alla spia  per riempire il circuito
	Il filtro (C2) o (C3) è otturato	Risciacquare i filtri sotto l'acqua corrente
	Il serbatoio (A14) è mal inserito e le valvole sul suo fondo non sono aperte	Premere leggermente il serbatoio in modo da aprire le valvole sul suo fondo
	Calcare all'interno del circuito idraulico	Eseguire la decalcificazione come al cap. "11. Decalcificazione"
	Macinatura troppo fine	Estrarre la coppetta portafiltro (C1), ripetere le operazioni per fare il caffè tenendo presente le indicazioni del par. "4.1 Fase 1 - Macinatura (grinding)" e "4.2 Fase 2 - Pressatura (tamping)"
Il portafiltro non si aggancia all'apparecchio	Il caffè macinato non è stato pressato o è in quantità eccessiva	Ripetere la macinatura con delle impostazioni diverse. Ridurre la quantità della dose: verificare che il filtro (C2) o (C3) (1 o 2 tazze) sia corretto rispetto alla dose da macinare (tasto 2x (B3) selezionato o no)
Il caffè espresso gocciola dai bordi del portafiltro (C1) anziché dai fori	Il portafiltro è male inserito	Agganciare il portafiltro correttamente e ruotarlo fino in fondo con forza
	La guarnizione dell'erogatore caffè (A18) ha perso elasticità o è sporca	Sostituire la guarnizione dell'erogatore caffè presso un Centro Assistenza
	Il filtro (C2) o (C3) è otturato	Risciacquare i filtri sotto l'acqua corrente
La crema del caffè è chiara (scende velocemente dal beccuccio)	È necessario rivedere le impostazioni dell'apparecchio	Estrarre la coppetta, ripetere le operazioni per fare il caffè tenendo presente le indicazioni del par. "4.1 Fase 1 - Macinatura (grinding)" e "4.2 Fase 2 - Pressatura (tamping)"
		→

PROBLEMA	CAUSA	SOLUZIONE
La crema del caffè è scura (il caffè scende lentamente dal beccuccio)	È necessario rivedere le impostazioni dell'apparecchio	Estrarre la coppetta portafiltro (C1), ripetere le operazioni per fare il caffè tenendo presente le indicazioni del par. "4.1 Fase 1 - Macinatura (grinding)" e "4.2 Fase 2 - Pressatura (tamping)"
Al termine della decalcificazione, l'apparecchio richiede un altro risciacquo	Durante il ciclo di risciacquo, il serbatoio non è stato riempito fino al livello MAX	Ripetere il risciacquo (vedi cap. "11. Decalcificazione")
L'apparecchio non macina il caffè	All'interno del macinacaffè è presente un corpo estraneo	Procedere alla pulizia delle macine come indicato al par. "8.3 Pulizia delle macine", assicurandosi di aver rimosso tutti i chicchi dal contenitore chicchi (A2) prima di estrarlo. Prima di reinserire la macina, aspirare accuratamente ogni residuo dalla sua sede
	Il contenitore chicchi (A2) non è in posizione corretta	Il contenitore è inserito correttamente quando la freccia ▲ è allineata al simbolo  e si sente un "click"
Se si desidera cambiare qualità di caffè	È necessario eliminare tutti i chicchi presenti nella macchina	<ul style="list-style-type: none"> • Svuotare il contenitore chicchi (A2) (facendo delle macinature a vuoto o eventualmente aspirando i chicchi residui) • Agganciare la coppetta portafiltro (C1) e fare delle macinature "a vuoto" per liberare il condotto caffè: agganciare quindi il portafiltro all'uscita macinacaffè (A19) allineandolo alla scritta INSERT e ruotare verso destra la coppetta. La macinatura inizia quando la coppetta raggiunge la posizione CLOSE e si interrompe automaticamente. Ripetere finché il filtro rimane vuoto • Inserire nel contenitore (A2) la nuova varietà di chicchi di caffè • Se alla macinatura non si raggiunge la "dose perfetta", procedere come al primo utilizzo
		→

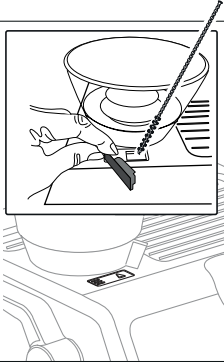
PROBLEMA	CAUSA	SOLUZIONE
<p>Dopo la macinatura, il filtro caffè (C2) o (C3) è vuoto</p> <p>Dopo la macinatura, la polvere caffè nel filtro è sovrabbondante</p>	<p>Lo scivolo caffè del macinacaffè è intasato</p>	<p>Procedere alla pulizia come indicato al par. "8.5 Pulizia della "Smart tamping station"". Se il problema persiste, accedere allo scivolo aprendo l'apposito sportellino (A21) e liberarlo utilizzando lo scovolino</p> 
<p>Dopo la macinatura, la polvere caffè nel filtro (C2) o (C3) non raggiunge la "dose perfetta"</p>	<p>La "Smart Tamping Station" necessita pulizia</p> <p>È necessario regolare la quantità di caffè macinato</p> <p>Con il tempo le macine si usurano</p>	<p>Procedere alla pulizia come indicato al par. "8.5 Pulizia della "Smart tamping station"", quindi ripetere la macinatura</p> <p>Regolare la quantità con la manopola dedicata (B2) seguendo le indicazioni al par. La "dose perfetta". Se la manopola è già in posizione max, procedere come indicato nella sezione "7. Menù impostazioni" - "Regolazione extra della macinatura"</p> <p>Procedere alla sostituzione delle macine come indicato al par. "8.4 Sostituzione delle macine"</p>

Before using the appliance, always read the safety warnings.

1. DESCRIPTION

1.1 Description of appliance - A

- A1. Beans container lid
- A2. Beans container
- A3. Cup tray
- A4. Steam dial
- A5. Hot water spout
- A6. Steam wand
- A7. Cup grille for espresso
- A8. Cup grille for glasses or mugs
- A9. Drip tray grille
- A10. Drip tray
- A11. Drip tray water level indicator
- A12. Water tank lid
- A13. Water tank extraction handle
- A14. Water tank
- A15. Water softener filter housing
- A16. Power cord connector socket
- A17. Main switch (ON/OFF)
- A18. Coffee spout
- A19. Coffee mill outlet (tamping station)
- A20. Presser lever
- A21. Cover giving access to coffee mill funnel

1.2 Description of control panel - B

- B1. ON/Standby button
- B2. Ground coffee quantity dial
- B3. "2x" button: selection of 2-coffee filter
- B4. Coffee temperature button
- B5. "OK" button: delivery of beverage/confirm
- B6. Hot water button
- B7. "My" button: customization of beverage quantity
- B8. Function selector dial
 - Espresso
 - Americano
 - Coffee
 - Descale
- B9. "Descale" light
- B10. "Steam ready" light
- B11. "No beans container" light
- B12. "Energy saving" light
- B13. "Clean" light (see "8.1 Cleaning of the coffee outlet")
- B14. "Beans container empty" light
- B15. "No water" light
- B16. "Press" light
- B17. Pressure gauge

1.3 Description of accessories - C

- C1. Filter holder
- C2. 1 cup filter
- C3. 2 cup filter
- C4. "Total Hardness Test" paper
- C5. Descaler
- C6. Removable power cord
- C7. Tube brush
- C8. Coffee outlet cleaning accessory
- C9. Softballs
- C10. Milk jug
- C11. Steam wand cleaning needle

1.4 Optional cleaning accessories recommended by the manufacturer

For more information, visit www.delonghi.com.



Cleaning tabs

(see "8.1 Cleaning the coffee outlet")

EcoMultiClean Cleaner

EAN: 800439933307

2. PREPARING THE APPLIANCE

Wash all accessories with warm water and washing-up liquid, then proceed as follows:

1. Locate the beans container in the (A2) coffee mill (fig. 1). The container is correctly in place when the arrow ▲ aligns with the ☐ symbol and a "click" is heard (fig. 2).
2. Locate the drip tray (A10) together with the cup grille (A8) and drip tray grille (A9) (fig. 3);
3. Take out the water tank (A14) (fig. 4) and fill with fresh clean water, taking care not to exceed the MAX level (fig. 5).
4. Put the tank back in the appliance.

Important: *Never operate the appliance without water in the tank or without the tank.*

Please note: *You should customise water hardness as soon as possible following the instructions in section "7. Settings menu".*

3. SETTING UP THE APPLIANCE

1. Plug the power cord connector (C6) into the socket (A16) at the back of the appliance (fig. 6), then plug into the mains socket. Make sure the main switch (A17) at the back of the appliance is pressed and in the I position (fig. 7);
2. Place a container of at least 100 ml capacity under the hot water spout (next to the coffee spout (A18)) as illustrated (fig. 8).
3. Press the button (B6) next to the ☐ indicator light (fig. 9): delivery will start and then stop automatically. Empty the container.

Before using the coffee maker, the internal circuits of the machine must be rinsed. Proceed as follows:

4. Attach the filter holder (C1) complete with filter to the appliance. To attach correctly, align the filter holder handle with

"INSERT" (fig. 10), then turn the handle to the right until it is aligned in the "CLOSE" position;

- Place a container under the filter holder and the steam wand (A6);
- Press the OK button (B5): delivery will start (fig. 11);
- When delivery has finished, turn the steam dial (A4) (fig. 12) and release the jet for a few seconds so as to rinse the steam circuit: to ensure best possible results, repeat the operation 3 or 4 times. The purpose of this procedure is to purge any water from the circuit before using steam to prepare a beverage.

The appliance is ready for use.

Please note: *We also recommend rinsing the internal circuits if the appliance is not used for a long period.*

The first time you use the appliance, you need to make 4-5 cups of coffee before the appliance starts to give satisfactory results. Pay particular attention to the quantity of pre-ground coffee in the filter ((C2) or (C3)) (see instructions in section "4.1 Step 1 - Grinding").

Proceed as described in section "The "perfect dose"".

4. PREPARATION OF COFFEE

4.1 Step 1 - Grinding

- Put coffee beans in the container (A2) (fig. 13). It is best to grind only a quantity of beans sufficient for immediate use, so that the coffee will always be fresh.
- Select the grinding level (fig. 14). The factory setting is 5 (medium ground). If this is too fine or too coarse, adjust the level according to personal taste and to the type of coffee being used (the adjustment must be made only when the coffee mill is in operation).

Please note: *A grinding level between 3 and 6 is recommended for most coffees. A grinding level of 1 or 2 is very fine and should be used with special coffees only (light roasted)*

- Place the ground coffee filter (C2) or (C3) in the filter holder (C1) (fig. 15); If the 2-cup filter is in use, press the 2x button (B3): this will also double the quantity of espresso coffee delivered from the spout.
- Set the quantity by adjusting the dial (B2), starting from the minimum position (fig. 16).

Refer to the section on "Adjusting the quantity of ground coffee in the filter" for further indications.

- Attach the filter holder to the outlet of the coffee mill (A19), aligning it with "INSERT", then turning it to the right. Grinding begins when the filter holder reaches the CLOSE position, then stops automatically.

Adjusting the quantity of ground coffee in the filter

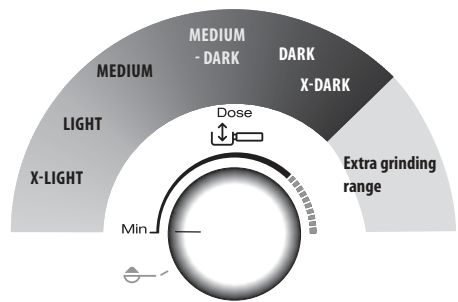

Different varieties of coffee bean give different results when ground: consequently, the initial adjustment of the dosage requires special care.

This illustration shows how to regulate the dosage, based on the roast colour: this should be taken as a general guide, given that in practice, the final adjustment can vary according to the composition of the beans.

- Set the dosage starting from the minimum position.
- Looking at the roast colour of your particular beans, turn the dial slowly to find the right adjustment.

4.2 Step 2 - Tamping

- Following the grinding step, bring the tamping lever (A20) down completely (keeping the filter in place under the outlet) (fig. 17). For a perfect result, repeat the step twice.
- Keep the tamping lever fully down when removing the filter holder (fig 18) and then return the lever to its initial position.
- Having checked that the dosage is as required (see "The "perfect dose"", attach the filter holder to the brewer outlet (A18) (fig. 19).

Please note: *Coffee left on the edges of the filter after pressing does not in any way compromise the quality of the brewing and therefore the end result.*

The "perfect dose"

- A reference mark inside the coffee filters identifies the perfect quantity.

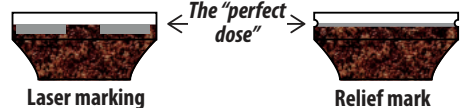

- Laser marked filters: the perfect quantity corresponds to the top line of the mark.
- Filters with relief mark: the perfect quantity corresponds to the line in relief.
- Make sure the coffee is at the right level after tamping. It might be necessary to adjust the level a few times using the dial (B2) before the ideal dosage is achieved.

- If the coffee is extracted too strongly or too weakly even at the ideal dosage, this can be corrected by grinding the beans more finely or more coarsely (see “4.1 Step 1 - Grinding”). To correct over-extraction (coffee released too slowly), select a coarser setting. To correct under-extraction (coffee released too quickly), select a finer setting.
- **Barista tips:** Draw the filter holder away from the tamper with the lever (A20) still down, so that the dose of coffee has a perfectly smooth finish.
- **When using pre-ground coffee:**
 - spoon the pre-ground coffee into the filter;
 - turn the dial to ;
 - attach the filter holder to the grinder outlet;
 - lower the tamping lever.







4.3 Step 3 - Brewing

1. Select the temperature (fig. 20) (see “Coffee preparation temperature”).
2. Select the desired beverage (fig. 21).
3. Press OK (B5) to start brewing (fig. 11) (pre-infusion and infusion). Delivery of the coffee will stop automatically.

Coffee preparation temperature

The water temperature is controlled during the entire preparation process to ensure its stability during the extraction step. The Specialista Prestigio offers 3 infusion temperatures* set in a range between 92 and 96 °C.

The temperature effectively utilized will depend typically on the variety of bean and the roast: Robusta beans require a lower temperature, and Arabica beans a higher temperature. The same applies for dark roasted beans or for light roasted beans, respectively.

Temperature level	Corresponding indicator light	Roast colour
MIN	 	Dark
MED	 	Medium-dark
MAX	 	Light - Medium

* This is the temperature of the water in the thermoblock. It is therefore not the temperature of the beverage in the cup or the temperature of the beverage at the moment of release from the outlets of the filter holder.

5. MAKING MILK BEVERAGES

5.1 Frothing the milk

1. Fill the jug (C10) with the amount of milk to be warmed/frothed, bearing in mind that the volume of the milk will increase 2- or 3-fold (fig. 22). For a denser and more evenly distributed froth, best results will be achieved using whole cow's milk at refrigerator temperature (about 5 °C).

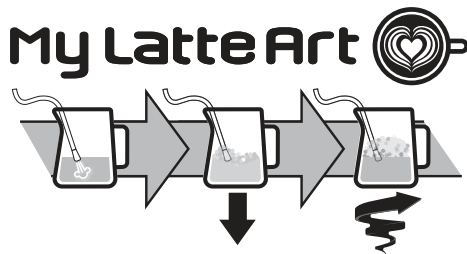

2. To froth the milk, offer the nozzle of the steam wand (A6) to the surface of the liquid: this will allow air to mix with the milk and steam.
3. Keep the steam nozzle just in contact with the surface, taking care not to let in too much air and create unsuitably large bubbles.
4. Immerse the nozzle just beneath the surface of the milk: this will create a vortex in the liquid. Once the milk is heated to the desired temperature, turn off the steam and wait for the flow to stop completely before removing the milk jug from the machine.

Barista tips:

- **Fresh milk is best.** Always use fresh milk straight from the fridge.
- For best results, always replace the milk jug in the fridge when not in use.
- Whole milk ensures optimum results. The appearance and texture of froth depending on the nature of the dairy milk or vegetable beverages utilized.
- After frothing the milk, eliminate unwanted bubbles by swirling the jug gently.

Cleaning the steam wand:

1. Following use, always wipe the steam wand (fig. 23) with a cloth to remove residual deposits of milk. The recommended procedure for in-depth cleaning is to use Eco MultiClean: this product ensures maximum hygiene by removing milk proteins and fats, and can be used for cleaning the entire machine.
2. Release steam for a few seconds to clean the wand (fig. 12).
3. Wait until the steam wand has cooled down: to ensure the wand works efficiently over time, use the special cleaning tool (C11) to free the 3 holes (fig. 24) of any obstruction.







6. CUSTOMISING THE QUANTITY OF COFFEE BEVERAGES WITH THE (my) BUTTON (B7)

1. Prepare the appliance to deliver 1 or 2 cups of the coffee beverage you want to make, as far as attaching the filter holder (C1) complete with the (C2) or (C3) filter and ground coffee.
2. Turn the dial (B8) to select the beverage being programmed.
3. Press the (my) button: the light associated with the (my) button blinks.
4. Press the OK button to start delivery. The lights associated with the Ok and (my) buttons blink.
5. When the required quantity is reached, press OK. If the beverage includes another ingredient, the machine will start delivering this one as well: once the required quantity has been reached, press OK.
6. Press the (my) button to save. The appliance is now ready again for further use and the (my) light remains on.

If there is no wish to save the new setting, simply press any other button.









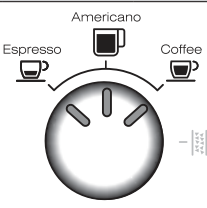

Please note:

- Coffee beverages can be programmed, but the delivery of steam and hot water can not.
- Programming changes the quantity of beverage delivered, but not the quantity of ground coffee
- "2x" beverages can be programmed separately.
- **To restore the default factory settings, press and hold the (my) button until the light goes off.** The selected beverage reverts to the default quantity.

Coffee recipe	Default quantity	Programmable quantity
 Espresso	35 ml	from 25 to 90 ml
 Espresso 2x	70 ml	from 50 to 180 ml
 Coffee	80 ml	from 50 to 120 ml
 Coffee 2x	160 ml	from 120 to 240 ml
 Americano	120 ml	<ul style="list-style-type: none"> • espresso: from 25 to 60 ml • water: from 25 to 120 ml
 Americano 2x	240 ml	<ul style="list-style-type: none"> • espresso: from 50 to 120 ml • water: from 50 to 240 ml

7. SETTINGS MENU

1. Enter the menu:
→

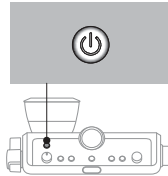
Press together and hold for 5 seconds	2x	(my)
2. Settings selected with dial (B8)		
		
Corresponding setting	Turn to	Adjustments
Extra grinding adjustment	 Espresso	×2 → Range 1
		 → Range 2
Water hardness	 Americano	×2 → soft
		 → medium
		 → hard/very hard
Auto-off	 Coffee	×2 → 9 minutes
		 → 1.5 hours
		 → 3 hours
3. Settings selected with buttons		
Energy saving	 → Active	
	 → Off	
Default values	Press the button and hold for at least 5 seconds (my), until the light remains permanently on	
4. Save the new settings by pressing ON/Standby (B1)		
		











8. CLEANING THE APPLIANCE

Important!

- Do not use solvents, abrasive detergents or alcohol to clean the coffee machine.
- Do not use metal objects to remove encrustations or coffee deposits as they could scratch metal or plastic surfaces.
- Should the machine remain idle for more than a week, it is advisable to carry out a rinse cycle before preparing any beverages.

Danger!



- Never immerse the coffee maker in water when cleaning: it is an electrical appliance.
- Before commencing any cleaning operation on the outside of the machine, turn it off, unplug it from the mains socket and wait for it to cool down.

					
	✗	✓	✓	✗	✗
	✓	✗	✗	✓	✓
	✗	✗	✗	✓	✓
	✗	✗	✗	✓	✓
	✗	✗	✓	✓	✗
	✗	✗	✗	✓	✓

8.1 Cleaning the coffee outlet

When  light comes on (orange) (B13), it means that the coffee circuit needs to be cleaned. This requires special cleaning tabs for coffee makers, which must be purchased separately. For more information, visit www.Delonghi.com.



- Insert the 1-cup filter (C2) in the holder (C1) (fig. 25).
- Position the cleaning accessory in the filter (C8) (fig. 25) and press home.
- Place the cleaning tab on the accessory (fig. 26).
- Attach the filter holder to the coffee outlet (A18).
- Fill the tank(A14) with water. Make sure the drip tray (A10) is empty.

- Press and hold the  button (B6) until the light  (B13) comes on. After a few minutes, the cleaning cycle stops automatically.
- Remove the filter holder and the cleaning accessory.
- Wash the filter holder and the filter under running water.
- Attach the filter holder again and run a rinse cycle by pressing the  button: it is advisable to place a container under the filter holder.
- Remove and empty the drip tray.

Please note:

This cleaning cycle can be initiated at any time by pressing the  button and holding for a few seconds. To cancel, press and hold the button for at least 10 seconds.

8.2 Cleaning the beans container housing

- Make sure the beans container (A2) is empty. If in doubt, operate the mill briefly to make certain.
- Release the container by turning it anticlockwise and detach it from the machine (fig. 27).
- Remove coffee residues using a vacuum cleaner (fig. 28).
- Clean the beans container housing with a moist cloth, and wipe dry (fig. 29);
- Reposition the beans container in the coffee mill. The container is correctly in place when the arrow  is aligned with the  symbol and a "click" is heard (fig.30).

8.3 Cleaning the burrs

When cleaning the beans container (A2), clean the container housing and the top burr with a moist cloth. If the burrs need to be removed and replaced, contact a service centre.

The burr can be removed in the event of the coffee mill being jammed by the presence of foreign matter. Should this occur, remove the beans container and proceed as follows:

- Attach the filter holder (C1) and operate the mill briefly without beans to free the internal duct.
- Turn the appliance off.
- Turn the grinding adjustment dial anticlockwise as far as it will go, which is the "REMOVE" position (fig. 31).
- Gripping the top burr by the handle, pull it up and out of the housing (fig.32).
- Clean the burr with a brush (fig. 33) and remove coffee residues using a vacuum cleaner (fig. 28).

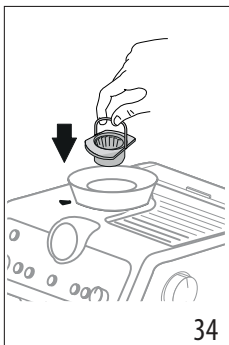
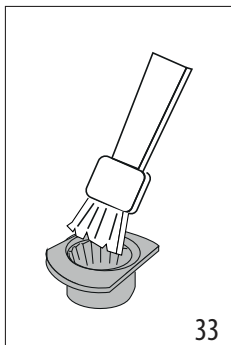

6. Replace the burr in the housing (fig. 34);
7. Turn the adjustment dial to select the desired grinding level (fig. 14);

Check that the burr is properly seated by pulling on the handle: if it is correctly in place, it will not move.

8.4 Replacing the burrs

When the quantity of ground coffee becomes less than expected, contact a service centre to have the burrs replaced: with the new burrs fitted, adjust the coffee mill by accessing the settings menu ("7. Settings menu") and selecting the first range of the "extra grinding adjustment" setting. Next, turn the ground coffee quantity adjustment dial (B2) to the MIN position and set the dose as for first-time use (see "The "perfect dose"").

8.5 Cleaning the "Smart tamping station"

1. Clean the attachment area with a brush (fig. 35).
2. Pull the lever (A20) down completely and clean the tamper with a brush (fig. 36), then release the lever.
3. Use the tube brush (C7) to clean the coffee funnel (fig. 37).

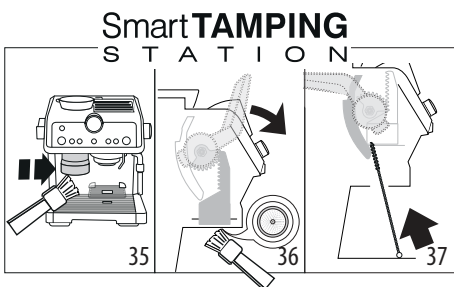

9. WATER HARDNESS

The descale light  (B9) comes on following a predetermined period of operation that depends on a water hardness setting. The machine can also be programmed according to the actual hardness of the local water supply, in which case descaling may be required less frequently.

1. Remove the "TOTAL HARDNESS TEST" indicator paper (C4) from its pack.
2. Immerse the paper completely in a glass of water for one second.
3. Remove the paper from the water and shake lightly. Set the machine accordingly, as indicated in the section "7. Settings menu".

Water Hardness Test Result	Button	Level
	×2	1 soft water
	≡ ⚙️	2 medium water
	OK	3 hard or very hard water

4. Set the machine accordingly, as indicated in the section "7. Settings menu".

10. HOW TO USE SOFTBALLS

Softballs (C9) are an innovative treatment system that prolongs the life of the machine, without altering the properties of the water, while ensuring consistently creamy and aromatic coffee. To optimize the effectiveness of the treatment, leave Softballs in the water overnight before use.

1. Take the sachet of Softballs from the wrapper (fig. 38).

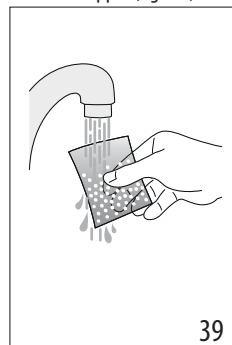
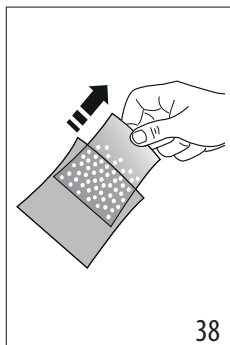

2. Rinse the sachet of Softballs under running water (fig. 39).
3. Immerse the sachet in the water tank (A14) (fig. 40).

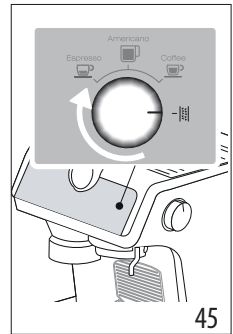
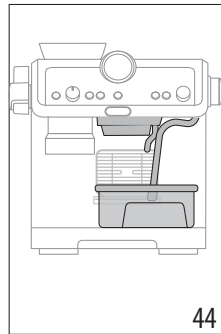
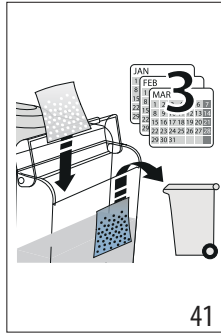
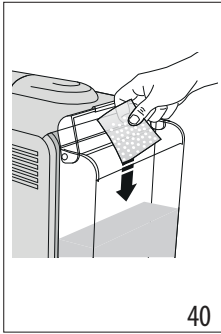

- Change the sachet of Softballs every 3 months (fig. 41).

11. DESCALING

Important!

- Before using the descaler, (C5) read the instructions and the labelling on the pack.
- Use De'Longhi descaler only. Using unsuitable descaler products and/or performing the descale procedure incorrectly could give rise to faults not covered by the manufacturer's guarantee.
- Descaler can cause damage to delicate surfaces. If the product is accidentally spilt, dry immediately.

To descale	
Descaler	De'Longhi descaler
Container	Capacity 2 litres
Time	~40min

- (REMOVE WATER SOFTENER AND SOFTBALLS, IF PRESENT). Pour the descaler into the water tank (A14) up to the first level **A** marked on the inside of the tank (which corresponds to the contents of one 100ml pack) (fig. 42).

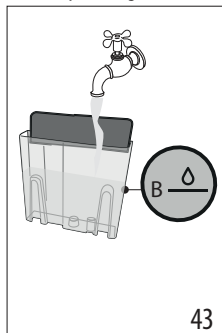
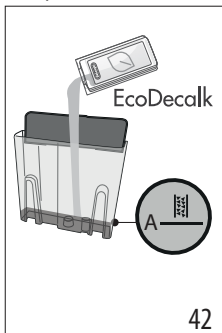

- Add water up to level **B** (fig. 43). Now reposition the water tank in the machine.

- Make sure that the filter holder (C1) is not attached. Position a container under the coffee outlet and the hot water spout, and another under the steam wand (A6) (fig. 44).

- Turn the knob (B8) to (fig. 45): the OK light comes on, orange in colour and the light blinks.

- Press the OK button: the OK light blinks.
- The descaling programme starts and the descaler liquid comes out of the spouts. The descale programme removes limescale deposits from inside the appliance by automatically performing a series of rinses and pauses until the tank is empty.

Descaling ceases and the colour of the OK light turns to white. This means that a rinse cycle must be carried out:

- Empty the containers used to collect the descaler solution and reposition them under the spouts.
- Remove the water tank, empty out any residual descaler solution, rinse under running water and fill with fresh water up to the MAX level (fig. 46). Put the tank back in its housing.

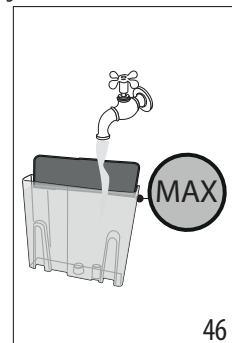

- Press the OK button: the rinse cycle will start.
- Once the rinse cycle has been completed, water will stop draining out and the machine is ready for use.
- Empty the containers used to collect the rinse water.
- Remove and empty the drip tray, then reposition it in the machine.









13. Remove the tank, fill with fresh water, and reposition in the machine.





The machine is now ready for use.







Please note:



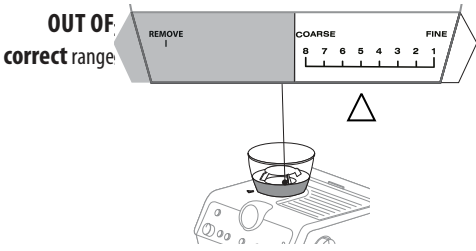

- The descaling cycle can be started up at any time (even if the relative light has not yet come on).
- Should descaling be started up by mistake, it can be stopped by pressing the OK button and holding for 10 seconds; the rinse cycle cannot be stopped.

12. EXPLANATION OF INDICATOR LIGHTS



LIGHTS	EXPLANATION OF LIGHTS	OPERATION
All lights blink briefly	Turning the machine on	Self-diagnosis
 permanently on	The machine has been turned on for the first time and the water circuit must be filled	Proceed as indicated in section “3. Setting up the appliance”
 permanently on (white) <ul style="list-style-type: none"> •  light: indicates the selected coffee temperature •  light: indicates the machine is ready to deliver hot water 	The machine is ready to deliver fluids	Set up the machine and proceed with preparation of the beverage
 permanently on	Energy saving is enabled	Refer to section “7. Settings menu” for instructions on disabling the function
 permanently on	The beans container (A2) is empty	Fill the beans container
 blinking	The grinding function has been selected, but the beans container (A2) is empty	Fill the beans container
 blinking momentarily at regular intervals	The dial (B2) has been set to the MAX adjustment	When the freshly ground coffee in the filter is not sufficient, select a new grinding range as indicated in section “6. Menu settings”.
 permanently on	There is not enough water in the tank (A14) or the tank is not correctly in place	Fill the tank with water, or remove the tank and reposition it correctly
→		

LIGHTS	EXPLANATION OF LIGHTS	OPERATION
 blinking	An attempt is being made to prepare a beverage, but with water tank (A14) empty	Fill the tank with water
	Because the beans are too finely ground, the coffee is delivered too slowly or not at all	Remove the filter holder (C1) and repeat the coffee-making steps, bearing in the mind the indications given in sections “4.1 Step 1 - Grinding” and “4.2 Step 2 - Tamping”
	The coffee filter (C2) or (C3) is obstructed	Rinse the filters under running water
	The tank (A14) is not properly in place and the relative valves are not open	Press down lightly on the tank to open the valves
	Limescale in the water circuit	Descale as described in section “11. Descaling”
 permanently on	The machine is ready to deliver steam	The machine is at the right temperature to deliver steam. To deliver steam from the wand, turn the steam dial (A4)
 blinking	The machine is switched on and energy saving is enabled. The steam dial (A4) is in the steam delivery position	The indicator light blinks to indicate that the machine is preparing to deliver steam. Delivery begins as soon as the steam circuit is up to temperature
	The machine is ready to deliver steam	The machine is at the right temperature to provide steam when the light remains permanently on
	The machine is delivering steam	
 permanently on	The beans container is not in place	Position the beans container (A2) correctly, or check that it is correctly in place The container is correctly in place when the arrow ▲ is aligned with the  symbol and a “click” is heard
→		

LIGHTS	EXPLANATION OF LIGHTS	OPERATION
 blinking	<p>The setting of the grinding level adjustment selector is incorrect, or beyond the maximum adjustment possible</p>	<p>Return the selector to one of the regular settings (between 1 and 8), remembering that:</p> <ul style="list-style-type: none"> • The grinding adjustment must be made with the mill in operation • The mill should be adjusted one level at a time, and used at least 5 times between one adjustment and the next
	<p>OUT OF correct range</p>  <p>Correct range</p>	
 permanently on	<p>The machine calls for tamping</p>	<p>The coffee has just been ground and the filter holder is attached to the coffee mill</p>
	<p>The filter holder has been detached from the coffee mill without tamping</p>	<p>Release the filter holder and proceed, tamping the coffee as described in section “The “perfect dose”” “When using pre-ground coffee:”</p>
	<p>The filter holder has been released with grinding incomplete, or the tamping step has occurred too quickly</p>	<p>Repeat the grinding step</p>
	<p>The coffee mill funnel is clogged</p>	<p>Clean as described in section “8.5 Cleaning the “Smart tamping station””. If the problem persists, access the funnel by opening the relative cover and clear the blockage using the tube brush</p>
	<p>The burrs are jammed by foreign matter</p>	<p>Remove the foreign matter and clean the burrs as indicated in section “8.3 Cleaning the burrs”.</p>
 permanently on (red)	<p>Descaling is required</p>	<p>Carry out descaling as described in section “11. Descaling”</p>
 blinks (red) +  blinks (orange)	<p>Descaling is in progress</p>	<p>Complete the operation as described in section “11. Descaling”</p>
 blinks (red) +  permanently on (white)	<p>Rinsing is required</p>	
→		

LIGHTS	EXPLANATION OF LIGHTS	OPERATION
 blinks (red) +  blinks (white)	Rinsing is in progress following completion of the descale cycle	
 permanently on (orange)	The coffee outlet requires cleaning	See section “8.1 Cleaning the coffee outlet”
 blinking (orange)	Cleaning of the coffee outlet is in progress	
All indicator lights blink	General alarm	Contact Customer Services

13. TROUBLESHOOTING

PROBLEM	CAUSE	SOLUTION
There is water in the drip tray (A10)	This water comes from the internal circuits of the machine and is a normal consequence of their operation	Empty and clean the drip tray on a regular basis
The machine fails to produce espresso coffee	No water in the tank (A14)	Fill the tank
	The  (B6) light is on, meaning that the coffee circuit or the steam circuit is empty	Press the button associated with the  light to fill the circuit
	Blockage in the coffee filter (C2) or (C3)	Rinse the filters under running water
	The tank (A14) is not properly in place and the valves at the bottom are not open	Press down lightly on the tank to open the valves at the bottom
	Limescale in the water circuit	Descale as described in section “11. Descaling”
	Coffee ground too finely	Remove the filter holder (C1) and repeat the coffee-making steps, bearing in the mind the indications given in sections “4.1 Step 1 - Grinding” and “4.2 Step 2 - Tamping”
The filter holder cannot be attached to the coffee outlet	The ground coffee has not been tamped or the quantity is excessive	Repeat the grinding step with different settings. Reduce the dosage quantity: check that the filter (C2) or (C3) (1 or 2 cups) and the grinding dosage are correctly matched (2x button (B3) selected or otherwise)
The espresso coffee drips from the edges of the filter holder (C1) instead of from the holes	The filter holder is not properly attached	Attach the filter holder correctly and rotate firmly as far as it will go
	The seal of the coffee outlet (A18) has lost flexibility or is dirty	Have the coffee outlet seal replaced by a Service Centre
	Blockage in the coffee filter (C2) or (C3)	Rinse the filters under running water
		→

PROBLEM	CAUSE	SOLUTION
The espresso cream is too white (delivered from the spout too fast)	The machine settings need to be reappraised	Remove the filter holder and repeat the coffee-making steps, bearing in the mind the indications given in sections "4.1 Step 1 - Grinding" and "4.2 Step 2 - Tamping"
The espresso cream is too dark (delivered from the spout too slowly)	The machine settings need to be reappraised	Remove the filter holder (C1) and repeat the coffee-making steps, bearing in the mind the indications given in sections "4.1 Step 1 - Grinding" and "4.2 Step 2 - Tamping"
On completion of the descale cycle, the machine calls for a further rinse	During the rinse cycle, the water tank has not been filled to the MAX level	Repeat the rinse cycle (see section "11. Descaling")
The machine does not grind the coffee	Foreign matter has found its way into the coffee mill	Clean the burrs as described in section "8.3 Cleaning the burrs", making sure you remove all the beans from the beans container (A2) before extracting it. Before putting the burr back, vacuum all residues from the housing
	The beans container (A2) is not correctly positioned	The container is correctly in place when the arrow ▲ is aligned with the ☐ symbol and a "click" is heard
Changing to a different type of coffee	All beans currently in the machine must first be removed	<ul style="list-style-type: none"> • Empty the beans container (A2) (operating the coffee mill without beans or removing any beans still present with a vacuum cleaner) • Attach the filter holder (C1) and operate the mill a few times without beans to free the internal duct: now attach the filter holder to the coffee mill outlet (A19) aligning it with the INSERT mark, and turn it to the right. Grinding begins when the filter holder reaches the CLOSE position, then stops automatically. Repeat until the filter is empty • Fill the container (A2) with the new variety of coffee beans • If the amount of ground coffee does not give the perfect dose, proceed to set up the machine as for first-time use
		→

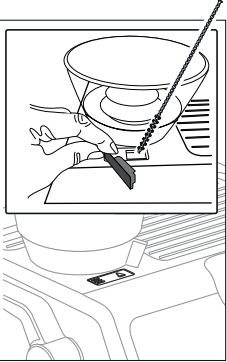
PROBLEM	CAUSE	SOLUTION
<p>After grinding, the coffee filter (C2) or (C3) is empty</p> <p>After grinding, there is too much coffee in the filter</p>	<p>The funnel of the coffee mill is clogged</p>	<p>Clean as described in section "8.5 Cleaning the "Smart tamping station"". If the problem persists, access the funnel by opening the relative cover (A21) and clear the blockage using the tube brush</p> 
<p>After grinding, the amount of coffee in the filter (C2) or (C3) does not give the "perfect dose"</p>	<p>The "Smart Tamping Station" needs cleaning</p> <p>The quantity of ground coffee needs adjusting</p> <p>Over time the burrs wear down</p>	<p>Clean as described in section "8.5 Cleaning the "Smart tamping station"", then repeat the grinding step</p> <p>Adjust the quantity of coffee with the dial (B2), following the instructions in section "The "perfect dose"". If the dial is already in the max. position, proceed as described in section "7. Settings menu" - "Extra grinding adjustment"</p> <p>Have the burrs replaced as indicated in section "8.4 Replacing the burrs".</p>

Avant d'utiliser l'appareil toujours lire la brochure des consignes de sécurité.

1. DESCRIPTION

1.1 Description de l'appareil - A

- A1. Couvercle du réservoir à grains
- A2. Réservoir à grains
- A3. Grille d'appui pour tasses
- A4. Manette vapeur
- A5. Buse à eau chaude
- A6. Tube buse vapeur
- A7. Grille d'appui pour tasses espresso
- A8. Grille d'appui pour verres ou mugs
- A9. Grille égouttoir
- A10. Égouttoir
- A11. Indicateur du niveau de l'eau dans l'égouttoir
- A12. Couvercle réservoir d'eau
- A13. Poignée extraction réservoir d'eau
- A14. Réservoir d'eau
- A15. Logement filtre adoucisseur
- A16. Logement connecteur cordon d'alimentation
- A17. Interrupteur général (ON/OFF)
- A18. Buse à café
- A19. Sortie moulin à café (Tamping station)
- A20. Levier tasseur
- A21. Volet pour accéder à la goulotte du moulin à café

1.2 Description panneau de contrôle - B

- B1. Touche ON/Veille
- B2. Bouton de réglage de la quantité de café moulu
- B3. Touche « X2 » : pour utiliser le filtre 2 cafés
- B4. Touche « température café »
- B5. Touche « OK » : pour préparer la boisson/pour confirmer
- B6. Touche « écoulement eau chaude »
- B7. Touche « My » : pour personnaliser la longueur des boissons
- B8. Bouton de sélection fonctions
 - Espresso
 - Americano
 - Café
 - Détartrage
- B9. Voyant « détartrage »
- B10. Voyant « vapeur prête »
- B11. Voyant « absence réservoir à grains »
- B12. Voyant « économie d'énergie »
- B13. Voyant « Nettoyage » (voir « 8.1 Nettoyage de la buse à café »)
- B14. Voyant « réservoir à grains vide »
- B15. Voyant « manque d'eau »
- B16. Voyant « tassage »
- B17. Manomètre

1.3 Description des accessoires - C

- C1. Coupelle porte-filtre
- C2. Filtre 1 tasse
- C3. Filtre 2 tasses
- C4. Bande réactive « Total Hardness Test »
- C5. Détartrant
- C6. Cordon d'alimentation amovible
- C7. Écouvillon
- C8. Accessoire de nettoyage buse à café
- C9. Softballs
- C10. Pot à lait
- C11. Aiguille de nettoyage pour lance à vapeur

1.4 Accessoires de nettoyage non inclus, recommandés par le constructeur

Pour de plus amples informations, visitez Delonghi.com.

Pastilles de nettoyage

(Voir « 8.1 Nettoyage de la buse à café »)



Nettoyant
EAN : 8004399333307

2. PRÉPARATION DE L'APPAREIL

Laver tous les accessoires à l'eau tiède avec du savon à vaisselle puis procéder comme suit :

1. Insérer le réservoir à grains (A2) dans le moulin à café (fig. 1). Le réservoir est inséré correctement lorsque la flèche ▲ est alignée au symbole ☐ et que l'on entend un « clic » (fig. 2).
2. Insérer l'égouttoir (A10) avec la grille d'appui pour tasses (A8) et la grille égouttoir (A9) (fig. 3) ;
3. Extraire le réservoir d'eau (A14) (fig. 4) et le remplir d'eau fraîche et propre en veillant à ne pas dépasser l'inscription MAX (fig. 5).
4. Puis réinsérer le réservoir.

Attention : Ne jamais mettre en marche l'appareil sans eau dans le réservoir ou sans réservoir.

Nota bene : Il est conseillé de personnaliser le plus rapidement possible la dureté de l'eau en suivant la procédure décrite dans le chapitre « 7. Menu paramètres ».

3. PREMIÈRE MISE EN MARCHÉ DE LA MACHINE

1. Insérer le connecteur du cordon d'alimentation (C6) dans le logement prévu à cet effet (A16) à l'arrière de l'appareil (fig. 6) ; puis brancher la fiche sur la prise. S'assurer et vérifier que l'interrupteur général (A17), au dos de l'appareil, est enfoncé sur la position I (fig. 7) ;
2. Positionner un récipient ayant une capacité minimale de 100 ml sous la buse à eau chaude (au niveau de la buse à café (A18)) (fig. 8) ;
3. Appuyer sur la touche (B6) au niveau du voyant ☐ (fig. 9) : l'écoulement commence et s'interrompt automatiquement. Vider le récipient.

Avant de commencer à utiliser la machine, il faut rincer les circuits internes de la machine. Procéder de la manière suivante :

4. Accrocher la coupelle porte-filtre (C1) munie du filtre à la machine : pour un accrochage correct, aligner la poignée de la coupelle porte-filtre à « INSERT » (fig. 10) et tourner la poignée vers la droite, jusqu'à l'aligner à la position « CLOSE » ;
5. Mettre un récipient sous la coupelle porte-filtre et le tube de la buse vapeur (A6) ;
6. Appuyer sur la touche OK (B5) (fig. 11) : la préparation commence ;
7. Une fois la préparation finie, tourner le bouton vapeur (A4) (fig. 12) et débiter de la vapeur pendant quelques secondes de manière à rincer le circuit vapeur : pour une distribution optimale de vapeur, on conseille de répéter cette opération 3 ou 4 fois. Ceci permet d'éliminer l'eau dans le tube avant de distribuer de la vapeur.

L'appareil est donc prêt à l'usage.

Nota bene : Le rinçage des circuits internes est conseillé même en cas d'inutilisation prolongée de l'appareil.

À la première utilisation il faut faire 4-5 cafés avant que la machine ne commence à donner un résultat satisfaisant : prêter une attention particulière à la dose de café moulu dans le filtre ((C2) ou (C3)) (voir instructions du paragraphe « 4.1 Phase 1 - Mouture (grinding) »).

Procéder comme indiqué au chapitre « La « dose parfaite » ».

4. PRÉPARER LE CAFÉ

4.1 Phase 1 - Mouture (grinding)

1. Verser les grains dans le réservoir (A2) (fig. 13). Il est recommandé de ne verser que les grains nécessaires à la préparation : de cette manière on utilisera toujours du café frais ;
2. Sélectionner le degré de mouture (fig. 14). Le paramètre d'usine est 5 (mouture moyenne). Si le résultat n'est pas satisfaisant, régler le niveau en fonction du goût personnel et du type de café (le réglage doit être effectué durant le fonctionnement du moulin à café).

Nota bene : Le degré de mouture entre 3 et 6 est conseillé pour la plupart des cafés. En sélectionnant 1 ou 2, on obtient une mouture très fine, à utiliser uniquement avec du café très particulier (torréfié léger).

3. Insérer l'un des filtres café (C2) ou (C3) dans le porte-filtre (C1) (fig. 15). Si l'on utilise le filtre pour 2 tasses, appuyer sur la touche X2 (B3) : cette sélection permet de doubler la quantité d'espresso préparée.
4. Régler le bouton quantité (B2) en partant de la position minimale (fig. 16).

Se référer au paragraphe « Régler la quantité de café moulu dans le filtre » pour de plus amples indications.

5. Accrocher le porte-filtre à la sortie du moulin à café (A19) en l'alignant à l'inscription INSERT : puis tourner la coupelle vers la droite. La mouture commence lorsque la coupelle atteint la position CLOSE et s'interrompt automatiquement.

Régler la quantité de café moulu dans le filtre

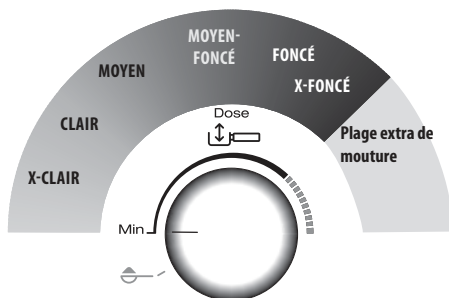

Chaque variété de grain donne un résultat différent durant la mouture c'est pourquoi, au début, le réglage de la dose demande le plus grand soin.

Cette illustration donne des indications sur la manière de régler la dose, basées sur la couleur de torréfaction : elles doivent être considérées comme un point de départ, mais peuvent varier suivant la composition des grains de café.

1. Programmer la dose en commençant par la position minimale.
2. En faisant référence à la couleur de torréfaction de votre café, tourner lentement le bouton.

4.2 Phase 2 - Tassage (tamping)

1. Après la mouture, abaisser le levier de tassage (A20) jusqu'en butée (ne pas enlever le porte-filtre) (fig. 17). Pour un résultat parfait, répéter 2 fois.
2. Maintenir le levier abaissé jusqu'en butée durant le retrait du porte-filtre (fig. 18). Puis ramener le levier dans la position initiale.
3. Après avoir vérifié que la dose est correcte (voir « La « dose parfaite » »), accrocher le porte-filtre à la buse à café (A18) (fig. 19).

Nota bene : Si après le tassage il reste du café le long des bords du filtre, cela ne compromet absolument pas la qualité de l'extraction et, donc, le résultat final.

La « dose parfaite »

- Les filtres café, ont un repère interne pour identifier la dose parfaite.



Marquage au laser

Marquage en relief

- Filtres avec marquage au laser : la dose parfaite correspond à la ligne supérieure du marquage ;
- Filtres avec marquage en relief : la dose parfaite correspond à la ligne en relief ;
- S'assurer que le café est à niveau après le tassage. Il pourrait être nécessaire de régler plusieurs fois le bouton (B2) avant de parvenir à la dose parfaite.
- Si le café est sur- ou sous-extrait et que la dose est à l'intérieur de la dose parfaite, régler le degré de mouture le plus fin ou le plus grossier (voir « 4.1 Phase 1 - Mouture (grinding) »). Si le café est sur-extrait (distribution trop lente) la mouture devra être plus grossière. Si le café est sous-extrait (distribution trop rapide) la mouture devra être plus fine.
- **Le barista conseille :** Extraire le porte-filtre alors que le levier du tasseur (A20) est abaissé pour obtenir une finition parfaite de la dose de café.
- **Si l'on utilise du café prémoulu :**
 - verser le café prémoulu dans le filtre ;
 - tourner le bouton sur  ;
 - accrocher le porte-filtre à la sortie du moulin à café ;
 - abaisser le levier de tassage.





4.3 Phase 3 - Distribution (brewing)

1. Sélectionner la température (fig. 20) (voir « La température pour préparer le café »).
2. Sélectionner la boisson souhaitée (fig. 21).
3. Appuyer sur OK (B5) pour commencer la distribution (fig. 11) (pré-infusion et infusion). La distribution du café s'interrompt automatiquement.

La température pour préparer le café

La température de l'eau est contrôlée durant tout le processus de préparation afin de garantir sa stabilité en phase d'extraction. La Specialista Prestigio offre 3 températures d'infusion* qui correspondent à une plage entre 92°C et 96°C.

On conseille une température différente en fonction de la variété et de la torréfaction des grains : les grains de Robusta requièrent une température basse ; les grains d'Arabica une température haute. Il en va de même pour les grains avec une torréfaction foncée ou pour les grains à peine torréfiés.

Niveau de température	Voyant correspondant	Niveau de torréfaction
MIN	 	Foncé
MOY	 	Moyen-foncé

MAX		Clair - moyen
------------	--	----------------------

- * Cette température fait référence à l'eau dans le thermoblock. Elle est donc différente de la température de la boisson en tasse ou de la température mesurée quand la boisson sort des buses du porte-filtre.

5. PRÉPARATION DE BOISSONS À BASE DE LAIT

5.1 Émulsionner le lait

1. Verser dans le pot (C10) la quantité de lait que l'on souhaite chauffer/émulsionner, en tenant compte du fait que le volume du lait augmentera de 2 à 3 fois (fig. 22). Pour obtenir une mousse plus dense et homogène, il est recommandé d'utiliser du lait de vache entier et à la température du réfrigérateur (environ 5°C).

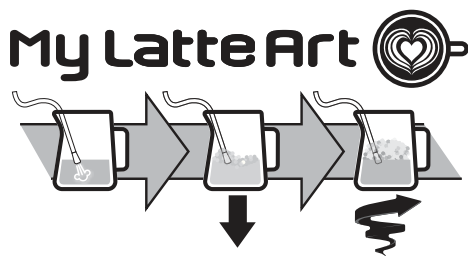

2. Pour émulsionner le lait, appuyer le tube buse vapeur (A6) sur la surface du lait : de cette façon l'air se mélange au lait et à la vapeur.
3. Maintenir la buse vapeur sur la surface, en veillant à ne pas capturer trop d'air en créant des bulles trop grosses.
4. Plonger la buse vapeur sous la surface du lait : de cette manière il se forme un tourbillon. Après avoir atteint la température souhaitée, refermer le bouton vapeur et attendre que la distribution de la vapeur s'interrompt complètement avant d'enlever le pot à lait.

Le barista conseille :

- **Le lait frais est meilleur.** Toujours utiliser du lait frais à la température du réfrigérateur.
- Pour un meilleur résultat, on conseille de mettre le pot à lait au réfrigérateur.
- Le lait entier assure d'excellents résultats. Le résultat et la texture de la mousse varient en fonction du lait de vache ou des boissons végétales utilisées.
- Après avoir émulsionné le lait, éliminer les bulles en faisant tourner légèrement le pot à lait.

Nettoyage de la buse vapeur :

1. Après chaque utilisation, éliminer les résidus de lait de la buse vapeur à l'aide d'un chiffon (fig. 23). Pour un

nettoyage profond, il est recommandé d'utiliser Eco MultiClean : il assure l'hygiène en éliminant les protéines et les graisses du lait et peut être utilisé pour nettoyer toute la machine.

- Distribuer de la vapeur pendant quelques secondes pour bien nettoyer la buse (fig. 12).
- Attendre que la buse refroidisse : pour maintenir l'efficacité de la buse dans le temps, utiliser l'aiguille de nettoyage (C11) pour maintenir libres les 3 trous (fig. 24).

6. PERSONNALISER LA LONGUEUR DES BOISSONS AU CAFÉ À L'AIDE DE LA TOUCHE



my (B7)





- Préparer la machine pour faire 1 ou 2 tasses de la boisson au café que l'on souhaite préparer, jusqu'à accrocher le porte-filtre (C1) doté de filtre (C2) ou (C3) et de café moulu.
- Tourner le bouton (B8) pour sélectionner la boisson à programmer.
- Appuyer sur la touche **my** : le voyant correspondant à la touche **my** clignote.
- Appuyer sur la touche OK pour commencer la distribution. Les voyants correspondants aux touches OK et **my** clignotent.
- Après avoir atteint la quantité souhaitée, appuyer sur OK. Si la boisson prévoit la préparation d'un autre ingrédient, la préparation de ce dernier commence : après avoir atteint la quantité souhaitée, appuyer sur OK.
- Appuyer sur la touche **my** pour enregistrer. L'appareil est prêt pour une nouvelle utilisation et le voyant **my** reste allumé.

Si l'on ne souhaite pas enregistrer la programmation, appuyer sur n'importe quelle autre touche.











Nota bene :

- Il est possible de programmer les boissons à base de café, mais non la distribution de vapeur et d'eau chaude.
- La programmation modifie les quantités des boissons, mais non du café moulu.
- Les boissons « X2 » peuvent être programmées séparément.
- Pour repasser aux paramètres d'usine, maintenir la touche **my** enfoncée jusqu'à l'arrêt. La boisson sélectionnée revient à la quantité d'usine.

Recette café	Quantité d'usine	Quantité programmable
 Espresso	35 ml	de 25 à 90 ml
 Espresso X2	70 ml	de 50 à 180 ml

Recette café	Quantité d'usine	Quantité programmable
 Coffee	80 ml	de 50 à 120 ml
 Coffee X2	160 ml	de 120 à 240 ml
 Americano	120 ml	<ul style="list-style-type: none"> espresso : de 25 à 60 ml eau : de 25 à 120 ml
 Americano X2	240 ml	<ul style="list-style-type: none"> espresso : de 50 à 120 ml eau : de 50 à 240 ml

7. MENU PARAMÈTRES

1. Entrer dans le menu :		
Presser simultanément pendant 5 secondes	x2	my
2. Paramètres avec sélection à partir du bouton (B8)		
		
Paramètre correspondant	Tourner sur	Réglages
Réglage extra de la mouture		x2 → Plage 1
		 → Plage 2
Dureté de l'eau		x2 → douce
		 → moyenne
		 → dure/très dure
Arrêt automatique		x2 → 9 minutes
		 → 1,5 heures
		 → 3 heures
3. Paramètre avec sélection à partir de la touche :		
Économie d'énergie		 → Activée
		 → Éteinte
→		

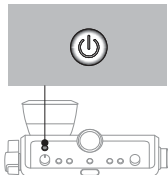
Valeurs d'usine	Maintenir enfoncée la touche my pendant au moins 5 secondes, jusqu'à ce que le voyant reste allumé fixe
4. Enregistrer les nouveaux paramètres en appuyant sur ON/Veille (B1)	
	









8. NETTOYAGE DE L'APPAREIL







Attention !

- Pour le nettoyage de la machine, ne pas utiliser de solvants, de nettoyeurs abrasifs ou de l'alcool.
- Ne pas utiliser d'objets métalliques pour retirer les incrustations ou les dépôts de café car ils pourraient rayer les surfaces en métal ou en plastique.
- Pour des périodes d'inutilisation supérieures à 1 semaine il est recommandé, avant d'utiliser la machine, de procéder à un rinçage.

Danger !



- Au cours du nettoyage, ne jamais plonger la machine dans l'eau : c'est un appareil électrique.
- Avant toute opération de nettoyage des parties extérieures de l'appareil, éteindre la machine, retirer la fiche de la prise de courant et laisser refroidir la machine.

					
	×	✓	✓	×	×
	✓	×	×	✓	✓
	×	×	×	✓	✓
	×	×	×	✓	✓
→					

					
	×	×	✓	✓	×
	×	×	×	✓	✓

8.1 Nettoyage de la buse à café



Quand le voyant  s'allume (orange) (B13), il faut procéder au nettoyage du circuit café. Pour effectuer le cycle de nettoyage, acheter les pastilles de nettoyage pour machines à café. Pour de plus amples informations, visiter www.Delonghi.com.

1. Insérer le filtre 1 tasse (C2) dans le porte-filtre (C1) (fig. 25).
2. Insérer l'accessoire de nettoyage (C8) dans le filtre (fig. 25) et le presser à fond.
3. Mettre la pastille pour le nettoyage sur l'accessoire (fig. 26).
4. Accrocher le porte-filtre à la buse à café (A18).
5. Remplir le réservoir d'eau (A14). S'assurer que l'égouttoir (A10) est vide.
6. Maintenir enfoncée la touche  (B6), jusqu'à ce que le voyant  (B13) s'allume. Après quelques minutes, le nettoyage s'interrompt automatiquement.
7. Enlever le porte-filtre et l'accessoire de nettoyage.
8. Laver le porte-filtre et le filtre à l'eau courante.
9. Réinsérer le porte-filtre et procéder à un rinçage en appuyant sur la touche  : on conseille de mettre un récipient sous le porte-filtre.
10. Enlever et vider l'égouttoir.

Nota bene :

Ce cycle de nettoyage peut être lancé à tout moment en appuyant sur la touche  pendant quelques secondes. Pour annuler l'opération, appuyer sur le bouton pendant 10 secondes.

8.2 Nettoyer le logement du réservoir à grains

1. S'assurer que le réservoir à grains (A2) est vide. Éventuellement procéder à quelques moutures à vide pour le vider.
2. Décrocher le réservoir de la machine en le tournant dans le sens inverse des aiguilles d'une montre (fig. 27)
3. Aspirer les résidus de café (fig. 28).
4. Nettoyer le logement du réservoir à grains à l'aide d'un chiffon humide et essuyer (fig. 29) ;
5. Repositionner le réservoir en l'insérant dans le moulin à café. Le réservoir est inséré correctement quand la flèche  est alignée au symbole  et que l'on entend un « clic » (fig.30).

8.3 Nettoyage des meules

Lorsqu'on nettoie le réservoir à grains (A2), nettoyer le logement du réservoir et la meule supérieure à l'aide d'un chiffon humide. S'adresser à un centre d'assistance pour enlever ou remplacer les meules.

Il est possible d'enlever la meule au cas où le moulin à café serait bloqué par un corps étranger. Si c'est le cas, enlever le réservoir à grains et procéder de la manière suivante :

1. Accrocher la coupelle porte-filtre (C1) et faire une mouture « à vide » pour libérer le conduit du café.
2. Éteindre l'appareil.
3. Tourner le régulateur de mouture dans le sens inverse des aiguilles d'une montre jusqu'en butée, sur la position « RE-MOVE » (fig. 31).
4. Extraire la partie supérieure de la meule, en la saisissant par la poignée prévue à cet effet (fig.32).
5. Nettoyer la meule à l'aide d'un pinceau (fig. 33) et aspirer les résidus de café avec un aspirateur (fig. 28).

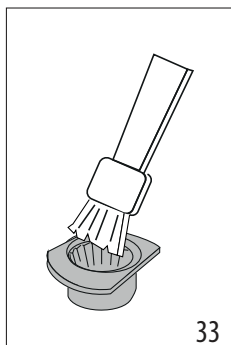

33

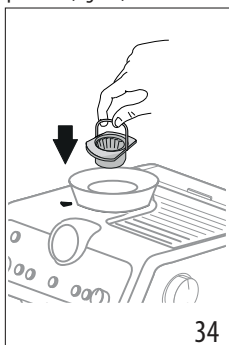

34

6. Insérer la meule dans son logement (fig. 34) ;
7. Tourner le régulateur en sélectionnant le degré de mouture souhaité (fig. 14) ;

Vérifier que la meule est bien insérée, en la tirant par la poignée : la meule est insérée correctement si elle ne bouge pas.

8.4 Remplacement des meules

Quand la quantité de café moulu diminue encore, s'adresser à un centre d'assistance pour remplacer les meules : puis régler à nouveau le moulin à café en entrant dans le menu paramètres (« 7. Menu paramètres ») et en sélectionnant la première plage du réglage extra de la mouture. Puis, tourner le bouton de réglage quantité (B2) sur la position MIN et régler la dose comme à la première utilisation (voir « La « dose parfaite » »).

8.5 Nettoyage de la « Smart tamping station »

1. Nettoyer la zone d'accrochage avec un pinceau (fig. 35).
2. Tirer le levier (A20) jusqu'en butée et nettoyer le tasseur à l'aide d'un pinceau (fig. 36), puis relâcher le levier.

3. En utilisant l'écouvillon (C7), nettoyer la goulotte café (fig. 37).

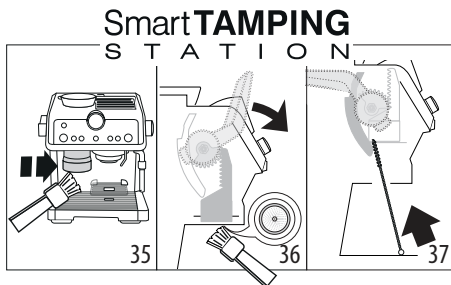

9. DURETÉ DE L'EAU

Le voyant (B9) détartrage s'allume après une période de fonctionnement prédéfinie qui dépend de la dureté de l'eau. Il est possible de programmer la machine en fonction de la dureté réelle de l'eau courante dans les différentes régions, en rendant ainsi l'opération de détartrage moins fréquente.

1. Retirer la bande réactive fournie « TOTAL HARDNESS TEST » (C4) de son emballage.
2. Plonger entièrement la bande réactive dans un verre d'eau pendant environ une seconde.
3. Extraire la bande de l'eau et la secouer légèrement. Programmer l'appareil, comme indiqué dans le chapitre « 7. Menu paramètres ».

Résultat Test Dureté De L'Eau	Touche	Niveau
	×2	1 eau douce
	⚙️	2 eau moyenne
	OK	3 Eau dure ou très dure

4. Programmer l'appareil, comme indiqué dans le chapitre « 7. Menu paramètres ».

10. COMMENT UTILISER SOFTBALLS

Softballs (C9) est un système innovant qui prolonge la durée de vie de la machine, sans altérer la qualité de l'eau, en garantissant la préparation d'un café crémeux et aromatique. Pour optimiser l'efficacité, laisser Softballs dans l'eau pendant toute la nuit précédant l'utilisation.

1. Extraire le paquet de Softballs de l'emballage (fig. 38).

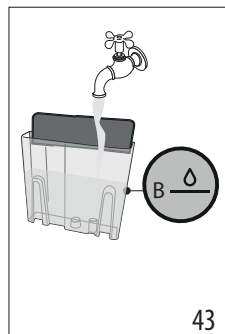
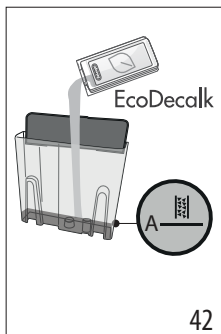
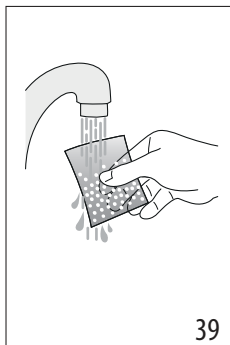
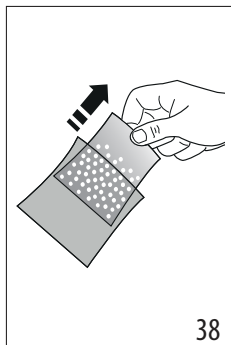

2. Rincer le paquet de Softballs à l'eau courante (fig. 39).
3. Plonger le sachet dans le réservoir d'eau (A14) (fig. 40).

2. Ajouter de l'eau jusqu'au niveau $\underline{\text{B}}$ (fig. 43). Réinsérer donc le réservoir d'eau dans la machine.

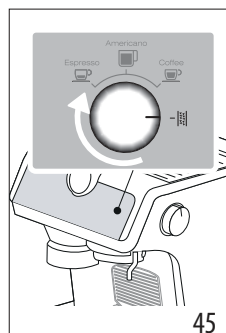
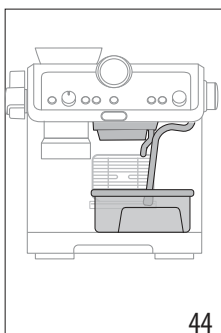
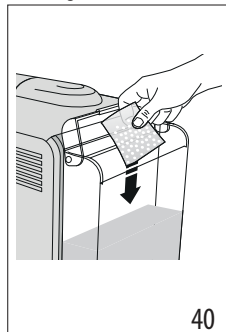



4. Remplacer le sachet de Softballs tous les 3 mois (fig. 41).

3. S'assurer que le porte-filtre (C1) n'est pas accroché et positionner un récipient sous les buses à café, à eau chaude et sous la buse vapeur (A6) (fig. 44).

11. DÉTARTRAGE

Attention !

- Avant l'utilisation, lire les instructions et l'étiquette du détartrant (C5), reportées sur l'emballage du détartrant.
- Il est recommandé d'utiliser exclusivement du détartrant De'Longhi. L'utilisation de détartrants non appropriés, ainsi que le détartrage non régulièrement effectué, peut entraîner l'apparition de défauts non couverts par la garantie du producteur.
- Le détartrant peut abîmer les surfaces délicates. Si le produit est renversé accidentellement, essayer immédiatement.

4. Tourner le bouton (B8) sur  (fig. 45) : le voyant OK s'allume en orange et le voyant  clignote ;
5. Appuyer sur la touche OK : le voyant OK clignote.
6. Le programme de détartrage démarre et le liquide détartrant s'écoule des buses. Le programme de détartrage effectue automatiquement et par intervalles toute une série de rinçages pour enlever les résidus de calcaire qui se trouvent à l'intérieur de la machine à café jusqu'à vider le réservoir.

La distribution s'interrompt et le voyant OK devient blanc. Il est donc nécessaire de procéder au cycle de rinçage :

7. Vider le récipient utilisé pour la récupération du liquide détartrant et le remettre sous les buses.
8. Extraire le réservoir d'eau, le vider d'éventuels résidus de solution détartrante, le rincer à l'eau courante et le remplir d'eau fraîche jusqu'au niveau MAX (fig. 46). Réinsérer donc le réservoir dans son logement.

Pour effectuer le détartrage	
Détartrant	Détartrant De'Longhi
Récipient	Capacité 2 litres
Temps	~40min

1. (SI PRÉSENTS, ENLEVER FILTRE ADOUCISSEUR ET SOFT-BALLS). Verser dans le réservoir d'eau (A14) le détartrant jusqu'au niveau $\underline{\text{A}}$ (correspondant à un emballage de 100ml) imprimé sur le côté interne du réservoir (fig. 42).

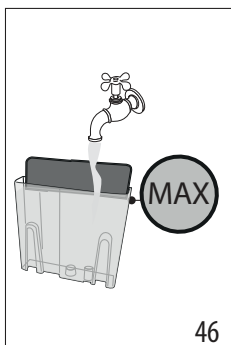















9. Appuyer sur la touche OK : le rinçage démarre.
 10. Une fois le rinçage terminé, la distribution s'interrompt et l'appareil est prêt à l'emploi.
 11. Vider les récipients de récupération de l'eau de rinçage.
 12. Extraire et vider l'égouttoir, puis le réinsérer.
 13. Extraire et remplir le réservoir d'eau fraîche, puis le réinsérer.
- L'appareil est maintenant prêt à l'usage.







Nota bene :



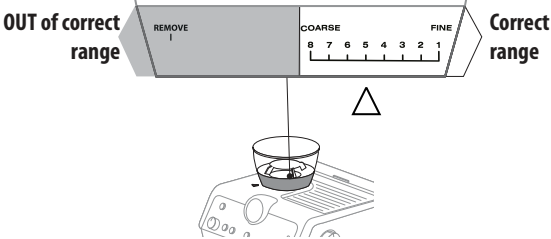

- Le cycle de détartrage peut être lancé à tout moment (même si le voyant correspondant n'est pas encore allumé).
- Au cas où le détartrage aurait été lancé par erreur, appuyer sur la touche OK pendant 10 secondes ; le rinçage ne peut pas être interrompu.

12. SIGNIFICATION DES VOYANTS



VOYANTS	SIGNIFICATION DES VOYANTS	OPÉRATION
Tous les voyants clignotent brièvement	Allumage de l'appareil	Autodiagnostic
 fixe	C'est le premier allumage de la machine et il est nécessaire de procéder au remplissage du circuit eau	Procéder comme indiqué au chap. « 3. Première mise en marche de la machine »
 fixe (blanc) <ul style="list-style-type: none"> • Voyant  : indique la température café sélectionnée • Voyant  : indique que la machine est prête à distribuer de l'eau chaude 	La machine est prête pour la distribution	Préparer la machine et procéder à la préparation de la boisson
 fixe	La fonction économie d'énergie est activée	Se référer au chap. « 7. Menu paramètres » si l'on souhaite désactiver la fonction
 fixe	Le réservoir à grains (A2) est vide	Remplir le réservoir à grains
 clignotant	On souhaite procéder à la mouture, mais le réservoir à grains (A2) est vide	Remplir le réservoir à grains
 clignote brièvement à intervalles réguliers	Le bouton (B2) est tourné sur la position de réglage maximale 	Quand, après la mouture, le café dans le filtre est insuffisant, sélectionner une nouvelle plage de mouture comme indiqué dans le chapitre « 7. Menu paramètres ».
 fixe	L'eau dans le réservoir (A14) n'est pas suffisante ou le réservoir d'eau n'est pas bien inséré	Remplir le réservoir ou extraire et réinsérer correctement le réservoir
		→

VOYANTS	SIGNIFICATION DES VOYANTS	OPÉRATION
 clignotant	On souhaite procéder à la préparation d'une boisson, mais le réservoir d'eau (A14) est vide	Remplir le réservoir d'eau
	La mouture est trop fine et le café sort par conséquent trop lentement ou ne sort pas du tout	Extraire la coupelle porte-filtre (C1), répéter les opérations pour faire le café en tenant compte des indications du par. « 4.1 Phase 1 - Mouture (grinding) » et « 4.2 Phase 2 - Tassage (tamping) »
	Le filtre café (C2) ou (C3) est bouché	Rincer les filtres à l'eau courante
	Le réservoir (A14) est mal inséré et les clapets correspondants ne sont pas ouverts	Presser légèrement le réservoir de manière à en ouvrir les clapets
	Calcaire à l'intérieur du circuit hydraulique	Effectuer le détartrage comme au chap. « 11. Détartrage »
 fixe	L'appareil est prêt pour la distribution de vapeur	L'appareil a atteint la température pour distribuer de la vapeur. Pour procéder à la distribution, tourner le bouton vapeur (A4)
 clignotant	L'appareil est allumé et la fonction économie d'énergie est activée : la manette vapeur (A4) est en position pour distribuer de la vapeur	Le voyant clignote pour indiquer que l'appareil est en train de se préparer pour distribuer de la vapeur : la distribution commence dès que l'appareil est en température
	L'appareil est prêt pour la distribution de vapeur	L'appareil est à la bonne température pour la préparation de vapeur lorsque le voyant reste fixe
	L'appareil est en train de distribuer de la vapeur	
 fixe	Le réservoir à grains n'est pas inséré	Insérer correctement le réservoir à grains (A2) ou vérifier qu'il est inséré correctement. Le réservoir est inséré correctement quand la flèche ▲ est alignée au symbole  et que l'on entend un « clic »
		→

VOYANTS	SIGNIFICATION DES VOYANTS	OPÉRATION
 clignotant	<p>Le réglage du sélecteur du degré de mouture n'est pas correct ou dépasse le réglage maximal possible</p>	<p>Remettre le sélecteur sur l'une des positions de mouture (entre 1 et 8), en se souvenant de :</p> <ul style="list-style-type: none"> • Régler la mouture alors que le moulin à café est en marche • Régler d'un niveau à la fois et faire au moins 5 moutures entre un réglage et l'autre
		<p>OUT of correct range Correct range</p>
 fixe	<p>L'appareil requiert le tassage</p>	<p>La mouture vient d'être effectuée et le porte-filtre est accroché au moulin à café</p>
	<p>Le porte-filtre a été décroché du moulin à café sans tasser</p>	<p>Décrocher le porte-filtre et tasser le café comme décrit au par. « La « dose parfaite » » « Si l'on utilise du café prémoulu : »</p>
	<p>Le porte-filtre a été décroché sans terminer la mouture ou le tassage a été effectué trop vite</p>	<p>Répéter la mouture</p>
	<p>La goulotte café du moulin à café est engorgée</p>	<p>Effectuer le nettoyage en suivant les instructions du par. « 8.5 Nettoyage de la « Smart tamping station » ». Si le problème persiste, accéder à la goulotte en ouvrant le volet prévu à cet effet et la libérer en utilisant l'écouvillon</p>
	<p>Les meules sont bloquées par un corps étranger</p>	<p>Enlever le corps étranger et nettoyer les meules comme indiqué au par. « 8.3 Nettoyage des meules ».</p>
 fixe (rouge)	<p>Il est nécessaire de procéder au détartrage</p>	<p>Effectuer le détartrage comme illustré au chap. « 11. Détartrage »</p>
 clignote (rouge) +  OK clignote (orange)	<p>L'appareil est en train d'effectuer le détartrage</p>	<p>Compléter l'opération comme décrit au chap. « 11. Détartrage »</p>
 clignote (rouge) +  OK fixe (blanc)	<p>Il faut procéder au rinçage</p>	
→		

VOYANTS	SIGNIFICATION DES VOYANTS	OPÉRATION
 clignote (rouge) +  clignote (blanc)	L'appareil est en train d'effectuer le rinçage du cycle détartrage	
 fixe (orange)	Il faut procéder au nettoyage de la buse à café	Voir par. « 8.1 Nettoyage de la buse à café »
 clignotant (orange)	L'appareil est en train d'effectuer le nettoyage de la buse à café	
Tous les voyants clignent	EN DEHORS de la plage nt	S'adresser à un centre d'a Plage correcte

13. SI QUELQUE CHOSE NE FONCTI **correcte**

PROBLÈME	CAUSE	SOLUTION
Il y a de l'eau dans l'égouttoir (A10)	Cela fait partie du fonctionnement normal des circuits internes de la machine	Vider et nettoyer régulièrement l'égouttoir
Le café espresso ne sort plus	Absence d'eau dans le réservoir (A14)	Remplir le réservoir
	Le voyant  (B6) est allumé et indique que le circuit café ou le circuit vapeur est vide	Appuyer sur la touche correspondante au voyant  pour remplir le circuit
	Le filtre (C2) ou (C3) est bouché	Rincer les filtres à l'eau courante
	Le réservoir (A14) est mal inséré et les clapets sur le fond ne sont pas ouverts	Enfoncer légèrement le réservoir pour ouvrir les clapets sur le fond
	Calcaire à l'intérieur du circuit hydraulique	Effectuer le détartrage comme au chap. « 11. Détartrage »
	Mouture trop fine	Extraire la coupelle porte-filtre (C1), répéter les opérations pour faire le café en tenant compte des indications du par. « 4.1 Phase 1 - Mouture (grinding) » et « 4.2 Phase 2 - Tassage (tamping) »
Le porte-filtre ne s'accroche pas à l'appareil	Le café moulu n'a pas été tassé ou est en quantité excessive	Répéter la mouture avec des paramètres différents. Réduire la quantité de la dose : vérifier que le filtre (C2) ou (C3) (1 ou 2 tasses) est correct par rapport à la dose à moudre (touche 2x (B3) sélectionnée ou non sélectionnée)
Le café espresso goutte sur les bords du porte-filtre (C1) et non des orifices	Le porte-filtre est mal inséré	Fixer correctement le porte-filtre et le tourner à fond avec force
	Le joint de la buse à café (A18) n'est plus élastique ou est sale	Remplacer le joint de la buse à café auprès d'un Centre d'Assistance
	Le filtre (C2) ou (C3) est bouché	Rincer les filtres à l'eau courante
		→

PROBLÈME	CAUSE	SOLUTION
La crème du café est claire (le café sort rapidement du bec)	Il faut revoir les paramètres de l'appareil	Extraire la coupelle, répéter les opérations pour faire le café en tenant compte des indications du par. « 4.1 Phase 1 - Mouture (grinding) » et « 4.2 Phase 2 - Tassage (tamping) »
La crème du café est foncée (le café sort lentement du bec)	Il faut revoir les paramètres de l'appareil	Extraire la coupelle porte-filtre (C1), répéter les opérations pour faire le café en tenant compte des indications du par. « 4.1 Phase 1 - Mouture (grinding) » et « 4.2 Phase 2 - Tassage (tamping) »
Au terme du détartrage, l'appareil a besoin d'un autre rinçage	Durant le cycle de rinçage, le réservoir n'a pas été rempli jusqu'au niveau MAX	Répéter le rinçage (voir chap. « 11. Détartrage »)
L'appareil ne moule pas le café	Un corps étranger est présent à l'intérieur du moulin à café	Effectuer le nettoyage des meules en suivant les instructions du par. « 8.3 Nettoyage des meules », en s'assurant d'avoir enlevé tous les grains du réservoir à grains (A2) avant de l'extraire. Avant de réinsérer la meule, aspirer soigneusement chaque résidu de son logement
	Le réservoir à grains (A2) n'est pas dans la position correcte	Le réservoir est inséré correctement quand la flèche ▲ est alignée au symbole  et que l'on entend un « clic »
Si l'on souhaite changer de qualité de café	Il est nécessaire d'éliminer tous les grains présents dans la machine	<ul style="list-style-type: none"> • Vider le réservoir à grains (A2) (en faisant des moutures à vide ou éventuellement en aspirant les grains résiduels) • Accrocher la coupelle porte-filtre (C1) et faire des moutures « à vide » pour libérer le conduit du café : accrocher le porte-filtre à la sortie du moulin à café (A19) en l'alignant à l'inscription INSERT et tourner la coupelle vers la droite. La mouture commence lorsque la coupelle atteint la position CLOSE et s'interrompt automatiquement. Répéter jusqu'à ce que le filtre soit vide • Insérer la nouvelle variété de grains de café dans le réservoir (A2) • Si la « dose parfaite » n'est pas atteinte lors de la mouture, procéder comme à la première utilisation
		→

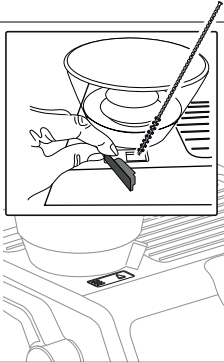
PROBLÈME	CAUSE	SOLUTION
<p>Après la mouture, le filtre café (C2) ou (C3) est vide</p> <p>Après la mouture, la poudre de café dans le filtre est surabondante</p>	<p>La goulotte café du moulin à café est engorgée</p>	<p>Effectuer le nettoyage en suivant les instructions du par. « 8.5 Nettoyage de la « Smart tamping station » ». Si le problème persiste, accéder à la goulotte en ouvrant le volet (A21) prévu à cet effet et la libérer en utilisant l'écouvillon</p> 
<p>Après la mouture, la poudre de café dans le filtre (C2) ou (C3) n'atteint pas la « dose parfaite »</p>	<p>La « Smart Tamping Station » a besoin d'être nettoyée</p> <p>Il faut régler la quantité de café moulu</p> <p>Avec le temps les meules s'usent</p>	<p>Effectuer le nettoyage en suivant les instructions du par. « 8.5 Nettoyage de la « Smart tamping station » », puis répéter la mouture</p> <p>Régler la quantité à l'aide du bouton dédié (B2) en suivant les indications du par. « La « dose parfaite » ». Si le bouton est déjà sur la position max, procéder comme indiqué à la section « 7. Menu paramètres » - « Réglage extra de la mouture »</p> <p>Procéder au remplacement des meules comme indiqué au par. « 8.4 Remplacement des meules »</p>

Vor dem Gebrauch des Gerätes lesen Sie bitte immer das Heft mit den Sicherheitshinweisen durch.

1. BESCHREIBUNG

1.1 Beschreibung des Gerätes - A

- A1. Deckel des Kaffeebohnenbehälters
- A2. Kaffeebohnenbehälter
- A3. Tassenrost
- A4. Ausgabeknopf für Dampf
- A5. Heißwasserauslauf
- A6. Dampfausgaberohr
- A7. Tassenrost für Espresso
- A8. Tassenrost für Gläser oder große Tassen
- A9. Rost der Abtropfschale
- A10. Abtropfschale
- A11. Wasserstandsanzeige in der Abtropfschale
- A12. Deckel des Wassertanks
- A13. Griff zur Entnahme des Wassertanks
- A14. Wassertank
- A15. Aufnahme für Wasserfilter
- A16. Aufnahme Steckverbindung Netzkabel
- A17. Hauptschalter (ON/OFF)
- A18. Kaffeeauslauf
- A19. Mahlwerkzugang (Tamperstation)
- A20. Anpresshebel
- A21. Tür für den Zugang zur Rutsche des Mahlwerks

1.2 Beschreibung der Bedienblende - B

- B1. Taste ON/Bereitschaft
- B2. Mengenregler für Kaffeepulver
- B3. Taste „X2“: zur Verwendung des Siebs für 2 Kaffees
- B4. Taste „Kaffeetemperatur“
- B5. Taste „OK“: zur Ausgabe des Getränks/Bestätigung
- B6. Taste „Heißwasserausgabe“
- B7. Taste „My“: zur individuellen Einstellung der Menge des Getränks
- B8. Funktionswahlschalter
 - Espresso
 - Americano
 - Kaffee
 - Entkalkung
- B9. Kontrolllampe „Entkalkung“
- B10. Kontrolllampe „Dampf bereit“
- B11. Kontrolllampe „Kaffeebohnenbehälter fehlt“
- B12. Kontrolllampe „Energiesparmodus“
- B13. Kontrolllampe „Reinigung“ (siehe „8.1 Cleaning of the coffee outlet“)
- B14. Kontrolllampe „Kaffeebohnenbehälter leer“
- B15. Kontrolllampe „Wasser fehlt“
- B16. Kontrolllampe „Anpressen“
- B17. Manometer

1.3 Beschreibung der Zubehörteile - C

- C1. Siebträger
- C2. 1-Tassen-Sieb
- C3. 2-Tassen-Sieb
- C4. Reaktionsstreifen „Total Hardness Test“
- C5. Entkalker
- C6. Abnehmbares Netzkabel
- C7. Bürste
- C8. Reinigungszubehör für Kaffeeauslauf
- C9. Softballs
- C10. Milchkännchen
- C11. Reinigungsnadel für Dampfzange

1.4 Vom Hersteller empfohlenes, nicht im Lieferumfang enthaltenes Reinigungszubehör

Für weitere Informationen besuchen Sie bitte Delonghi.com.



Reinigungstabs

(Siehe „8.1 Reinigung des Kaffeeauslaufs“)

 **Reinigungsmittel**
EAN: 8004399333307

2. VORBEREITUNG DES GERÄTES

Reinigen Sie alle Zubehörteile mit lauwarmem Wasser und Geschirrspülmittel und fahren Sie dann wie folgt fort:

1. Setzen Sie den Kaffeebohnenbehälter (A2) in das Mahlwerk ein (Abb. 1). Der Behälter ist richtig eingesetzt, wenn der Pfeil ▲ mit dem Symbol ☐ übereinstimmt und ein „Klicken“ zu hören ist (Abb. 2).
2. Setzen Sie die Abtropfschale (A10) zusammen mit dem Tassenrost (A8) und dem Rost der Abtropfschale (A9) ein (Abb. 3);
3. Nehmen Sie den Wassertank heraus (A14) (Abb. 4) und füllen Sie ihn mit frischem, sauberem Wasser, wobei darauf zu achten ist, dass die Markierung MAX nicht überschritten wird (Abb. 5).
4. Setzen Sie dann den Wassertank wieder ein.

Vorsicht: Das Gerät nie mit leerem Wassertank oder ohne Wassertank in Betrieb setzen.

Hinweis: Wir empfehlen Ihnen, die Wasserhärte so bald wie möglich je nach individuellem Bedarf einzustellen, indem Sie, wie in Kapitel „7. Menü Einstellungen“ beschrieben, vorgehen.

3. ERSTE INBETRIEBNAHME DES GERÄTES

1. Stecken Sie die Steckverbindung des Netzkabels (C6) in ihre Aufnahme (A16) an der Rückseite des Gerätes (Abb. 6); stecken Sie dann den Stecker in die Steckdose. Stellen Sie sicher, dass der Hauptschalter (A17) an der Rückseite des Gerätes auf I steht (Abb. 7);

2. Stellen Sie einen Behälter mit einem Mindestfassungsvermögen von 100 ml unter den Heißwasserauslauf (in Höhe des Kaffeeauslaufs (A18)) (Abb. 8);
3. Drücken Sie die Taste (B6) für die Kontrolllampe (☺) (Abb. 9): die Ausgabe beginnt und wird automatisch abgebrochen. Leeren Sie den Behälter.

Vor dem ersten Gebrauch der Kaffeemaschine müssen die internen Leitungen der Kaffeemaschine durchgespült werden. Dazu wie folgt vorgehen:

4. Rasten Sie den Siebträger (C1) mit dem Sieb an der Kaffeemaschine ein: zum richtigen Einrasten muss der Griff des Siebträgers auf „INSERT“ (Abb. 10) ausgerichtet und der Handgriff nach rechts gedreht werden, bis er mit der Position „CLOSE“ übereinstimmt;
5. Stellen Sie einen Behälter unter den Siebträger und das Dampfausgaberohr (A6);
6. Drücken Sie die Taste OK (B5) (Abb. 11): die Ausgabe beginnt;
7. Drehen Sie nach Beendigung der Ausgabe den Ausgabeknopf für Dampf (A4) (Abb. 12) und geben Sie für einige Sekunden Dampf aus, um den Dampfkreislauf durchzuspülen: für eine optimale Dampfausgabe wird empfohlen, diesen Vorgang drei- oder viermal zu wiederholen. Dadurch wird vor der Dampfausgabe das Wasser im Rohr beseitigt.

Danach ist das Gerät betriebsbereit.

Hinweis: das Spülen der internen Leitungen wird auch bei längerem Nichtgebrauch des Gerätes empfohlen.

Beim ersten Gebrauch müssen Sie mindestens 4-5 Kaffees zubereiten, bevor die Kaffeemaschine ein zufriedenstellendes Resultat erzielt: achten Sie besonders auf die in das Sieb ((C2) oder (C3)) gemahlene Kaffeemenge (siehe Anleitung im Abschnitt „4.1 Schritt 1 - Mahlvorgang (grinding)“).

Gemäß den Angaben im Kapitel „Die „perfekte Menge““ vorgehen.

4. ZUBEREITUNG VON KAFFEE

4.1 Schritt 1 - Mahlvorgang (grinding)

1. Füllen Sie die Bohnen in den Behälter (A2) (Abb. 13). Es ist empfehlenswert, nur die für die Zubereitung benötigten Bohnen einzufüllen: auf diese Weise ist der Kaffee bei der Verwendung immer frisch;
2. Mahlgrad einstellen (Abb. 14). Die werkseitige Einstellung ist 5 (mittlerer Mahlgrad). Sollte das Resultat nicht zufriedenstellend sein, kann die Stufe anhand des eigenen Geschmacks und der Kaffeesorte eingestellt werden (Einstellung muss bei laufendem Mahlwerk erfolgen).

Hinweis: Der Mahlgrad zwischen 3 und 6 wird für die meisten Kaffees empfohlen. Bei der Einstellung des Mahlgrads auf 1 oder 2 ist das Resultat sehr fein; sie sollte daher nur bei sehr speziellen Kaffees verwendet werden (leicht geröstet).

3. Setzen Sie eines der Kaffeesiebe (C2) oder (C3) in den Siebträger (C1) ein (Abb. 15). Wenn das Sieb für 2 Tassen verwendet wird, muss die Taste X2 (B3) gedrückt werden: bei dieser Auswahl wird auch die doppelte Menge Espresso ausgegeben.

4. Regeln Sie den Drehknopf zur Auswahl der Menge (B2), indem Sie auf kleinster Stufe beginnen (Abb. 16).

Für weitere Angaben wird auf den Abschnitt „Die in das Sieb gemahlene Kaffeemenge einstellen“ verwiesen.

5. Rasten Sie den Siebträger am Ausgang des Mahlwerks (A19) ein und richten Sie ihn zum Text INSERT aus: drehen Sie dann den Siebträger nach rechts. Der Mahlvorgang beginnt, wenn der Siebträger die Position CLOSE erreicht und wird automatisch abgebrochen.

Die in das Sieb gemahlene Kaffeemenge einstellen

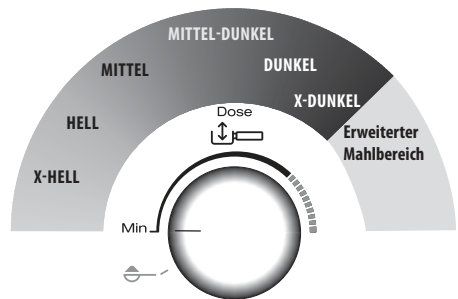

Jede Kaffeebohensorte erzielt ein anderes Mahlergebnis; die Einstellung der Menge muss daher zu Beginn sehr sorgfältig erfolgen.

Diese Erläuterung gibt Hinweise zur Einstellung der Menge, die auf der Röstfarbe basieren: sie sind als Ausgangspunkt zu verstehen, können aber anhand der Zusammensetzung der Kaffeebohnen variieren.

1. Stellen Sie die Menge der kleinsten Position ein.
2. Drehen Sie den Drehknopf langsam unter Berücksichtigung der Röstfarbe Ihres Kaffees.

4.2 Schritt 2 - Anpressen (tamping)

1. Drücken Sie nach dem Mahlvorgang den Anpresshebel (A20) bis zum Anschlag nach unten (entfernen Sie den Siebträger nicht) (Abb. 17). Für ein perfektes Resultat muss der Vorgang zweimal wiederholt werden.
2. Halten Sie den Hebel beim Entfernen des Siebträgers bis zum Anschlag nach unten gedrückt (Abb. 18). Bringen Sie den Hebel dann wieder in die Ausgangsstellung zurück.
3. Rasten Sie den Siebträger, nachdem sie geprüft haben, dass die Kaffeemenge korrekt ist (siehe „Die „perfekte Menge““, am Kaffeeauslauf ein (A18) (Abb. 19).

Hinweis: Wenn nach dem Anpressen Kaffeerückstände an den Rändern des Siebs verbleiben, beeinträchtigt dies in keiner Weise die Qualität der Extraktion und des Endresultats.

Die „perfekte Menge“

- Die Kaffeesiebe haben innen eine Markierung für die Anzeige der perfekten Menge.



- Siebe mit Lasermarkierung: die perfekte Menge entspricht der oberen Linie der Markierung;
 - Siebe mit erhabener Markierung: die perfekte Menge entspricht der erhabenen Linie;
- Vergewissern Sie sich, dass sich der Kaffee nach dem Anpressen in diesem Bereich befindet. Es könnte notwendig sein, den Drehknopf (B2) mehrfach zu regeln, bevor die perfekte Menge erreicht ist.
 - Wenn der Kaffee über- oder unterextrahiert ist und sich die Dosierung im Bereich der perfekten Menge befindet, muss der Mahlgrad feiner oder gröber eingestellt werden (siehe „4.1 Schritt 1 - Mahlvorgang (grinding)“). Wenn der Kaffee überextrahiert ist (Ausgabe zu langsam), muss der Mahlgrad gröber eingestellt werden. Wenn der Kaffee unterextrahiert ist (Ausgabe zu schnell), muss der Mahlgrad feiner eingestellt werden.
 - Der Barista empfiehlt:** Nehmen Sie den Siebträger (A20) heraus während der Anpresshebel nach unten gedrückt ist, um das Kaffeepulver perfekt gleichmäßig zu verteilen.
 - Wenn vorgemahlener Kaffee verwendet wird:**
 - geben Sie den vorgemahlene Kaffee in das Sieb;
 - drehen Sie den Drehknopf auf ;
 - rasten Sie den Siebträger am Ausgang des Mahlwerks ein;
 - drücken Sie den Anpresshebel nach unten.

4.3 Schritt 3 - Ausgabe (brewing)

- Wählen Sie die Temperatur (Abb. 20) (siehe „Temperatur für die Kaffeezubereitung“).
- Wählen Sie das gewünschte Getränk (Abb. 21).
- Drücken Sie OK (B5), um mit der Ausgabe zu beginnen (Abb. 11) (Vorbrühen und Brühen). Die Kaffeeausgabe wird automatisch abgebrochen.

Temperatur für die Kaffeezubereitung

Die Wassertemperatur ist während des gesamten Zubereitungsprozesses kontrolliert, um ihre Stabilität in der Extraktionsphase zu gewährleisten. Die Specialista Prestigio bietet 3 Brühtemperaturen*, die einem Bereich zwischen 92°C und 96°C entsprechen.

Je nach Sorte und Röstgrad der Bohnen wird eine unterschiedliche Temperatur empfohlen: Robusta-Bohnen erfordern eine niedrige Temperatur; Arabica-Bohnen eine hohe Temperatur. Das gleiche gilt für Bohnen mit dunkler Röstung oder für frisch geröstete Bohnen.

Temperaturstufe	Entsprechende Kontrolllampe	Röstgrad
MIN		Dunkel
MED		Mittel-dunkel
MAX		Hell - Mittel

- * Diese Temperatur bezieht sich auf das Wasser im Thermoblock. Sie weicht daher von der Temperatur des Getränks in der Tasse oder von der beim Austreten des Getränks aus den Ausläufen des Siebträgers gemessenen Temperatur ab.

5. ZUBEREITUNG VON MILCHGETRÄNKEN

5.1 Milch aufschäumen

- Füllen Sie das Kännchen (C10) mit der Milchmenge, die erhitzt/aufgeschäumt werden soll; beachten Sie dabei, dass sich das Milchvolumen verdoppelt bis verdreifacht (Abb. 22). Um einen üppigeren und gleichmäßigeren Schaum zu erhalten, verwenden Sie Kuhvollmilch mit Kühlschranktemperatur (etwa 5°C).

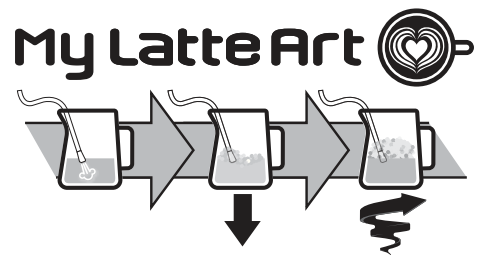

- Um die Milch aufzuschäumen, legen Sie das Dampfausgaberohr (A6) auf die Milchoberfläche: so vermischt sich die Luft mit der Milch und dem Dampf.
- Halten Sie das Dampfausgaberohr auf der Oberfläche und achten Sie darauf, dass nicht zu viel Luft aufgenommen wird und sich nicht zu große Blasen bilden.
- Tauchen Sie das Dampfausgaberohr unter die Milchoberfläche: auf diese Weise entsteht ein Wirbel. Sobald die

gewünschte Temperatur erreicht ist, schließen Sie den Ausgabeknopf für Dampf wieder und warten, bis die Dampfabgabe vollständig beendet ist, bevor Sie das Milchkännchen entnehmen.

Der Barista empfiehlt:

- **Frische Milch ist besser.** Verwenden Sie immer Milch mit Kühlschranktemperatur.
- Für ein besseres Resultat wird empfohlen, das Milchkännchen immer in den Kühlschrank zu stellen.
- Vollmilch bietet ausgezeichnete Resultate. Das Resultat und die Textur des Schaums variieren, je nachdem, ob Kuhmilch oder pflanzliche Getränke verwendet werden.
- Schwenken Sie das Milchkännchen nach dem Aufschäumen leicht, damit die Blasen aufplatzen.

Reinigung des Dampfausgaberohrs:

1. Entfernen Sie nach jedem Gebrauch die Milchrückstände mit einem weichen Tuch vom Dampfausgaberohr (Abb. 23). Für eine gründliche Reinigung ist die Verwendung von Eco MultiClean empfehlenswert: es garantiert Hygiene, da Milcheiweiße und Milchfette beseitigt werden, und kann für die Reinigung der gesamten Kaffeemaschine verwendet werden.
2. Geben Sie für einige Sekunden Dampf aus, um das Ausgaberohr gut zu reinigen (Abb. 12).
3. Warten Sie, bis der Auslauf abgekühlt ist: verwenden Sie die Reinigungsnadel (C11), um die 3 Löcher frei zu halten (Abb. 24), damit das Ausgaberohr langfristig funktions-tüchtig bleibt.

6. INDIVIDUELLE EINSTELLUNG DER MENGE DER KAFFEEGETRÄNKE MIT DER TASTE (my) (B7)

1. Bereiten Sie die Kaffeemaschine vor, um 1 oder 2 Tassen des gewünschten Kaffeegetränks auszugeben, und rasten Sie den Siebträger (C1) mit Sieb (C2) oder (C3) und mit Kaffepulver ein.
2. Drehen Sie den Drehknopf (B8), um das Getränk auszuwählen, das programmiert werden soll.
3. Drücken Sie die Taste (my): die Kontrolllampe für die Taste (my) blinkt.
4. Drücken Sie die Taste OK, um mit der Ausgabe zu beginnen. Die Kontrolllampen für die Tasten OK und (my) blinken.
5. Sobald die gewünschte Menge erreicht ist, drücken Sie OK. Falls das Getränk die Ausgabe einer weiteren Zutat vorsieht, beginnt deren Ausgabe: sobald die gewünschte Menge erreicht ist, drücken Sie OK.
6. Drücken Sie die Taste (my), um zu speichern. Das Gerät ist für einen neuen Gebrauch bereit und die Kontrolllampe (my) bleibt eingeschaltet.

Wenn die Programmierung nicht gespeichert werden soll, drücken Sie eine beliebige andere Taste.

Hinweis:

- Kaffeegetränke können programmiert werden, nicht aber die Dampfabgabe und die Heißwasserausgabe.
- Die Programmierung ändert die Mengen der Getränke, aber nicht die Menge des gemahlene Kaffees.
- Die Getränke „X2“ können separat programmiert werden.
- **Um zu den Werkseinstellungen zurückzukehren, halten Sie die Taste (my) bis zur Ausschaltung anhaltend gedrückt.** Das gewählte Getränk kehrt auf die Werkseinstellung zurück.

Kaffeeerzept	Werkseinstellung	Programmierbare Menge
Espresso	35 ml	25 bis 90 ml
Espresso X2	70 ml	50 bis 180 ml
Coffee	80 ml	50 bis 120 ml
Coffee X2	160 ml	120 bis 240 ml
Americano	120 ml	• Espresso: 25 bis 60 ml • Wasser: 25 bis 120 ml
Americano X2	240 ml	• Espresso: 50 bis 120 ml • Wasser: 50 bis 240 ml

7. MENÜ EINSTELLUNGEN



1. Das Menü aufrufen:

Drücken Sie gleichzeitig für 5 Sekunden	x2	
---	----	--





2. Einstellungen mit Auswahl über den Drehknopf (B8)

Entsprechende Einstellung	Drehen auf	Regelungen
Erweiterte Einstellung des Mahlgrads	Espresso 	x2 → Bereich 1
		☰ → Bereich 2

→

Wasserhärte	 Americano	×2 → weich
		≡ → mittel
		OK → hart/sehr hart
Auto-Abschaltung	 Coffee	×2 → 9 Minuten
		≡ → 1,5 Stunden
		OK → 3 Stunden

3. Einstellungen mit Auswahl über die Taste:

Energiesparmodus	 → Aktiv
	 →  Ausgeschaltet
Werkseinstellungen	Halten Sie die Taste  für mindestens 5 Sekunden gedrückt, bis die Kontrolllampe permanent eingeschaltet bleibt

4. Speichern Sie die neuen Einstellungen durch Drücken von ON/Bereitschaft (B1)

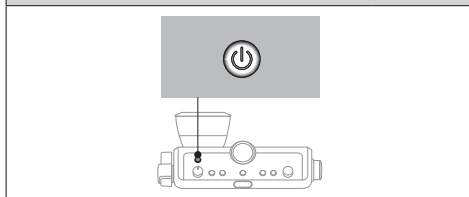











8. REINIGUNG DES GERÄTES

Vorsicht!

- Verwenden Sie zur Reinigung der Maschine keine Lösungsmittel oder Scheuermittel oder Alkohol.
- Verwenden Sie zum Entfernen von Verkrustungen oder Kaffeeablagerungen keine Metallgegenstände, weil sie Oberflächen aus Metall oder Kunststoff verkratzen könnten.
- Bei Nichtgebrauch von mehr als einer Woche wird empfohlen, vor dem Gebrauch der Kaffeemaschine einen Spülvorgang durchzuführen.



Gefahr!

- Während der Reinigung die Kaffeemaschine nie ins Wasser tauchen: es handelt sich um ein Elektrogerät.
- Vor jeder Reinigung der äußeren Teile des Gerätes die Kaffeemaschine ausschalten, den Netzstecker aus der Steckdose ziehen und die Kaffeemaschine abkühlen lassen.

					
	×	✓	✓	×	×
	✓	×	×	✓	✓
	×	×	×	✓	✓
	×	×	×	✓	✓
	×	×	✓	✓	×
	×	×	×	✓	✓

8.1 Reinigung des Kaffeeauslaufs



Wenn die Kontrolllampe  sich einschaltet (orange) (B13), muss der Kaffeeauslauf gereinigt werden. Kaufen Sie die Reinigungstabs für Kaffeemaschinen, um den Reinigungszyklus durchzuführen. Für weitere Informationen besuchen Sie bitte www.Delonghi.com.

1. Setzen Sie das 1-Tassen-Sieb (C2) in den Siebträger (C1) (Abb. 25).
2. Setzen Sie das Reinigungszubehör (C8) in das Sieb (Abb. 25) und drücken Sie es fest nach unten.
3. Legen Sie den Reinigungstab auf das Zubehör (Abb. 26).
4. Rasten Sie den Siebträger am Kaffeeauslauf (A18) ein.
5. Füllen Sie den Wassertank (A14). Vergewissern Sie sich, dass die Abtropfschale (A10) leer ist.
6. Halten Sie die Taste  (B6) gedrückt, bis sich die Kontrolllampe  (B13) einschaltet. Nach einigen Minuten wird die Reinigung automatisch abgebrochen.
7. Entnehmen Sie den Siebträger und das Reinigungszubehör.
8. Waschen Sie den Siebträger und das Sieb unter fließendem Wasser.
9. Setzen Sie den Siebträger wieder ein und führen Sie einen Spülvorgang durch, indem Sie die Taste  drücken: es wird empfohlen, einen Behälter unter den Siebträger zu stellen.
10. Nehmen Sie die Abtropfschale heraus und leeren Sie sie.

Hinweis:

Dieser Reinigungszyklus kann jederzeit gestartet werden, indem die Taste  für einige Sekunden gedrückt wird. Um den Vorgang abzubrechen, drücken Sie die Taste für 10 Sekunden.

8.2 Reinigen Sie das Fach des Kaffeebohnenbehälters

1. Vergewissern Sie sich, dass der Kaffeebohnenbehälter (A2) leer ist. Lassen Sie das Mahlwerk eventuell einige Male leer laufen, um es zu leeren.
2. Rasten Sie den Kaffeebohnenbehälter aus, indem Sie ihn nach links drehen, und ziehen Sie ihn aus der Kaffeemaschine (Abb. 27).
3. Saugen Sie Kaffeerückstände auf (Abb. 28).
4. Reinigen Sie die Aufnahme des Kaffeebohnenbehälters mit einem feuchten Tuch und trocknen Sie sie ab (Abb. 29);
5. Setzen Sie den Kaffeebohnenbehälter wieder in das Mahlwerk ein. Der Behälter ist richtig eingesetzt, wenn der Pfeil  mit dem Symbol  übereinstimmt und ein „Klicken“ zu hören ist (Abb. 30).

8.3 Reinigung der Mahlwerkzeuge

Wenn der Kaffeebohnenbehälter (A2) gereinigt wird, müssen auch die Aufnahme des Behälters und das obere Mahlwerkzeug mit einem feuchten Tuch gereinigt werden. Wenden Sie sich an ein Kundendienstzentrum, um die Mahlwerkzeuge zu entfernen und auszutauschen.

Das Mahlwerkzeug kann entfernt werden, wenn das Mahlwerk durch einen Fremdkörper blockiert ist. Sollte dies passieren, entfernen Sie den Kaffeebohnenbehälter und gehen Sie wie folgt vor:

1. Rasten Sie den Siebträger (C1) ein und lassen Sie das Mahlwerk einmal „leer“ laufen, um den Kaffeeschacht zu befreien.
2. Schalten Sie das Gerät aus.
3. Drehen Sie den Mahlgradregler bis zum Anschlag nach links auf die Position „REMOVE“ (Abb. 31).
4. Ziehen Sie den oberen Teil des Mahlwerkzeugs an seinem Griff heraus (Abb. 32).
5. Reinigen Sie das Mahlwerkzeug mit einem Pinsel (Abb. 33) und saugen Sie Kaffeerückstände mit einem Staubsauger auf (Abb. 28).

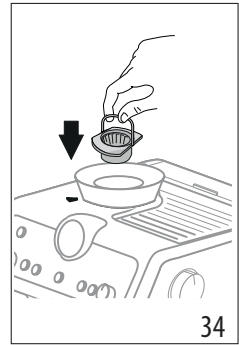
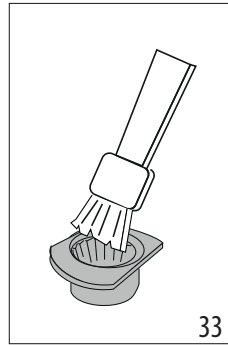

6. Setzen Sie das Mahlwerkzeug in seine Aufnahme (Abb. 34);
7. Drehen Sie den Regler auf den gewünschten Mahlgrad (Abb. 14);

Überprüfen Sie, ob das Mahlwerkzeug richtig eingesetzt ist, indem Sie am Griff ziehen: das Mahlwerkzeug ist richtig eingesetzt, wenn es sich nicht bewegt.

8.4 Austauschen der Mahlwerkzeuge

Wenn sich die Kaffeepulvermenge weiterhin reduziert, wenden Sie sich an ein Kundendienstzentrum, um die Mahlwerkzeuge auszutauschen: stellen Sie dann das Mahlwerk erneut ein, indem Sie das Menü Einstellungen („7. Menü Einstellungen“) aufrufen und den ersten Bereich der erweiterten Einstellung des Mahlgrads wählen. Drehen Sie dann den Mengenregler (B2) auf MIN und stellen Sie die Menge wie beim ersten Gebrauch ein (siehe „Die „perfekte Menge““).

8.5 Reinigung der „Smart Tamping Station“

1. Reinigen Sie den Bereich zum Einrasten mit einem Pinsel (Abb. 35).
2. Ziehen Sie den Hebel (A20) bis zum Anschlag und reinigen Sie den Tamper mit einem Pinsel (Abb. 36); lassen Sie dann den Hebel wieder los.
3. Reinigen Sie die Kaffeerrutsche mit einer Bürste (C7)(Abb. 37).

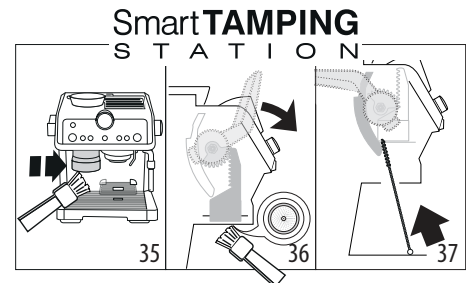

9. WASSERHÄRTE

Die Kontrolllampe (B9) Entkalkung schaltet sich nach einer voreingestellten Betriebszeit ein, die von der Wasserhärte abhängt. Die Kaffeemaschine kann je nach der in den verschiedenen Wohnregionen vorhandenen Wasserhärte programmiert werden, sodass die Entkalkung weniger häufig durchgeführt werden muss.

1. Nehmen Sie den mitgelieferten Reaktionsstreifen „TOTAL HARDNESS TEST“ (C4) aus seiner Packung;
2. Den Streifen etwa eine Sekunde lang vollständig in ein Glas Wasser eintauchen.
3. Den Streifen aus dem Wasser nehmen und leicht schütteln. Stellen Sie das Gerät gemäß den Angaben im Kapitel „7. Menü Einstellungen“ ein.

Ergebnis Wasserhärtestest	Taste	Stufe
	×2	1 weiches Wasser
	≡ 0°	2 normales Wasser
	OK	3 hartes oder sehr hartes Wasser

4. Stellen Sie das Gerät gemäß den Angaben im Kapitel „7. Menü Einstellungen“ ein.

10. VERWENDUNG VON SOFTBALLS

Softballs (C9) ist ein innovatives System, das die Lebensdauer der Kaffeemaschine verlängert, ohne die Wasserqualität zu beeinflussen, und so die Ausgabe eines cremigen und aromatischen Kaffees garantiert. Um die Wirksamkeit zu optimieren, sollte Softballs vor dem Gebrauch über Nacht im Wasser gelassen werden.

1. Nehmen Sie das Softballs-Paket aus der Verpackung (Abb. 38).

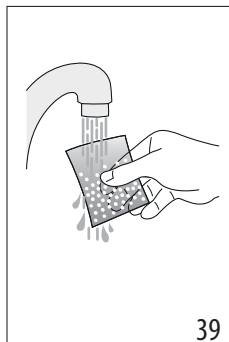
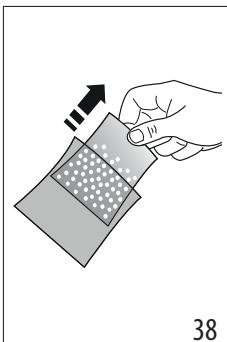

2. Spülen Sie das Softballs-Paket unter fließendem Wasser ab (Abb. 39).
3. Tauchen Sie den Beutel in den Wassertank (A14) (Abb. 40).

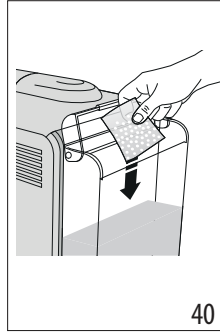

4. Tauschen Sie den Softballs-Beutel alle 3 Monate aus (Abb. 41).

11. ENTKALKUNG

Vorsicht!

- Vor dem Gebrauch lesen Sie bitte die Gebrauchsanweisung und die Angaben auf dem Etikett des Entkalkers (C5) durch, die sich auf der Packung des Entkalkers befinden.
- Verwenden Sie ausschließlich Entkalker von De'Longhi. Die Verwendung von ungeeigneten Entkalkern sowie die nicht regelmäßig durchgeführte Entkalkung können zum Auftreten von Defekten führen, die nicht durch die Herstellergarantie abgedeckt sind.
- Der Entkalker kann empfindliche Oberflächen beschädigen. Sollte das Produkt versehentlich verschüttet werden, bitte sofort wischen.

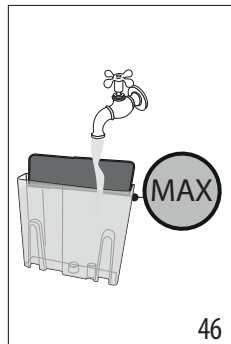
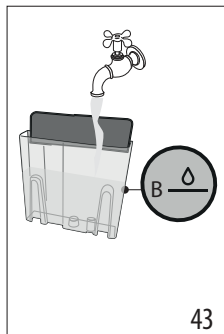
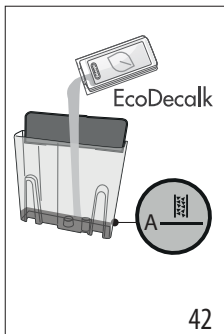

Zur Durchführung der Entkalkung	
Entkalker	Entkalker De'Longhi
Behälter	Fassungsvermögen 2 Liter
Zeit	~40min

1. (FALLS VORHANDEN, DEN WASSERFILTER UND SOFTBALLS ENTFERNEN). Geben Sie den Entkalker bis zum auf der Innenseite des Tanks aufgedruckten Füllstand A in den Wassertank (A14) (entspricht einer 100ml Packung) (Abb. 42).

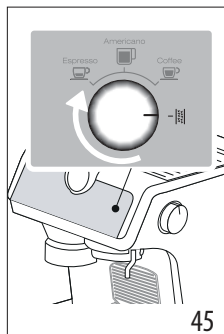
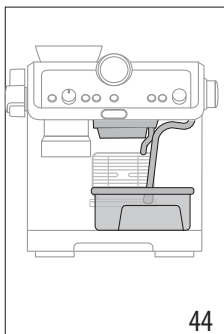

2. Füllen Sie bis zum Füllstand B mit Wasser auf (Abb. 43). Setzen Sie dann den Wassertank wieder in die Kaffeemaschine ein.



3. Stellen Sie sicher, dass der Siebträger (C1) nicht eingerastet ist, und stellen Sie ein Gefäß unter den Kaffee- und Heißwasser- auslauf und unter das Dampfaußgaberohr (A6) (Abb. 44).
4. Drehen Sie den Drehknopf (B8) auf  (Abb. 45): die Kontrolllampe OK schaltet sich in Orange ein; die Kontrolllampe  blinkt.
5. Drücken Sie die Taste OK: die Kontrolllampe OK blinkt.
6. Das Entkalkungsprogramm startet und die Entkalkungslösung tritt aus den Ausläufen heraus. Das Entkalkungsprogramm führt automatisch eine Reihe von Spülvorgängen und Pausen durch, um die Kalkablagerungen in der Kaffeemaschine zu beseitigen, bis der Tank vollständig geleert ist.

Die Ausgabe wird abgebrochen und die Kontrolllampe OK wird weiß. Nun muss ein Spülvorgang durchgeführt werden:











7. Leeren Sie das zum Auffangen der Entkalkungslösung verwendete Gefäß und stellen Sie es erneut unter die Ausläufe.
8. Entnehmen Sie den Wassertank, leeren Sie mögliche Rückstände der Entkalkungslösung aus, spülen Sie den Tank unter fließendem Wasser aus und füllen Sie ihn bis zum Füllstand MAX mit frischem Wasser (Abb. 46). Setzen Sie dann den Wassertank wieder in seine Aufnahme.





9. Drücken Sie die Taste OK: der Spülvorgang beginnt.
10. Nach Beendigung des Spülvorgangs wird die Ausgabe abgebrochen und das Gerät ist betriebsbereit.
11. Leeren Sie die zum Auffangen des Spülwassers verwendeten Gefäße.
12. Ziehen Sie die Abtropfschale heraus, leeren Sie sie und setzen Sie sie dann wieder ein.
13. Ziehen Sie den Wassertank heraus, füllen Sie ihn mit frischem Wasser und setzen Sie ihn dann wieder ein. Nun ist das Gerät betriebsbereit.





Hinweis:





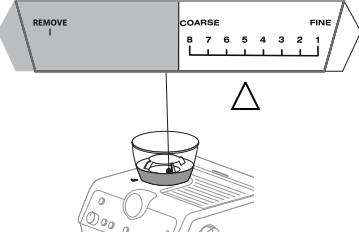

- Der Entkalkungszyklus kann jederzeit gestartet werden (auch wenn die entsprechende Kontrolllampe noch nicht eingeschaltet ist).
- Falls die Entkalkung versehentlich gestartet wurde, drücken Sie die Taste OK für 10 Sekunden; der Spülvorgang kann nicht abgebrochen werden.

12. BEDEUTUNG DER KONTROLLAMPEN



KONTROLLAMPEN	BEDEUTUNG KONTROLLAMPEN	DER	VORGANG
Alle Kontrolllampen blinken kurz auf	Einschalten des Geräts		Eigendiagnose
 leuchtet permanent	Die Kaffeemaschine wurde zum ersten Mal eingeschaltet und der Kreislauf muss mit Wasser gefüllt werden		Gemäß den Angaben im Kapitel vorgehen "3. Erste Inbetriebnahme des Gerätes"
 leuchtet permanent (weiß) <ul style="list-style-type: none"> Kontrolllampe  zeigt die gewählte Kaffeetemperatur an Kontrolllampe  : zeigt an, dass die Maschine für die Heißwasserausgabe bereit ist 	Die Kaffeemaschine ist für die Ausgabe bereit		Bereiten Sie die Kaffeemaschine vor und bereiten Sie das Getränk zu
 leuchtet permanent	Der Energiesparmodus ist aktiv		Auf den Abschnitt "7. Menü Einstellungen" Bezug nehmen, wenn die Funktion deaktiviert werden soll
 leuchtet permanent	Der Kaffeebohnenbehälter (A2) ist leer		Kaffeebohnenbehälter füllen
 blinkt	Der Mahlvorgang soll durchgeführt werden, aber der Kaffeebohnenbehälter (A2) ist leer		Kaffeebohnenbehälter füllen
 blinkt in regelmäßigen Abständen kurz auf	Der Drehknopf (B2) ist auf die höchste Stufe gestellt 		Wenn nach dem Mahlvorgang zu wenig Kaffee im Sieb ist, muss gemäß den Angaben im Kapitel "6. Menü settings" ein neuer Mahlbereich gewählt werden.
 leuchtet permanent	Das Wasser im Tank (A14) ist nicht ausreichend oder der Wassertank ist nicht richtig eingesetzt		Den Wassertank füllen oder den Wassertank entnehmen und wieder korrekt einsetzen
			→

KONTROLLAMPEN	BEDEUTUNG KONTROLLAMPEN	DER	VORGANG
 blinkt	Ein Getränk soll zubereitet werden, aber der Wassertank (A14) ist leer		Den Wassertank füllen
	Der Mahlgrad ist zu fein, sodass der Kaffee zu langsam oder gar nicht herausläuft		Den Siebträger (C1) entnehmen, die Vorgänge für die Kaffeezubereitung wiederholen und dabei die Angaben im Abschnitt „4.1 Schritt 1 - Mahlvorgang (grinding)“ und „4.2 Schritt 2 - Anpressen (tamping)“ beachten
	Das Kaffeesieb (C2) oder (C3) ist verstopft		Die Filter unter fließendem Wasser abspülen
	Der Wassertank (A14) ist nicht richtig eingesetzt und die Ventile am Boden sind nicht geöffnet		Den Wassertank leicht andrücken, damit sich die Ventile öffnen
	Kalk im Wasserkreislauf		Die Entkalkung gemäß Kapitel „11. Entkalkung“ durchführen
 leuchtet permanent	Das Gerät ist für die Dampfausgabe bereit		Das Gerät hat die Temperatur erreicht, um Dampf auszugeben. Für die Ausgabe den Ausgabeknopf für Dampf (A4) drehen
 blinkt	Das Gerät ist eingeschaltet und der Energiesparmodus ist aktiv: der Ausgabeknopf für Dampf (A4) ist eingestellt, um Dampf auszugeben		Die Kontrolllampe blinkt, um anzuzeigen, dass das Gerät sich vorbereitet, um Dampf auszugeben: die Ausgabe beginnt, sobald das Gerät aufgeheizt ist
	Das Gerät ist für die Dampfausgabe bereit		Das Gerät ist für die Dampfausgabe aufgeheizt, wenn die Kontrolllampe permanent leuchtet
	Das Gerät gibt gerade Dampf aus		
 leuchtet permanent	Der Kaffeebohnenbehälter ist nicht eingesetzt		Den Kaffeebohnenbehälter (A2) richtig einsetzen oder überprüfen, dass er richtig eingesetzt ist. Der Behälter ist richtig eingesetzt, wenn der Pfeil ▲ mit dem Symbol ☐ übereinstimmt und ein „Klicken“ zu hören ist
			→

KONTROLLAMPEN	BEDEUTUNG DER KONTROLLAMPEN	VORGANG
 blinkt	<p>Der Wahlschalter des Mahlgrads ist nicht richtig eingestellt oder die maximal mögliche Einstellung ist überschritten</p> <p>AUSSERHALB des richtigen Bereichs range</p> 	<p>Den Wahlschalter wieder auf eine der Mahlpositionen (zwischen 1 und 8) stellen und dabei folgendes beachten:</p> <ul style="list-style-type: none"> • Den Mahlgrad einstellen während das Mahlwerk in Betrieb ist • Immer nur um eine Stufe verstellen und zwischen zwei Einstellungen mindesten 5 Mahlvorgänge durchführen
 leuchtet permanent	<p>Das Gerät fordert das Anpressen an</p> <p>Der Siebträger wurde ohne Anpressen vom Mahlwerk ausgerastet</p> <p>Der Siebträger wurde ausgerastet, ohne den Mahlvorgang zu beenden, oder das Anpressen ist zu früh erfolgt</p> <p>Die Kaffeerutsche des Mahlwerks ist verstopft</p> <p>Die Mahlwerkzeuge sind durch einen Fremdkörper blockiert</p>	<p>Der Mahlvorgang wurde gerade durchgeführt und der Siebträger ist am Mahlwerk eingerastet</p> <p>Den Siebträger ausrasten und den Kaffee, wie im Abschnitt beschrieben, anpressen "Die „perfekte Menge“" "Wenn vorgemahlener Kaffee verwendet wird:"</p> <p>Den Mahlvorgang wiederholen</p> <p>Wie im Abschnitt "8.5 Reinigung der „Smart Tamping Station“" beschrieben, die Reinigung durchführen. Wenn das Problem weiterhin besteht, die entsprechende Tür öffnen und die Rutsche mithilfe der Bürste von der Verstopfung befreien</p> <p>Den Fremdkörper entfernen und die Mahlwerkzeuge reinigen, wie im Abschnitt „8.3 Reinigung der Mahlwerkzeuge“ beschrieben.</p>
 leuchtet permanent (rot)	<p>Die Entkalkung muss durchgeführt werden</p>	<p>Die Entkalkung durchführen, wie im Kapitel erläutert "11. Entkalkung"</p>
 blinkt (rot) +  blinkt (orange)	<p>Das Gerät führt gerade die Entkalkung durch</p>	<p>Den Vorgang zu Ende führen, wie im Kapitel "11. Entkalkung" beschrieben</p>
→		

KONTROLLAMPEN	BEDEUTUNG DER KONTROLLAMPEN	VORGANG
 blinkt (rot) +  leuchtet permanent (weiß)	Der Spülvorgang muss durchgeführt werden	
 blinkt (rot) +  blinkt (weiß)	Das Gerät führt gerade den Spülvorgang des Entkalkungszyklus durch	
 leuchtet permanent (orange)	Die Reinigung des Kaffeeauslaufs muss durchgeführt werden	Siehe Abschnitt "8.1 Reinigung des Kaffeeauslaufs"
 blinkt (orange)	Das Gerät führt gerade die Reinigung des Kaffeeauslaufs durch	
Alle Kontrolllampen blinken	Allgemeine Störung	Wenden Sie sich an eine Kundendienststelle

13. BETRIEBSSTÖRUNGEN

PROBLEM	URSACHE	ABHILFE
In der Abtropfschale (A10) befindet sich Wasser	Dies gehört zum normalen Betrieb der internen Kreisläufe der Kaffeemaschine	Die Abtropfschale regelmäßig leeren und reinigen
Der Espresso läuft nicht mehr heraus	Kein Wasser im Tank (A14)	Den Tank füllen
	Die Kontrolllampe  (B6) ist eingeschaltet, um anzuzeigen, dass der Kaffeekreislauf oder der Dampfkreislauf leer ist.	Die Taste für die Kontrolllampe  drücken, um den Kreislauf zu füllen
	Das Sieb (C2) oder (C3) ist verstopft	Die Filter unter fließendem Wasser abspülen
	Der Wassertank (A14) ist nicht richtig eingesetzt und die Ventile am Boden sind nicht geöffnet	Den Wassertank leicht andrücken, damit sich die Ventile am Boden öffnen
	Kalk im Wasserkreislauf	Die Entkalkung gemäß Kapitel "11. Entkalkung"durchführen
	Mahlgrad zu fein	Den Siebträger (C1) entnehmen, die Vorgänge für die Kaffeezubereitung wiederholen und dabei die Angaben im Abschnitt "4.1 Schritt 1 - Mahlvorgang (grinding)"und "4.2 Schritt 2 - Anpressen (tamping)"beachten
Der Siebträger rastet nicht am Gerät ein	Das Kaffeepulver wurde nicht gepresst oder die Menge ist zu groß	Den Mahlvorgang mit anderen Einstellungen wiederholen. Die Dosiermenge reduzieren: überprüfen, dass das Sieb (C2) oder (C3) (1 oder 2 Tassen) für die zu mahrende Menge richtig ist (Taste 2x (B3) gewählt oder nicht)
→		

PROBLEM	URSACHE	ABHILFE
Der Espresso tropft über die Ränder des Siebträgers (C1) anstatt aus den Löchern	Der Siebträger ist nicht richtig eingesetzt	Den Siebträger richtig einrasten und kräftig bis zum Anschlag drehen
	Die Dichtung des Kaffeeauslaufs (A18) hat an Elastizität verloren oder ist verschmutzt	Die Dichtung des Kaffeeauslaufs bei einem Kundendienstzentrum austauschen
	Das Sieb (C2) oder (C3) ist verstopft	Die Filter unter fließendem Wasser abspülen
Die Crema des Kaffees ist hell (der Kaffee läuft zu schnell aus dem Ausguss)	Die Einstellungen des Gerätes müssen überprüft werden	Den Siebträger entnehmen, die Vorgänge für die Kaffeezubereitung wiederholen und dabei die Angaben im Abschnitt "4.1 Schritt 1 - Mahlvorgang (grinding)" und "4.2 Schritt 2 - Anpressen (tamping)" beachten
Die Crema des Kaffees ist dunkel (der Kaffee läuft zu langsam aus dem Ausguss)	Die Einstellungen des Gerätes müssen überprüft werden	Den Siebträger (C1) entnehmen, die Vorgänge für die Kaffeezubereitung wiederholen und dabei die Angaben im Abschnitt „4.1 Schritt 1 - Mahlvorgang (grinding)“ und „4.2 Schritt 2 - Anpressen (tamping)“ beachten
Nach Beendigung der Entkalkung fordert das Gerät einen weiteren Spülvorgang an	Während des Spülvorgangs wurde der Tank nicht bis zum Füllstand MAX gefüllt	Den Spülvorgang wiederholen (siehe Kapitel "11. Entkalkung")
Das Gerät mahlt den Kaffee nicht	Im Mahlwerk befindet sich ein Fremdkörper	Die Mahlwerkzeuge gemäß den Angaben im Abschnitt „8.3 Reinigung der Mahlwerkzeuge“ reinigen und sich dabei vergewissern, dass alle Bohnen aus dem Kaffeebohnenbehälter (A2) entfernt wurden, bevor er herausgezogen wird. Bevor das Mahlwerkzeug wieder eingebaut wird, müssen alle Rückstände sorgfältig von seiner Aufnahme abgesaugt werden
	Der Kaffeebohnenbehälter (A2) befindet sich nicht in der richtigen Position	Der Behälter ist richtig eingesetzt, wenn der Pfeil ▲ mit dem Symbol ☞ übereinstimmt und ein „Klicken“ zu hören ist
→		

PROBLEM	URSACHE	ABHILFE
Wenn die Kaffeesorte gewechselt werden soll	Es müssen alle in der Kaffeemaschine vorhandenen Kaffeebohnen entfernt werden	<ul style="list-style-type: none"> • Den Kaffeebohnenbehälter (A2) leeren (das Mahlwerk leer laufen lassen oder restliche Kaffeebohnen eventuell aufsaugen) • Den Siebträger (C1) einrasten und das Mahlwerk „leer“ laufen lassen, um den Kaffeeschacht zu befreien: dann den Siebträger am Ausgang des Mahlwerks (A19) einrasten, indem er zum Text INSERT ausgerichtet wird, und den Siebträger nach rechts drehen. Der Mahlvorgang beginnt, wenn der Siebträger die Position CLOSE erreicht und wird automatisch abgebrochen. Den Vorgang wiederholen, bis das Sieb leer bleibt • Den Behälter (A2) mit der neuen Kaffeebohnen-sorten füllen • Wenn beim Mahlvorgang nicht die „perfekte Menge“ erreicht wird, wie beim ersten Gebrauch vorgehen
Nach dem Mahlvorgang ist das Kaffeesieb (C2) oder (C3) leer	Die Kaffeerutsche des Mahlwerks ist verstopft	Wie im Abschnitt „8.5 Reinigung der „Smart Tamping Station““ beschrieben, die Reinigung durchführen. Wenn das Problem weiterhin besteht, die entsprechende Tür (A21) öffnen und die Rutsche mithilfe der Bürste von der Verstopfung befreien
Nach dem Mahlvorgang ist zu viel Kaffeepulver im Sieb		
		→

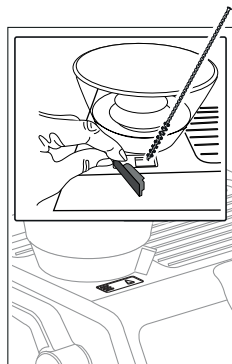

PROBLEM	URSACHE	ABHILFE
Nach dem Mahlvorgang erreicht das Kaffeepulver im Sieb (C2) oder (C3) nicht die „perfekte Menge“	Die „Smart Tamping Station“ muss gereinigt werden	Wie im Abschnitt „8.5 Reinigung der „Smart Tamping Station““ beschrieben, die Reinigung durchführen, dann den Mahlvorgang wiederholen
	Die Kaffeepulvermenge muss eingestellt werden	Die Menge mit dem entsprechenden Drehknopf (B2) einstellen, indem die Angaben im Abschnitt „Die „perfekte Menge““ befolgt werden. Wenn der Drehknopf bereits auf höchster Stufe steht, gemäß den Angaben im Abschnitt „7. Menü Einstellungen“ - „Erweiterte Einstellung des Mahlgrads“ vorgehen
	Mit der Zeit nutzen sich die Mahlwerkzeuge ab	Die Mahlwerkzeuge, wie im Abschnitt „8.4 Austauschen der Mahlwerkzeuge“ beschrieben, austauschen

Lees altijd het boekje met de veiligheidsvoorschriften voordat u het apparaat gebruikt.

1. BESCHRIJVING

1.1 Beschrijving van het apparaat - A

- A1. Deksel koffiebonenreservoir
- A2. Koffiebonenreservoir
- A3. Kopjesblad
- A4. Stoomknop
- A5. Afgiftepijpje heet water
- A6. Stoompijpje
- A7. Kopjesrooster voor espresso
- A8. Kopjesrooster voor glazen of bekers
- A9. Rooster drupbakje
- A10. Drupbakje
- A11. Indicator waterniveau van het drupbakje
- A12. Deksel waterreservoir
- A13. Handgreep uitnemen waterreservoir
- A14. Waterreservoir
- A15. Zitting verzachtingsfilter
- A16. Zitting aansluiting voedingskabel
- A17. Hoofdschakelaar (ON/OFF)
- A18. Koffieuitloop
- A19. Uitlaat koffiemolen (Tamping station)
- A20. Hendel koffiestamper
- A21. Luikje voor bereiken koffiegoot koffiemolen

1.2 Beschrijving bedieningspaneel - B

- B1. Toets ON/Stand-by
- B2. Regelknop hoeveelheid gemalen koffie
- B3. Toets "X2": voor gebruik filter 2 kopjes koffie
- B4. Toets "koffietemperatuur"
- B5. Toets "OK": voor afgifte drank / voor bevestiging
- B6. Toets "afgifte heet water"
- B7. Toets "My": voor personalisatie hoeveelheid dranken
- B8. Selectieknop functies
 - Espresso
 - Americano
 - Koffie
 - Ontkalken
- B9. Lampje "ontkalking"
- B10. Lampje "stoom klaar"
- B11. Lampje "koffiebonenreservoir ontbreekt"
- B12. Lampje "energiebesparing"
- B13. Lampje "Reiniging" (zie "8.1 Reiniging koffieuitloop")
- B14. Lampje "koffiebonenreservoir leeg"
- B15. Lampje "geen water"
- B16. Lampje "koffiestamper"
- B17. Manometer

1.3 Beschrijving van de accessoires - C

- C1. Filterhouder
- C2. Filter 1 kopje
- C3. Filter 2 kopjes
- C4. Teststrookje "Total Hardness Test"
- C5. Ontkalker
- C6. Afneembare voedingskabel
- C7. Rond borsteltje
- C8. Reinigingsaccessoire koffieuitloop
- C9. Softballs
- C10. Melkkan
- C11. Naald reiniging stoomsproeier

1.4 Niet inbegrepen accessoires reiniging, aanbevolen door de fabrikant

Ga voor meer informatie naar de website Delonghi.com.



Reinigingstabletten

(Zie "8.1 Reiniging koffieuitloop")



Reinigingsmiddel

EAN: 8004399333307

2. HET APPARAAT VOORBEREIDEN

Was alle accessoires met lauwwarm water en afwasmiddel en ga dan als volgt verder:

1. Plaats het koffiebonenreservoir (A2) in de koffiemolen (afb. 1). Het reservoir is correct geplaatst als het pijltje ▲ is uitgelijnd met het symbool ☞ en er een "klik" wordt gehoord (afb. 2).
2. Plaats het drupbakje (A10) compleet met het kopjesrooster (A8) en het rooster van het drupbakje (A9) (afb. 3);
3. Verwijder het waterreservoir (A14) (afb. 4) en vult het tot aan de aanduiding MAX met vers en schoon water (afb. 5).
4. Plaats het waterreservoir dan terug.

Opgelet: Stel het apparaat nooit in werking zonder water in het reservoir of zonder het reservoir.

Opgelet: Wij raden u aan de waterhardheid zo spoedig mogelijk in te stellen, volgens de procedure beschreven in hoofdstuk "7. Menu instellingen".

3. EERSTE INWERKINGSTELLING VAN HET APPARAAT

1. Steek de connector van de voedingskabel (C6) in de daarvoor bestemde aansluiting (A16) op de achterkant van het apparaat (afb. 6); steek vervolgens de stekker in het stopcontact. Zorg ervoor dat de hoofdschakelaar (A17), op de achterkant van het apparaat, geplaatst is op stand I (afb. 7);
2. Plaats onder het afgiftepijpje heet water (ter hoogte van de koffieuitloop (A18)) een bakje met een minimuminhoud van 100 ml (afb. 8);
3. Druk op toets (B6) in overeenstemming met het lampje ☞ (afb. 9): de afgifte start en wordt vervolgens automatisch onderbroken. Maak het bakje leeg.

Voorafgaand aan het eerste gebruik van de machine moeten haar interne circuits gespoeld worden. Ga als volgt te werk:

4. Breng de filterhouder (C1), compleet met filterzeef, aan op de machine: voor een correcte bevestiging moet de greep van de filterhouder uitgelijnd worden met "INSERT" (afb. 10) en vervolgens naar rechts worden gedraaid tot hij is uitgelijnd met de stand "CLOSE";
5. Plaats een bakje onder de filterhouder en onder het stoompijpje (A6);
6. Druk op de toets OK (B5) (afb. 11): de afgifte begint;
7. Draai, na het voltooiën van de afgifte, de stoomknop (A4) (afb. 12) en laat enkele seconden stoom afgeven om het stoomcircuit te spoelen: voor een optimale stoomafgifte wordt aangeraden deze handeling 3 of 4 keer te herhalen. Op deze manier wordt het water uit het pijpje verwijderd alvorens stoom af te geven.

Het apparaat is nu klaar voor gebruik.

Opgelet: de spoeling van de interne circuits wordt ook aangeraden in geval van een langdurig niet-gebruik van het apparaat.

Bij het eerste gebruik moeten er 4-5 kopjes koffie worden gezet voordat de machine een bevredigend resultaat begint te geven: besteed bijzondere aandacht aan de hoeveelheid gemalen koffie in het filter ((C2) of (C3)) (zie de aanwijzingen van paragraaf "4.1 Fase 1 - Malen (grinding)").

Ga verder zoals aangegeven in hoofdstuk "De "perfecte dosis"".

4. KOFFIE ZETTEN

4.1 Fase 1 - Malen (grinding)

1. Giet de koffiebonen in het reservoir (A2) (fig. 13). Aangeraden wordt om slechts de hoeveelheid koffiebonen toe te voegen die noodzakelijk is voor de bereiding: op deze manier gebruikt u altijd verse koffie;
2. Selecteer de maalgraad (afb. 14). De fabrieksinstelling is 5 (gemiddelde maalgraad). Als het resultaat niet bevredigend is, pas het niveau dan aan op basis van uw persoonlijke smaak en het type koffie (de regeling moet gebeuren tijdens de werking van de koffiemolen).

Opgelet: Voor de meeste soorten koffie wordt een maalgraad tussen 3 en 6 aanbevolen. De instelling van de maalgraad op 1 of 2 geeft een zeer fijn gemalen koffie, alleen te gebruiken voor speciale soorten koffie (licht gebrand).

3. Plaats een van de filterzeven (C2) of (C3) in de filterhouder (C1) (afb. 15). Als de filterzeef voor 2 kopjes wordt gebruikt, druk dan op toets 2X (B3): met deze selectie wordt ook de afgegeven hoeveelheid espresso verdubbeld.
4. Stel de regelknop hoeveelheid (B2) in; begin bij de minimale stand (afb. 16).

Verwijs naar paragraaf "Aanpassing van de hoeveelheid koffie in de filterzeef" voor meer informatie.

5. Bevestig de filterhouder op de uitloop van de koffiemolen (A19) en lijn het opschrift INSERT uit: draai de filterhouder vervolgens naar rechts. De maling start wanneer de houder de stand CLOSE bereikt en wordt automatisch onderbroken.

Aanpassing van de hoeveelheid koffie in de filterzeef

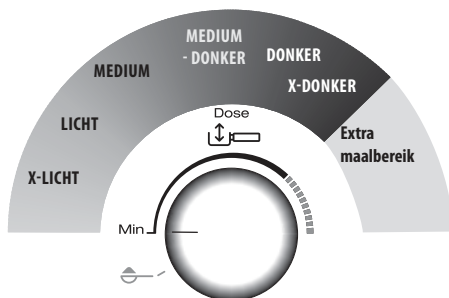

De verschillende soorten koffiebonen geven tijdens de maling verschillende resultaten; om deze reden is er aan het begin van de regeling van de dosering uiterste aandacht nodig.

Deze afbeelding geeft aan hoe de dosis moet worden aangepast op basis van de kleur van de gebrande koffie: neem deze aanwijzingen als uitgangspunt, maar het resultaat kan variëren op basis van de samenstelling van de koffiebonen.

1. Stel de dosis in vanaf de minimale stand.
2. Verwijs naar de kleur van de gebrande koffiebonen en draai de knop langzaam.

4.2 Fase 2 - Aanstampen (tamping)

1. Verplaats, na het malen, de hendel voor aanstampen (A20) omlaag naar de uiterste stand (verwijder de filterhouder niet) (afb. 17). Voor een perfect resultaat moet deze handeling 2 maal herhaald worden.
2. Houd de hendel op de uiterste lage stand tijdens de verwijdering van de filterhouder (afb. 18). Breng de hendel vervolgens terug naar de uitgangsstand.
3. Controleer of de koffiedosis correct is (zie "De "perfecte dosis"",) en breng de filterhouder aan op de koffieuitloop (A18) (afb. 19).

Opgelet: Als er na het aanstampen koffie achterblijft op de randen van het filter, zal dit geen gevolgen hebben voor de kwaliteit van de extractie en dus het eindresultaat.

De "perfecte dosis"

- De koffiefilters hebben aan hun binnenkant een markering voor de identificatie van de perfecte dosis.



- Filters met lasermarkering: de perfecte dosis komt overeen met de bovenste lijn van de markering;
 - Filters met reliëfmarkering: de perfecte dosis komt overeen met de reliëflijn;
- Controleer of de koffie na het aanstampen het correcte niveau heeft. Mogelijk moet de knop (B2) meerdere keren geregeld worden voordat de perfecte dosis wordt gevonden.
 - Als de afgegeven koffie te sterk of te slap is en de dosis in de filterzeef is perfect, stel dan een fijnere of grovere maalgraad in (zie "4.1 Fase 1 - Malen (grinding)"). Als de koffie te sterk is (te langzame afgifte), dan moet de maalgraad grover zijn. Als de koffie te slap is (te snelle afgifte), dan moet de maalgraad fijner zijn.
 - **De barista adviseert:** Verwijder de filterhouder terwijl u de hendel van de koffiestamper (A20) omlaag houdt, om een perfecte afwerking van de koffiedosis te verkrijgen.
 - **In geval van gebruik van voorgemalen koffie:**
 - vul de filterzeef met voorgemalen koffie;
 - draai de knop naar ;
 - breng de filterhouder aan op de uitgang van de koffiemolen;
 - verplaats de hendel van de koffiestamper omlaag.

4.3 Fase 3 - Afgifte (brewing)



1. Selecteer de temperatuur (afb. 20) (zie "De temperatuur het de koffieafgifte").
2. Selecteer de gewenste drank (afb. 21).
3. Druk op OK (B5) om de afgifte te starten (afb. 11) (voor-infusie en infusie). De koffieafgifte wordt automatisch onderbroken.

De temperatuur het de koffieafgifte

De temperatuur van het water wordt gedurende het gehele bereidingsproces gecontroleerd om stabiliteit ervan tijdens de extractiefase te garanderen. De Specialista Prestigio biedt 3 infusietemperaturen* die overeenkomen met een bereik tussen 92°C en 96°C.

Afhankelijk van het soort en het brandingsniveau van de koffiebonen worden verschillende temperaturen aanbevolen: Robusta-bonen vereisen een lage temperatuur, terwijl Arabica-bonen een hoge temperatuur behoeven. Hetzelfde geldt voor donker gebrande koffiebonen of voor pas gebrande bonen.

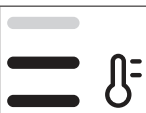
Temperatuurniveau	Overeenkomstig lampje	Brandingsniveau
MIN		Donker

MED		Medium-donker
MAX		Licht - medium

- * Deze temperatuur verwijst naar het water in het thermoblock. Het betreft dus niet de temperatuur van de drank in het kopje of de temperatuur gemeten bij de afgifte van de drank uit de tuitjes van de filterhouder.

5. BEREIDING MELKDRANKEN

5.1 Melk opschuimen

1. Vul de melkkan (C10) met de te verwarmen/op te schuimen hoeveelheid melk; houd er rekening mee dat het volume van de melk 2 of 3 keer zal toenemen (afb. 22). Voor rijker en gladder schuim wordt aangeraden om volle koemelk op koelkasttemperatuur te gebruiken (ongeveer 5°C).

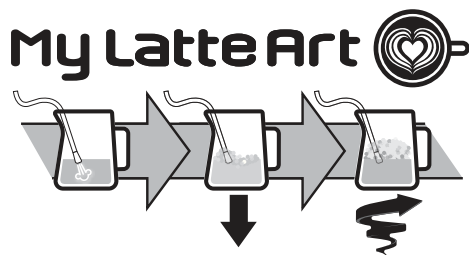

2. Voor het opschuimen van de melk, moet het stoompijpje (A6) op het oppervlak van de melk steunen: op deze manier zal de lucht zich mengen met de melk en de stoom.
3. Houd het stoompijpje op het oppervlak van de melk en let op niet te veel lucht te mengen om grote luchtballen te voorkomen.
4. Dompel het stoompijpje onder het oppervlak van de melk: op deze manier ontstaat er een draaikolk. Draai de stoomknop dicht na het bereiken van de gewenste temperatuur en wacht tot de stoomafgifte volledig stopt alvorens de melkkan weg te nemen.

De barista adviseert:

- **Geef de voorkeur aan verse melk.** Gebruik altijd verse melk op koelkasttemperatuur.
- Voor optimale resultaten wordt aangeraden om de melkkan altijd in de koelkast te bewaren.
- Volle melk geeft de beste resultaten. Het resultaat en de textuur van het schuim variëren afhankelijk van de gebruikte koemelk of plantaardige drank.

- Verwijder na het opschuimen van de melk, de luchtbellen door de melkkan een draaiende beweging te laten maken.

Reiniging van het stoompijpe:







1. Na elk gebruik moeten de melkresten met een doek van het stoompijpe verwijderd worden (afb. 23). Voor een grondige reiniging wordt aangeraden het product Eco MultiClean te gebruiken: op deze manier wordt de hygiëne gewaarborgd door de melkeiwitten en -vetten te verwijderen. Het product kan voor de reiniging van de gehele machine gebruikt worden.
2. Laat gedurende enkele seconden stoom afgeven om het stoompijpe goed schoon te maken (afb. 12).
3. Wacht tot het stoompijpe is afgekoeld: om de efficiëntie van het pijpe constant te handhaven, moet de naald voor de reiniging (C11) worden gebruikt om de 3 gaatjes vrij te houden (afb. 24).

6. PERSONALISATIE VAN DE HOEVEELHEID VAN DE KOFFIEDRANKEN MET TOETS (my) (B7)

1. Bereid de machine voor, voor het zetten van 1 of 2 kopjes van de gewenste koffiedrank, tot aan het aanbrengen van de filterhouder (C1), compleet met filterzeef (C2) of (C3) en gemalen koffie.
2. Draai de knop (B8) om de te programmeren drank te selecteren.
3. Druk op de toets (my): het met de toets overeenkomende lampje (my) knippert.
4. Druk op de toets OK om de afgifte te starten. De lampjes van de toetsen OK en (my) knipperen.
5. Druk, wanneer de gewenste hoeveelheid wordt bereikt, op OK. Als de drank de afgifte van een ander ingrediënt voorziet, zal deze afgifte starten: druk, wanneer de gewenste hoeveelheid wordt bereikt, op OK.
6. Druk op toets (my) om op te slaan. Het apparaat is klaar voor een nieuw gebruik en het lampje (my) blijft continu branden. Als u het programma niet wenst op te slaan, druk dan op een willekeurige andere toets.

Opgelet:

- *Het is mogelijk om de dranken met koffie te programmeren, maar niet de afgifte van stoom en heet water.*
- *De programmering wijzigt de hoeveelheden van de dranken, maar niet van de gemalen koffie.*
- *De dranken "X2" kunnen apart geprogrammeerd worden.*
- **Houd, om terug te keren naar de fabrieksinstellingen, de toets (my) ingedrukt tot aan de uitschakeling. De geselecteerde drank keert terug naar de fabrieksinstelling.**

Recept koffie	Hoeveelheid fabrieksinstelling	Programmeerbare hoeveelheid
 Espresso	35 ml	van 25 tot 90 ml
 Espresso X2	70 ml	van 50 tot 180 ml
 Coffee	80 ml	van 50 tot 120 ml
 Coffee X2	160 ml	van 120 tot 240 ml
 Americano	120 ml	<ul style="list-style-type: none"> • espresso: van 25 tot 60 ml • water: van 25 tot 120 ml
 Americano X2	240 ml	<ul style="list-style-type: none"> • espresso: van 50 tot 120 ml • water: van 50 tot 240 ml



7. MENU INSTELLINGEN

1. Open het menu:

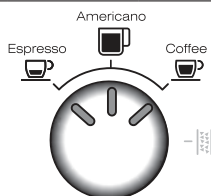

Druk gedurende 5 seconden gelijktijdig op	x2	(my)
---	----	------

2. Instellingen met selectie door middel van knop (B8)



Overeenkomstige instelling	Draai naar	Instellingen
Extra instelling van de maalgraad		x2 ➔ Bereik 1
		☰ ➔ Bereik 2
Waterhardheid		x2 ➔ zacht
		☰ ➔ middelhard
		(OK) ➔ hard/zeer hard

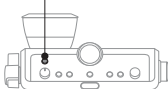

Automatische uitschakeling	 Coffee	×2 → 9 minuten
		☰ → 1,5 uur
		OK → 3 uur
3. Instelling met selectie door middel van toets:		
Energiebesparing	 → Actief	
	 →  Uitgeschakeld	
Fabriekswaarden	Houd de toets  ten minste 5 seconden ingedrukt, tot het lampje continu blijft branden	
4. Sla de nieuwe instellingen op door te drukken op ON/Standby (B1)		
 		











8. REINIGING VAN HET APPARAAT

Let op!

- Gebruik voor de reiniging van de machine geen oplosmiddelen, schurende reinigingsmiddelen of alcohol.
- Gebruik geen metalen voorwerpen om aanslag of koffieresten te verwijderen omdat ze de metalen of plastic oppervlakken kunnen beschadigen.
- Als de machine langer dan één week niet wordt gebruikt, wordt aangeraden een spoeling uit te voeren alvorens de ze weer te gebruiken.

Gevaar!

- Dompel het apparaat tijdens de reiniging nooit onder in water: het is een elektrisch apparaat.
- Voordat de buitenkant van het apparaat wordt gereinigd, moet het uitgeschakeld worden en moet de stekker uit het stopcontact verwijderd worden. Laat de machine vervolgens afkoelen.

					
	×	✓	✓	×	×
	✓	×	×	✓	✓
	×	×	×	✓	✓
	×	×	×	✓	✓
	×	×	✓	✓	×
	×	×	×	✓	✓

8.1 Reiniging koffieuitloop



Als het lampje  (oranje) gaat branden, (B13), moet de reiniging van het koffiecircuit worden uitgevoerd. Voor de reinigingscyclus moeten reinigingstabletten voor koffiemachines worden aangeschaft. Ga voor meer informatie naar de website www.Delonghi.com.

1. Breng de filterzeef 1 kopje (C2) aan in de filterhouder (C1) (afb. 25).
2. Plaats het reinigingsaccessoire (C8) in de filterzeef (afb. 25) en druk stevig aan.
3. Plaats de reinigingstablet op het accessoire (afb. 26).
4. Breng de filterhouder aan op de koffieuitloop (A18).
5. Vul het waterreservoir (A14). Zorg ervoor dat het drupbakje (A10) leeg is.
6. Houd de toets  (B6) ingedrukt, tot het lampje  (B13) gaat branden. De reiniging wordt na enkele minuten automatisch onderbroken.
7. Verwijder de filterhouder en het reinigingsaccessoire.
8. Spoel de filterhouder en de filterzeef onder stromend water.
9. Plaats de filterhouder terug en laat een spoeling uitvoeren door te drukken op toets  : we raden aan een bakje onder de filterhouder te plaatsen.
10. Verwijder en ledig het drupbakje.

Opgelet:

Deze reinigingscyclus kan op elk moment gestart worden door de toets  enkele seconden ingedrukt te houden. Houd de toets gedurende 10 seconden ingedrukt als u de handeling wenst te annuleren.

8.2 Reiniging van het koffiebonenreservoir

1. Zorg ervoor dat het koffiebonenreservoir (A2) leeg is. Maal eventueel enkele keren, zonder koffiebonen toe te voegen, om het reservoir te ledigen.
2. Neem het reservoir weg uit de machine door het linksom te draaien (afb. 27)
3. Zuig de koffieresten op (afb. 28).
4. Reinig de zitting van het koffiebonenreservoir met een vochtige doek en droog daarna af (afb. 29);
5. Plaats het reservoir terug in de koffiemolen. Het reservoir is goed geplaatst als het pijltje  is uitgelijnd met het symbool  en er een "klik" wordt gehoord (afb.30).

8.3 Reiniging van het maalmechanisme

Bij de reiniging van het koffiebonenreservoir (A2), moeten ook de zitting van het reservoir en het bovenste maalmechanisme met een vochtige doek gereinigd worden. Neem voor de verwijdering en vervanging van het maalmechanisme contact op het een servicecentrum.

In geval de koffiemolen geblokkeerd raakt door een vreemd voorwerp, is het mogelijk om het maalmechanisme te verwijderen. Verwijder in dat geval het koffiebonenreservoir en handel als volgt:

1. Breng de filterhouder (C1) aan en maal eenmaal, zonder koffiebonen, om het traject van de koffie vrij te maken.
2. Schakel het apparaat uit.
3. Draai de regelknop van de maalgraad naar de uiterste stand "REMOVE" (afb. 31).
4. Trek het bovenste deel van het maalmechanisme uit door het vast te pakken bij de daarvoor bestemde greep (afb.32).
5. Reinig het maalmechanisme met een kwast (afb. 33) en zuig de koffieresten op met een stofzuiger (afb. 28).

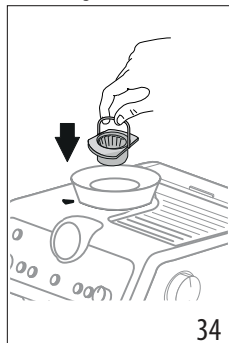
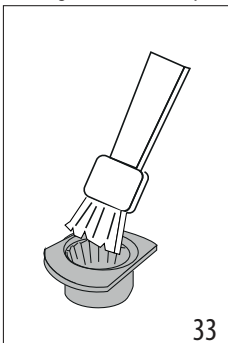

6. Plaats het maalmechanisme terug in zijn zitting (afb. 34);

7. Draai de regelknop en selecteer de gewenste maalgraad (afb. 14);

Controleer de correcte plaatsing van het maalmechanisme door aan de greep te trekken; een goed aangebracht maalmechanisme beweegt niet.

8.4 Het maalmechanisme vervangen

Neem, als de hoeveelheid gemalen koffie verder afneemt, contact op met een servicecentrum om het maalmechanisme te laten vervangen. Vervolgens moet de koffiemolen worden afgesteld: open menu instellingen ("7. Menu instellingen") en selecteer het eerste extra regelbereik van de maalgraad. Draai de regelknop van de hoeveelheid (B2) vervolgens naar stand MIN en pas de dosis aan zoals voor het eerste gebruik (zie "De "perfecte dosis"").

8.5 Reiniging van het "Smart tamping station"

1. Reinig het bevestigingsgebied met een kwast (afb. 35).
2. Trek de hendel (A20) tot aan het einde van zijn beweging en reinig de koffiestamper met een kwast (afb. 36); laat de hendel vervolgens los.
3. Reinig de koffiegoot met het ronde borsteltje (C7) (afb. 37).

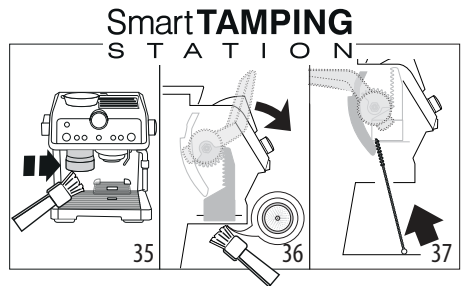

9. WATERHARDHEID

Het lampje  (B9) ontkalking gaat branden na een vooraf bepaalde periode van werking die afhankelijk is van de waterhardheid. Het is mogelijk om de machine te programmeren op basis van de werkelijke plaatselijke waterhardheid, zodat de ontkalking minder vaak uitgevoerd hoeft te worden.

1. Verwijder het meegeleverde reactiestrookje "TOTAL HARDNESS TEST" (C4) uit zijn verpakking.
2. Dompel het strookje ongeveer één seconde geheel onder in een glas water.
3. Neem het strookje uit het water en schud het lichtjes. Stel het apparaat in zoals beschreven in hoofdstuk "7. Menu instellingen".

Resultaat test waterhardheid	Toets	Niveau
	× 2	1 zacht water
	≡ 0°	2 middelhard water
	OK	3 hard of zeer hard water

- Stel het apparaat in zoals beschreven in hoofdstuk "7. Menu instellingen".

10. SOFTBALLS GEBRUIKEN

Softballs (C9) is een innovatief systeem dat de levensduur van de machine verlengt, zonder de kwaliteit van het water te wijzigen, en de afgifte van romige en geurende koffie garandeert. Om de doeltreffendheid ervan te verbeteren, moet Softballs voorafgaand aan het gebruik een hele nacht in het water gelaten worden.

- Neem het zakje Softballs uit de verpakking (afb. 38).

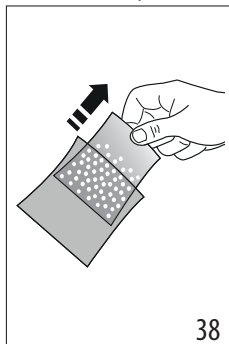

- Spoel het zakje Softballs onder stromend water (afb. 39).
- Dompel het zakje onder in het waterreservoir (A14) (afb. 40).

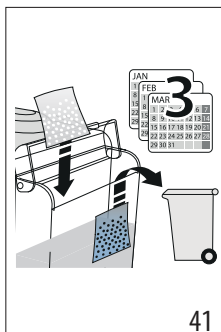
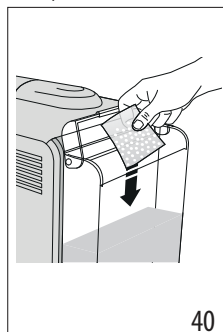

- Vervang het zakje Softballs om de 3 maanden (afb. 41).

11. ONTKALKING

Let op!

- Lees voorafgaand aan het gebruik de aanwijzingen en het etiket van de ontkalker (C5), zoals aangegeven op de verpakking van het product.
- Wij raden aan uitsluitend de ontkalker van De'Longhi te gebruiken. Het gebruik van ongeschikte ontkalkers, evenals het niet regelmatig uitvoeren van de ontkalking, kan leiden tot het optreden van gebreken die niet door de garantie van de fabrikant gedekt worden.
- De ontkalker kan kwetsbare oppervlakken beschadigen. Bij per ongeluk morsen van het product onmiddellijk opnemen en drogen.

Om de ontkalking uit te voeren

Ontkalker	Ontkalker De'Longhi
Bak	Inhoud 2 liter
Tijd	~40min

- (INDIEN AANWEZIG, HET VERZACHTINGSFILTER EN DE SOFTBALLS VERWIJDEREN). Giet de ontkalker in het waterreservoir (A14), tot aan niveau **A** (komt overeen met een verpakking van 100ml), aangegeven op de binnenkant van het reservoir (afb. 42).

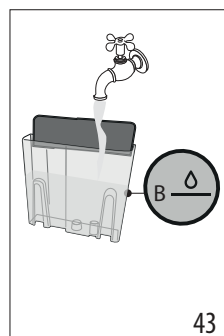
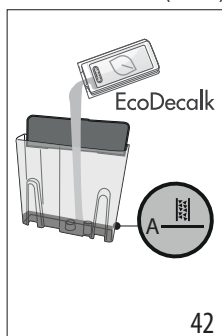

- Voeg water toe tot aan niveau **B** (afb. 43). Plaats het waterreservoir terug in de machine.

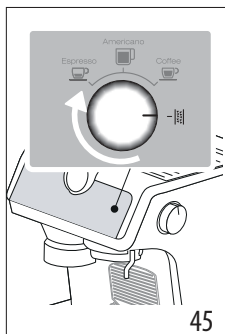
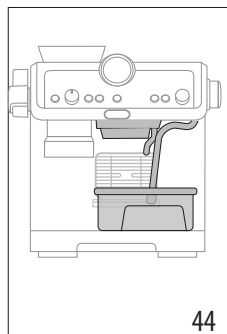

stromend water en vul het met vers water tot aan niveau MAX (afb. 46). Plaats het reservoir dan terug in zijn zitting.

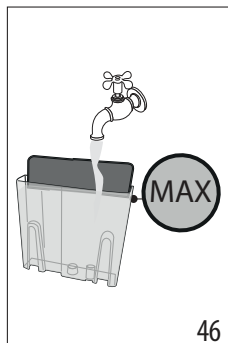

3. Zorg ervoor dat de filterhouder (C1) niet is aangebracht en plaats een bakje onder de uitlopen van koffie en heet water en onder het stoompijpe (A6) (afb. 44).
4. Draai de knop (B8) naar ☺☺☺ (afb. 45): het lampje OK wordt oranje verlicht en het lampje ☺☺☺ knippert.
5. Druk op de toets OK: het lampje OK knippert.
6. Het ontkalkingsprogramma wordt gestart en de ontkalkingsvloeistof stroomt uit de uitlopen. Het ontkalkingsprogramma voert automatisch, met tussenpozen, een reeks spoelingen uit om de kalkresten uit het koffiezetapparaat te verwijderen, tot het reservoir leeg is.

De afgifte stopt en het lampje OK wordt wit gekleurd. Vervolgens moet er een spoelcyclus worden uitgevoerd:

7. Maak de voor het opvangen van de ontkalkingsoplossing gebruikte bak leeg en plaats hem terug onder de uitlopen.
8. Verwijder het waterreservoir, verwijder de eventuele resten van ontkalkingsoplossing, spoel het reservoir af onder





9. Druk op de toets OK: de spoeling begint.
10. Na het voltooiën van de spoeling wordt de afgifte onderbroken en is het apparaat klaar voor gebruik.
11. Ledig de voor het opvangen van het spoelwater gebruikte bak.
12. Verwijder en ledig het drupbakje en plaats het terug.
13. Verwijder het waterreservoir, vul het met vers water en plaats het terug.

Het apparaat is nu klaar voor gebruik.









Opgelet:

- De cyclus voor ontkalking kan op elk gewenst moment gestart worden (ook als het betreffende lampje niet brandt).
- Mocht de ontkalking per ongeluk zijn gestart, houd de toets OK dan 10 seconden ingedrukt; de spoeling kan niet onderbroken worden.





12. BETEKENIS VAN DE LAMPJES

LAMPJES	BETEKENIS VAN DE LAMPJES	HANDELING
Alle lampjes knipperen kort	Inschakeling van het apparaat	Zelfdiagnose
 continu brandend	Het betreft de eerste inschakeling van de machine en het watercircuit moet gevuld worden	Ga te werk zoals beschreven in hfdst. "3. Eerste inwerkinstelling van het apparaat"
 continu brandend (wit)	De machine is klaar voor de afgifte	Bereid de machine voor en ga verder met het zetten van de drank
<ul style="list-style-type: none"> • Lampje : geeft de geselecteerde koffietemperatuur aan • Lampje : geeft aan dat de machine klaar is voor de afgifte van heet water 		



LAMPJES	BETEKENIS VAN DE LAMPJES	HANDELING
 continu brandend	De functie energiebesparing is actief	Verwijs voor de eventuele deactivering van de functie naar hfdst. "7. Menu instellingen"
 continu brandend	Het koffiebonenreservoir (A2) is leeg	Vul het koffiebonenreservoir
 knipperend	Er is geprobeerd koffie te malen, maar het koffiebonenreservoir (A2) is leeg	Vul het koffiebonenreservoir
 kort knipperend met regelmatige intervallen	De knop (B2) is gedraaid naar de stand voor maximale instelling 	Als de koffie in de filterzeef na het malen onvoldoende is, selecteer dan een nieuw maalniveau, zoals aangegeven in hoofdstuk "7. Menu instellingen".
 continu brandend	Het water in het reservoir (A14) is niet voldoende of het waterreservoir is niet goed geplaatst	Vul het reservoir of verwijder het en plaats het correct terug
 knipperend	Er is geprobeerd een drank te bereiden, maar het waterreservoir (A14) is leeg	Vul het waterreservoir
	De maalgraad is te fijn en de koffie loopt daardoor te langzaam of helemaal niet	Verwijder de filterhouder (C1) en herhaal de handelingen voor het zetten van koffie volgens de aanwijzingen van par. "4.1 Fase 1 - Malen (grinding)" en "4.2 Fase 2 - Aanstampen (tamping)"
	De filterzeef (C2) of (C3) is verstopt	Spoel de filterzeven af onder stromend water
	Het reservoir (A14) is niet goed geplaatst of de ventielen ervan zijn niet geopend	Druk het reservoir licht aan om de ventielen ervan te openen
 continu brandend	Kalk in het hydraulische circuit	Voer de ontkalking uit zoals beschreven in hfdst. "11. Ontkalking"
	Het apparaat is klaar voor de afgifte van stoom	Het apparaat heeft de temperatuur bereikt voor de afgifte van stoom. Voor de afgifte moet de stoomknop (A4) gedraaid worden
 knipperend	Het apparaat is ingeschakeld en de functie energiebesparing is actief: de stoomknop (A4) staat op de stand voor de afgifte van stoom	Het knipperende lampje geeft aan dat het apparaat zich voorbereid op de afgifte van stoom: de afgifte start zodra het apparaat op temperatuur is
	Het apparaat is klaar voor de afgifte van stoom	Het apparaat is op temperatuur voor de bereiding van stoom als het lampje continu brandt
	Het apparaat geeft stoom af	

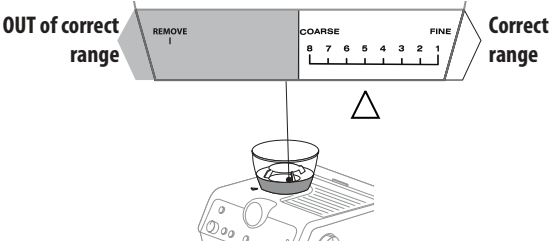



LAMPJES	BETEKENIS VAN DE LAMPJES	HANDELING
 continu brandend	Het koffiebonenreservoir is niet aangebracht	Plaats het koffiebonenreservoir (A2) of controleer de correcte plaatsing ervan. Het reservoir is goed geplaatst als het pijltje ▲ is uitgelijnd met het symbool  en er een "klik" wordt gehoord
 knipperend	De regeling van de knop van de maalgraad is onjuist of voorbij de maximaal mogelijke instelling	Breng de keuzeschakelaar naar één van de standen voor malen (van 1 tot 8) en denk eraan: <ul style="list-style-type: none"> • De maalgraad moet worden afgesteld tijdens de werking van de koffiemolen • Pas één niveau per keer aan en maal ten minste 5 keer tussen de verschillende aanpassingen
		
 continu	Het apparaat vraagt de koffie aan te stampen	Er is net koffie gemaalend en de filterhouder is aangebracht op de koffiemolen
	De filterhouder werd zonder aan te stampen losgekoppeld van de koffiemolen	Koppel de filterhouder los en stamp de koffie aan zoals beschreven in par. "De "perfecte dosis"" "In geval van gebruik van voorgemalen koffie:"
	De filterhouder is losgekoppeld zonder dat de maling was voltooid of het aanstampen is te vroeg uitgevoerd	Herhaal de maling
	De koffiegoot van de koffiemolen is verstopt	Voer de reiniging uit zoals beschreven in par. "8.5 Reiniging van het "Smart tamping station"". Als het probleem aanhoudt, open dan het luikje om de koffiegoot te bereiken en reinig de goot met het ronde borsteltje
	Het maalmechanisme is geblokkeerd door een vreemd voorwerp	Verwijder het vreemde voorwerp en reinig het maalmechanisme zoals aangegeven in par. "8.3 Reiniging van het maalmechanisme".
 continu brandend (rood)	De ontkalking moet worden uitgevoerd	Voer de ontkalking uit zoals aangegeven in hfdst. "11. Ontkalking"



LAMPJES	BETEKENIS VAN DE LAMPJES	HANDELING
 knipperend (rood) +  knipperend (oranje)	Het apparaat is de ontkalking aan het uitvoeren	Ga verder met de handeling volgens de beschrijvingen van hfdst. "11. Ontkalking"
 knipperend (rood) +  continu brandend (wit)	De spoeling moet worden uitgevoerd	
 knipperend (rood) +  knipperend (wit)	Het apparaat is de spoeling van de ont- BUITEN het uitvoeren bereik	Bereik correct
 continu brandend (oranje)	De kop moet gereinigd worden	
 knipperend (oranje)	Het apparaat is de reiniging van de koffieuitloop aan het uitvoeren	
Alle lampjes knipperen	Algemeen alarm	Neem contact op met een servicecentrum

13. ALS ER IETS NIET WERKT

PROBLEEM	OORZAAK	OPLOSSING
Er is water aanwezig in het drupbakje (A10)	Dit maakt deel uit van de normale werking van de interne circuit van de machine	Ledig en reinig het drupbakje regelmatig
Er wordt geen espresso afgegeven	Geen water in het reservoir (A14)	Vul het waterreservoir
	Het lampje  (B6) brandt om aan te geven dat het koffie- of stoomcircuit leeg is	Druk op de toets van het lampje  om het circuit te vullen
	De filterzeef (C2) of (C3) is verstopt	Spoel de filterzeven af onder stromend water
	Het reservoir (A14) is niet goed geplaatst en de ventielen op de bodem ervan zijn niet geopend	Druk het reservoir licht aan om de ventielen op de bodem te openen
	Kalk in het hydraulische circuit	Voer de ontkalking uit zoals beschreven in hfdst. "11. Ontkalking"
	Te fijne maalgraad	Verwijder de filterhouder (C1) en herhaal de handelingen voor het zetten van koffie volgens de aanwijzingen van par. "4.1 Fase 1 - Malen (grinding)" en "4.2 Fase 2 - Aanstampen (tamping)"
De filterhouder kan niet op het apparaat bevestigd worden	De gemalen koffie is niet aangestampt of de filterhouder bevat te veel koffie	Herhaal de maling met andere instellingen. Verminder de hoeveelheid koffie: controleer of de filterzeef (C2) of (C3) (1 of 2 kopjes) correct zijn ten opzichte van de te malen dosis (toets 2x (B3) wel of niet geselecteerd)
		→

PROBLEEM	OORZAAK	OPLOSSING
De espressokoffie druppelt over de rand van de filterhouder (C1) in plaats van door de gaatjes	De filterhouder is niet goed geplaatst	Bevestig de filterhouder correct en draai hem stevig tot aan de uiterste stand vast
	De pakking van de koffieuitloop (A18) is niet langer elastisch of is vuil	Laat de pakking van de koffieuitloop vervangen door een servicecentrum
	De filterzeef (C2) of (C3) is verstopt	Spoel de filterzeven af onder stromend water
De crème van de koffie is licht van kleur (de koffie stroomt snel uit de tuitjes)	De instellingen van het apparaat moeten gecontroleerd worden	Verwijder de filterhouder en herhaal de handelingen voor het zetten van koffie volgens de aanwijzingen van par. "4.1 Fase 1 - Malen (grinding)" en "4.2 Fase 2 - Aanstampen (tamping)"
De crème van de koffie is donker (de koffie stroomt langzaam uit de tuitjes)	De instellingen van het apparaat moeten gecontroleerd worden	Verwijder de filterhouder (C1) en herhaal de handelingen voor het zetten van koffie volgens de aanwijzingen van par. "4.1 Fase 1 - Malen (grinding)" en "4.2 Fase 2 - Aanstampen (tamping)"
Na het voltooien van de ontkalking vereist het apparaat nog een spoeling	Tijdens de ontkalking is het reservoir niet tot aan het niveau MAX gevuld	Herhaal de spoeling (zie hfdst. "11. Ontkalking")
Het apparaat maalt de koffie niet	Een vreemd voorwerp in de koffiemolen	Reinig de maalmechanismen zoals beschreven in par. "8.3 Reiniging van het maalmechanisme", en zorg ervoor dat alle koffiebonen uit het koffiebonenreservoir (A2) zijn verwijderd voordat het reservoir wordt weggenomen. Voorafgaand aan de terugplaatsing moeten alle resten zorgvuldig uit de zitting van het reservoir worden opgezogen
	Het koffiebonenreservoir (A2) is niet correct geplaatst	Het reservoir is goed geplaatst als het pijltje ▲ is uitgelijnd met het symbool  en u een "klik" hoort
→		

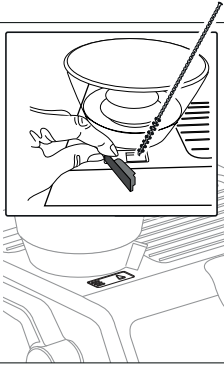
PROBLEEM	OORZAAK	OPLOSSING
Als u het type koffie wenst te wijzigen	Alle in de machine aanwezige koffiebonen moeten verwijderd worden	<ul style="list-style-type: none"> • Maak het koffiebonenreservoir (A2) leeg (door te malen zonder koffiebonen toe te voegen of door de resterende bonen op te zuigen) • Breng de filterhouder (C1) aan en maal een paar keer zonder koffiebonen toe te voegen om het kanaal van de gemalen koffie vrij te maken: bevestig de filterhouder vervolgens op de uitloop van de koffiemolen (A19), uitgelijnd met het opschrift INSERT, en draai de houder naar rechts. De maling start wanneer de houder de stand CLOSE bereikt en wordt automatisch onderbroken. Herhaal tot de filterhouder leeg blijft • Voeg de nieuwe kwaliteit koffie toe aan het koffiebonenreservoir (A2) • Als met de maling niet de “perfecte dosis” wordt verkregen, ga dan te werk zoals voor het eerste gebruik
Na het malen is de filterzeef (C2) of (C3) leeg	De koffiegoot van de koffiemolen is verstopt	Voer de reiniging uit zoals beschreven in par. “8.5 Reiniging van het “Smart tamping station””. Als het probleem aanhoudt, open dan het luikje (A21) om de koffiegoot te bereiken en reinig de goot met het ronde borsteltje
Na de maling bevat de filterzeef te veel koffie		
→		

PROBLEEM	OORZAAK	OPLOSSING
Na de maling bereikt de gemalen koffie in de filterzeef (C2) of (C3) niet de "perfecte dosis"	Het "Smart Tamping Station" moet gereinigd worden	Voer de reiniging uit zoals beschreven in par. "8.5 Reiniging van het "Smart tamping station"", en herhaal vervolgens de maling
	De hoeveelheid gemalen koffie moet worden aangepast	Regel de hoeveelheid met de daarvoor bestemde knop (B2) en volgens de aanwijzingen van par. "De "perfecte dosis"". Als de knop al op stand max staat, ga dan te werk zoals aangegeven onder paragraaf "7. Menu instellingen" - "Extra instelling van de maalgraad"
	Het maalmechanisme zal na verloop van tijd verslijten	Vervang het maalmechanisme zoals aangegeven in par. "8.4 Het maalmechanisme vervangen"

Antes de utilizar el aparato lea siempre el folleto en que figuran las advertencias de seguridad.

1. DESCRIPCIÓN

1.1 Descripción del artefacto - A

- A1. Tapa del recipiente de granos
- A2. Recipiente de granos
- A3. Bandeja de tazas
- A4. Marcación de vapor
- A5. Salida de agua caliente
- A6. Varilla y boquilla de vapor
- A7. Rejilla de taza para espresso
- A8. Rejilla para vasos o tazones
- A9. Rejilla de la bandeja de goteo
- A10. Bandeja de goteo
- A11. Indicador de nivel de agua bandeja de goteo
- A12. Tapa del depósito de agua
- A13. Asa de extracción del depósito de agua
- A14. Depósito de agua
- A15. Alojamiento filtro ablandador
- A16. Enchufe del cable de alimentación
- A17. Interruptor principal (ON/OFF)
- A18. Salida del café
- A19. Salida del molino de café (tamping station)
- A20. Palanca de presión
- A21. Tapa para acceder al molino de café guía del café

1.2 Descripción del panel de control - B

- B1. Botón ON/Standby
- B2. Marcación de la dosis de café
- B3. Botón "X2": para usar el filtro de 2 cafés
- B4. Botón de la temperatura del café
- B5. Botón "OK": para suministrar bebida/confirmar
- B6. Botón agua caliente
- B7. Botón "My": para personalizar la cantidad de la bebida
- B8. Marcación selector de bebida
 - Espresso
 - Americano
 - Coffee
 - Descalcificación
- B9. Luz "Descalcificación"
- B10. Luz "vapor listo"
- B11. Luz "Sin recipiente de granos"
- B12. Luz "Ahorro de energía"
- B13. Luz "limpieza" (véase "8.1 Limpieza de la salida del café")
- B14. Luz "recipiente de granos vacío"
- B15. Luz "Sin agua"
- B16. Indicador prensado
- B17. Manómetro

1.3 Descripción de los accesorios - C

- C1. Portafiltro
- C2. Filtro 1 taza de café
- C3. Filtro 2 tazas de café
- C4. Papel indicador "Prueba de dureza del agua"
- C5. Descalcificador
- C6. Cable de alimentación extraíble
- C7. Cepillo de tubo
- C8. Accesorio del disco de limpieza de la salida del café
- C9. Softballs
- C10. Jarra de leche
- C11. Aguja de limpieza para la boquilla de vapor

1.4 Accesorios de limpieza opcionales recomendados

Visite Delonghi.com para más información.



Tableta de limpieza

(véase "8.1 Limpieza del surtidor de café")

EcoMultiClean Detergente

EAN: 8004399333307

2. PREPARAZIONE DELL'APPARECCHIO

Lave con agua tibia y detergente para vajillas todos los accesorios, después proceda de la siguiente manera:

1. Vuelva a colocar el recipiente (A2) introduciéndolo en el molinillo (fig. 1). El recipiente está bien colocado cuando la flecha ▲ está alineada con el símbolo ☐ y se escucha un "clik" (fig. 2).
2. Introduzca la bandeja de goteo (A10) completa con la rejilla de tazas (A8) y la rejilla de la bandeja de goteo (A9) (fig. 3);
3. Saque el depósito de agua a (A14) (fig. 4) y llénalo con agua fresca y limpia sin superar el mensaje MÁX (fig. 5).
4. A continuación vuelva a meter el depósito

Atención: No ponga nunca en funcionamiento el aparato sin agua en el depósito o sin depósito.

Nota Bene: Le aconsejamos personalizar cuanto antes la dureza del agua, para ello siga el procedimiento descrito en el capítulo "7. Menú configuraciones".

3. PRIMERA PUESTA EN FUNCIONAMIENTO DEL APARATO

1. Introduzca el conector del cable de alimentación (C6) en su soporte (A16), situado en la parte posterior del aparato (fig. 6); a continuación meta la clavija en la toma. Asegurándose que el interruptor general (A17), que se encuentra en la parte posterior del aparato esté pulsado en la posición I (fig. 7);
2. Coloque un recipiente con una capacidad mínima de 100 ml debajo del pico del agua caliente (fig. 8);
3. Pulse ☐ (B6) (fig. 9): la salida comienza y se interrumpe automáticamente. Vacíe el recipiente.

Antes de empezar a utilizar la cafetera es necesario enjuagar sus 74 circuitos internos. Proceda de la siguiente manera:

- Enganche la copa portafiltro (C1) con el filtro a la máquina para un enganche correcto; alinee el asa de la copa portafiltro a «INSERT» (fig. 10) y gire el asa hacia la derecha, hasta alinearla a la posición «CLOSE»;
- Meta un recipiente debajo de la copa portafiltro y del capuchinador (A6);
- Pulse el botón OK (B5) (fig. 11): empieza la salida;
- Una vez terminada la salida, gire el botón vapor (A4) (fig. 12) y deje salir el vapor durante 10 segundos para enjuagar el circuito vapor: para un rendimiento óptimo del vapor, le recomendamos que repita esta acción 3 o 4 veces. Esto es para purgar el vapor antes de espumar o vaporizar la leche.

El aparato está listo para el uso.

Nota Bene: se aconseja enjuagar los circuitos internos también en caso de que no se use el aparato durante un tiempo prolongado.

Quando utilice por primera vez la cafetera, será necesario preparar 4-5 cafés antes de obtener buenos resultados: dedique atención especial a la dosis de café molida en el filtro ((C2) ou (C3)) (éanse las instrucciones en el apartado “4.1 Fase 1 - Molienda (grinding)”).

Proceda tal y como indicado en el capítulo “La “dosis perfecta””.

4. PREPARAR EL CAFÉ

4.1 Fase 1 - Molienda (grinding)

- Vierta los granos en el recipiente (A2) (fig. 13). Se recomienda verter solo los granos necesarios para la preparación: de este modo se utilizará siempre café fresco;
- Seleccione el grado de molienda (fig. 14). La configuración de fábrica es 5 (molienda media). Si el resultado no fuera satisfactorio, regule el nivel en base al gusto personal y al tipo de café (la regulación debe realizarse durante el funcionamiento del molinillo).

Nota bene: Se recomienda el ajuste de molido entre 3y6 para la mayoría de los cafés. El resultado de la molienda con selección en 1 o 2, es muy fino, para ser utilizado solo con café muy particular (tostado ligero).

- Introduzca uno de los filtros de café (C2) ou (C3) en el portafiltro (C1) (fig. 15). Si se utiliza el filtro para 2 tazas, pulse el botón X2 (B3): con esta selección se dobla también la cantidad suministrada de espresso.
- Regule el botón cantidad (B2) partiendo de la posición mínima (fig. 16).

Véanse las instrucciones en el apartado “Regule la cantidad de café molido en el filtro”.

- Enganche el portafiltro a la salida del molinillo (A19) alineándolo con el mensaje INSERT: a continuación gire hacia la derecha la copa. La molienda inicia cuando la copa alcanza la posición CLOSE y se interrumpe automáticamente.

Regule la cantidad de café molido en el filtro

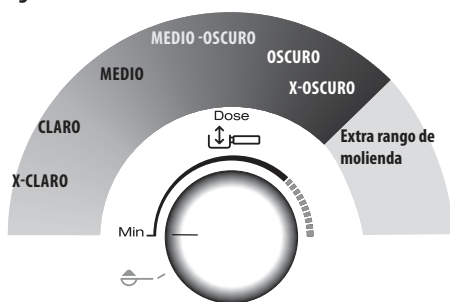

Cada variedad de grano da un resultado diverso durante la molienda y por esto al inicio la regulación de la dosis requiere cuidado extremo.

Esta ilustración da las indicaciones sobre cómo regular la dosis, basadas en el color del tostado: se deben considerar un punto de partida, pero pueden variar en base a la composición de los granos de café.

- Configure la dosis desde la posición mínima.
- Haciendo referencia al color del tostado de su café, gire lentamente el botón.

4.2 Fase 2 - Prensado (tamping)

- Después de la molienda, baje la palanca de prensado (A20) hasta final de carrera (no quite el portafiltro) (fig. 17). Para un resultado perfecto, repítalo 2 veces.
- Mantenga bajada la palanca hasta el final de carrera durante la remoción del portafiltro (fig. 18). Para regresar la palanca a la posición inicial.
- Una vez verificada que la dosis de cafés sea correcta (vedi “La “dosis perfecta””), enganche el portafiltro al surtidor del café (A18) (fig. 19).

Nota bene: Si después del prensado queda algún residuo de café en los bordes del filtro, esto no afecta en modo alguno a la calidad de la extracción y por tanto al resultado final.

La “dosis perfecta”

- Los filtros de café tienen un marcado interno para identificar el nivel para la dosis perfecta.

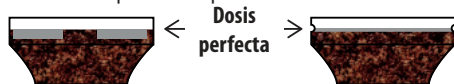

Marcado con laser

- Filtro con marcado con laser: la dosis perfecta corresponde a la línea superior del marcado.
- Filtro con marcado en relieve: la dosis perfecta corresponde a la línea en relieve.

Marcado en relieve









- Asegúrese de que el café esté al nivel después del prensado. Podría ser necesario regular el botón más veces (B2) antes de llegar a la dosis perfecta.
- Si el café está sobre- o bajo-extraído y la dosis está dentro de la dosis perfecta, regule el grado de molienda más fino o más grueso (véase “4.1 Fase 1 - Molienda (grinding)”). Si el café está sobre- extraído (suministro demasiado lento) la molienda deberá ser más gruesa. Si el café está bajo-extraído (suministro demasiado rápido) la molienda deberá ser más fina.
- **El barman aconseja:** Saque el portafiltro mientras la palanca del prensador (A20) está bajada para obtener un acabado perfecto de la dosis de café.
- **Cuando se usa café premolido:**
 - llenar el filtro con café premolido
 - girar el marcación de la dosis de café hasta ;
 - conecte el portafiltro;
 - hale la palanca hacia abajo

4.3 Fase 3 - Suministro (brewing)

1. Seleccione la temperatura (fig. 20) (vedi “4.4 Ajustar la temperatura”).
2. Seleccione la bevanda desiderata (fig. 21).
3. Pulse OK (B5) para iniciar el suministro (fig. 11) (pre-infusión e infusión). El suministro del café se interrumpe automáticamente.

4.4 Ajustar la temperatura

La temperatura del agua se controla con precisión durante todo el proceso de elaboración para garantizar la estabilidad de temperatura ideal para la extracción. La Specialista Prestigio ofrece hasta 3 perfiles de temperatura de infusión * para seleccionar, correspondientes a un rango de temperaturas entre 92 ° y 96 ° C. Las variedades de granos de café y los colores de tostado requieren su propio ajuste de temperatura específico para obtener la mejor extracción: los granos de café robusta prefieren una temperatura más baja; Arábica prefiere temperaturas más altas. Lo mismo se aplica a los granos de color tostado más oscuro o a los granos recién tostados que los desgasificados con el tiempo.

Nivel de la temperatura	Luz correspondiente	Nivel de tostado de café
MIN	   	Oscuro
MED	   	Medio-oscuro

MAX	   	Claro-medio
------------	---	--------------------

- * Esta temperatura se refiere al agua dentro del termobloque. Esto difiere de la temperatura de la bebida en la taza o de la temperatura medida cuando la bebida sale por las boquillas del portafiltro.

5. PREPARACIÓN DE BEBIDAS A BASE DE LECHE

5.1 Espumar la leche

1. Vierta en el recipiente de la leche (C10) la cantidad de leche que se desea calentar/espumar, teniendo en cuenta que el volumen de la leche aumentará 2 o 3 veces (fig. 22). Para obtener una espuma más densa y homogénea, se recomienda utilizar leche entera de vaca y a temperatura de la heladera (aproximadamente 5° C).

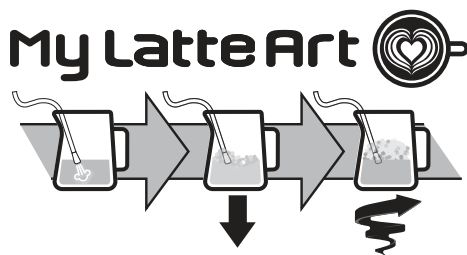

2. Para espumar la leche, apoye el tubo de salida del vapor (A6) en la superficie de la leche: haciendo esto el aire se mezcla con la leche y el vapor.
3. Mantenga el tubo de salida de vapor en la superficie, prestando atención a no capturar demasiado aire creando burbujas demasiado gruesas.
4. Sumerja el tubo de salida de vapor bajo la superficie de la leche: de este modo se crea un vórtice. Una vez alcanzada la temperatura deseada, vuelva a cerrar el botón de vapor y espere a que el suministro de vapor se interrumpa completamente antes de quitar la jarra de leche.

El barman aconseja:

- **Il latte fresco è migliore.** Utilizzare sempre latte fresco a temperatura di frigorifero.
- Para obtener mejores resultados, guarde la jarra de leche en el refrigerador.
- La leche entera asegura resultados óptimos. El resultado y la textura de la espuma varían de acuerdo a la leche de vaca o de las bebidas vegetales utilizadas.
- Después de haber espumado la leche, elimine las burbujas agitando la jarra de la leche.

Limpieza del surtidor de vapor:

- Después de cada uso, remueva con un paño los residuos de leche del surtidor de vapor (fig. 23). Para una limpieza profunda, se recomienda utilizar Eco MultiClean: asegura la higiene removiendo proteínas y grasas de la leche y puede utilizarse para limpiar toda la máquina.
- Suministre vapor por algunos segundos para limpiar bien el surtidor (fig. 12).
- Espere hasta que el surtidor se enfríe: para mantener la eficiencia del surtidor en el tiempo, utilice la aguja de limpieza (C11) para mantener libres los 3 orificios (fig. 24).

6. PERSONALICE LA LONGITUD DE LAS BEBIDAS DE CAFÉ CON EL BOTÓN (my) (B7)





- Prepare la cafetera para hacer 1 o 2 tazas de la bebida café que desee, hasta enganchar el portafiltro (C1) con el filtro (C2) o (C3) el café molido.
- Gire el botón (B8) para seleccionar la bebida a programar.
- Pulse la tecla (my): la spia correspondiente al tasto (my) lampeggia.
- Premerre il tasto OK per iniziare l'erogazione. El indicadores corrispondentse a las teclas OK y (my) parpadean.
- Una vez alcanzada la cantidad deseada, pulse OK. Si la bebida prevé el suministro de otro ingrediente, comienza el suministro de este último: una vez alcanzada la cantidad deseada, pulse OK.



- Pulse la tecla (my) para guardar. El aparato está listo para un nuevo uso y el indicador (my) permanece encendido.

Si no se desea guardar la programación, pulse cualquier otra tecla.

Nota bene:



- Se pueden programar las bebidas con café, pero no el suministro de vapor y agua caliente.
- La programación modifica las cantidades de las bebidas, pero no del café molido.
- Las bebidas "X2" pueden programarse separadamente.
- Para regresar a las configuraciones de fábrica, mantenga pulsada la tecla (my) hasta el apagado. La bebida seleccionada regresa a la cantidad de fábrica.**

Receta de café	Cantidad de fábrica	Cantidad programable
 Espresso	35 ml	de 25 a 90 ml
 Espresso X2	70 ml	de 50 a 180 ml
 Coffee	80 ml	de 50 a 120 ml
 Coffee X2	160 ml	de 120 a 240 ml

Receta de café	Cantidad de fábrica	Cantidad programable
 Americano	120 ml	<ul style="list-style-type: none"> espresso: de 25 a 60 ml acqua: de 25a 120 ml
 Americano X2	240 ml	<ul style="list-style-type: none"> espresso: de 50 a 120 ml acqua: de 50 a 240 ml

7. MENÚ CONFIGURACIONES

1. Entre en el menú:		
Pulse contemporáneamente por 5 segundos	x2	(my)
1. Seleccione el ajuste con la perilla (B8)		
		
Configuración correspondiente	Bebida	Regulaciones
Regulación extra el grado de molienda	 Espresso	x2 → Rango 1
		☰ → Rango 2
Dureza del agua	 Americano	x2 → blanda
		☰ → media
		OK → dura/muy dura
Autoapagado	 Coffee	x2 → 9 minutos
		☰ → 1,5 horas
		OK → 3 horas
1. Seleccione el ajuste con botón		
Ahorro energético	 → Activo	
	 → Apagado	
→		

Valor fábrica	Mantenga pulsada por al menos 5 segundo el botón  , hasta que el indicador permanece encendido fijo
2. Guarde las nuevas configuraciones pulsando ON/Standby (B1)	
 	

8. LIMPIEZA DEL APARATO









Attenzione!







¡Atención!

- Para limpiar la cafetera no use disolventes ni detergentes abrasivos, ni alcohol.
- No utilice objetos metálicos para eliminar las incrustaciones o los depósitos de café porque podrían rayar las superficies metálicas o plásticas.
- Para periodos de inutilización superiores a una semana se recomienda, antes de utilizar la máquina, proceder a un enjuague.

¡Peligro!



- No sumerja la máquina en el agua durante la limpieza: es un aparato eléctrico.
- Antes de cualquier operación de limpieza de las partes externas del aparato apague la cafetera quitando la clavija de la toma de corriente y deje enfriar la máquina.

					
	×	✓	✓	×	×
	✓	×	×	✓	✓
	×	×	×	✓	✓
	×	×	×	✓	✓
→					

					
	×	×	✓	✓	×
	×	×	×	✓	✓

8.1 Limpieza del surtidor de café

Quando el indicador  se enciende (naranja) (B13), es necesario proceder a la limpieza del circuito café. Para realizar el ciclo de limpieza, compre las pastillas para la limpieza de máquinas de café. Para más información, visite www.Delonghi.com.

1. Introduzca el filtro 1 taza (C2) en el portafiltro (C1) (fig. 25).
2. Introduzca en filtro el accesorio de limpieza (C8) (fig. 25) ey presiónelo hasta el fondo.
3. Meta la pastilla para la limpieza en el accesorio (fig. 26).
4. Conecte el portafiltro al surtidor de café (A18).
5. Llne el depósito del agua (A14). Asegúrese de que la bandeja recogegotas (A10) esté vacía.
6. Mantenga pulsada la tecla  (B6), hasta que el indicador  (B13) comienza a parpadear (naranja). Después de algunos minutos, la limpieza se interrumpe automáticamente.
7. Rimuovere il portafiltro e l'accessorio pulizia.
8. Lave el portafiltro y el filtro bajo agua corriente.
9. Vuelva a colocar el y proceda con un enjuague pulsando la tecla  : se recomienda colocar un recipiente debajo del portafiltro.
10. Quite y vacíe la bandeja recogegotas.

Nota Bene:

Este ciclo de limpieza puede ponerse en marcha en cualquier momento pulsando la tecla  por unos segundos. Para cancelar la operación, pulse el botón por 10 segundos.

8.2 Limpie al alojamiento del recipiente del café en granos

1. Asegúrese de que el recipiente del café en granos (A2) esté vacío. Eventualmente proceda con algunas moliendas al vacío para vaciarlo.
2. Desenganche el recipiente girándolo en sentido antihorario y sáquelo de la máquina (fig. 27)
3. Aspire los residuos de café (fig. 28).
4. Limpie con un paño húmedo el lugar del recipiente del café en granos y séquelo (fig. 29);
5. Limpie con un paño húmedo el lugar del recipiente del café en granos y séquelo (fig.30).

8.3 Limpieza de las muelas

Cuando se limpia el recipiente del café en granos (A2), limpie el soporte del recipiente y la muela superior con un paño húmedo. Diríjase a un centro de asistencia para quitar y cambiar las muelas. Es posible quitar la muela en el caso de que el molinillo estuviera bloqueado por un cuerpo extraño. Si esto sucede quite el recipiente del café en granos y proceda de la siguiente manera:

1. Enganche la copa portafiltro (C1) y haga una molienda "al vacío" para liberar el conducto del café.
2. Apague el aparato.
3. Gire en sentido antihorario el regulador de molienda hasta el final de carrera, a la posición "REMOVE" (fig. 31).
4. Extraiga la parte superior de la muela, agarrándola por la respectiva asa (fig.32).
5. Limpie la muela con una brocha (fig. 33) y aspire los residuos de café con un aspirador (fig. 28).

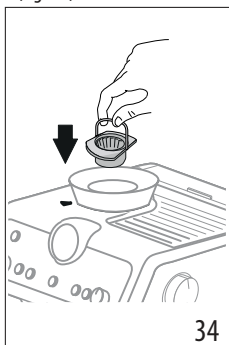
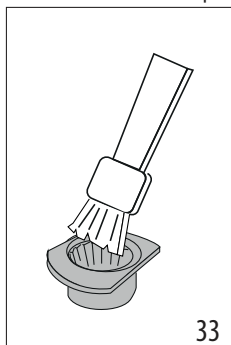

6. Meta la muela en su soporte (fig. 34);
7. Gire el regulador seleccionando el grado de molienda deseado (fig. 14);

Verifique si la máquina está bien metida tirando de ella por el asa: si no se mueve, significa que la muela está bien metida.

8.4 Sustitución de las muelas

Cuando la cantidad de café molido se reduce aun mas, diríjase a un centro de asistencia para cambiar las muelas: después regule de nuevo el molinillo entrando en el menú configuraciones ("7. Menú configuraciones") y seleccionando el primer rango de la regulación extra del grado de molienda. Luego, gire el botón regulación cantidad (B2) a posición MÍN y regule la dosis como en el primer uso (véase "La "dosis perfecta"").

8.5 Limpieza de la "Smart tamping station"

1. Limpie la zona de enganche con un pincel (fig. 35).
2. Tire la palanca (A20) hasta final de carrera y limpie con un pincel el prensador (fig. 36), luego suelte la palanca.
3. Limpie la rampa de café con el cepillo (C7) (fig. 37).

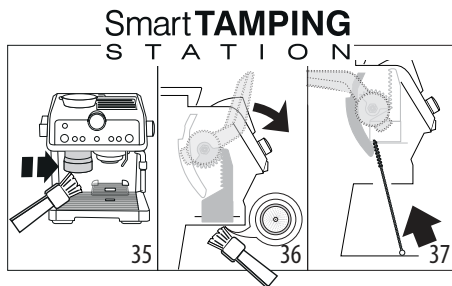

9. DUREZA AGUA

El indicador (B9) descalcificación se enciende después de un periodo de funcionamiento predeterminado que depende de la dureza del agua. Si lo desea, es posible programar la máquina en función de la dureza real del agua de las diferentes regiones, de esta forma la operación de descalcificación será menos frecuente.

1. Saque de su envase la tira suministrada «TOTAL HARDNESS TEST» (C4).
2. Immergere completamente la striscia in un bicchiere d'acqua per circa un secondo.
3. Saque la tira del agua y sacúdala ligeramente. Configure el aparato, como se indica en el capítulo "7. Menú configuraciones".

Resultado Prueba Dureza del Agua	Botón	Nivel
	×2	1 agua dulce
	≡	2 agua media
	OK	3 agua dura o muy dura

4. Configure el aparato, como se indica en el capítulo "7. Menú configuraciones".

10. CÓMO UTILIZAR SOFTBALLS

Softballs (C9) es un sistema innovador que prolonga la vida de la máquina, sin alterar las cualidades del agua, garantizando el suministro de un café cremoso y aromático. Para optimizar la eficacia, deje Softballs en el agua toda la noche antes del uso.

1. Saque el paquete de Softballs del empaque (fig. 38).

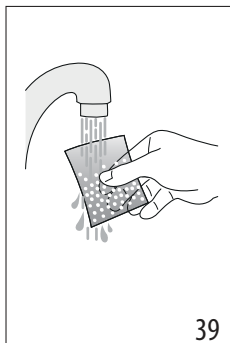
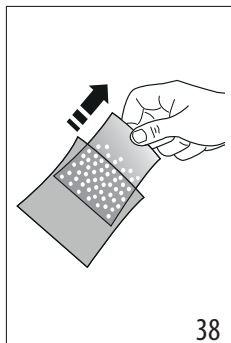

2. Enjuague con agua corriente el paquete de Softballs (fig. 39).
3. Sumerja la bolsa en el depósito de agua (A14) (fig. 40).

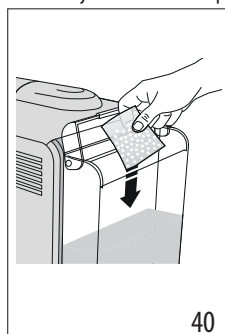

4. Sustituya la bolsa de Softballs cada 3 meses (fig. 41).

11. DESCALCIFICACIÓN

¡Atención!

- Antes del uso, lea las instrucciones y las etiquetas del descalcificador (C5), que figuran en su embalaje.
- Se recomienda usar solo descalcificador De'Longhi. El uso de descalcificadores no idóneos, como también la descalcificación no realizada regularmente, puede comportar la aparición de defectos no cubiertos por la garantía.
- El descalcificador puede dañar superficies delicadas. Si el producto se derrama accidentalmente, secar inmediatamente.

Para efectuar la descalcificación	
Descalcificador	Descalcificador De'Longhi
Recipientes	de 2 litros
Tiempo	~40min

1. (SI LO HAY, QRITE EL FILTRO ABLANDADOR Y LAS SOFT-BALLS). Vierta en el depósito de agua (A14) el descalcifica-

dor hasta el nivel A (correspondiente a un embalaje de 100ml) impreso del lado interno del depósito (fig. 42).

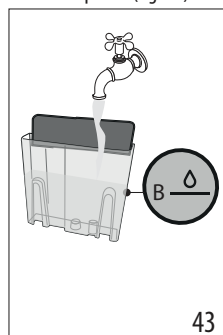
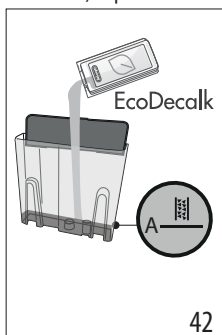

2. Agregue agua hasta alcanzar en nivel B (fig. 43). Vuelva a meter el depósito de agua en la máquina.

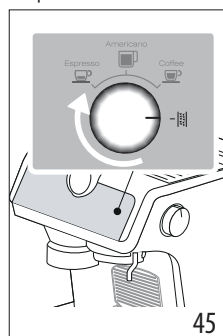
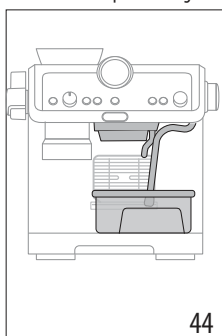

3. Asegúrese de que el portafiltro (C1) no esté enganchado y coloque un recipiente debajo de los surtidores de café y agua caliente y debajo del surtidor de café (A6) (fig. 44).
4. Gire el selector de funciones (B8) a la posición (fig. 45): el indicador luminoso OK se enciende naranja y el indicador luminoso parpadea.
5. Pulse OK: el indicador luminoso OK parpadea.
6. El programa de descalcificación comienza y el líquido descalcificador sale de los surtidores. El programa de descalcificación realiza automáticamente una serie de enjuagues a intervalos para eliminar los residuos de cal del interior de la cafetera hasta vaciar por completo el depósito. El suministro se interrumpe y el indicador OK se pone blanco. Luego es necesario proceder con el ciclo de enjuagado:
7. Vacíe el recipiente utilizado para recoger el líquido descalcificador y póngalo bajo los surtidores.
8. Saque el depósito del agua, vacíelo de los eventuales residuos de solución descalcificadora, enjuáguelo con agua corriente y llénelo con agua fresca hasta el nivel MÁX (fig. 46). Vuelva a meter el depósito en su soporte.

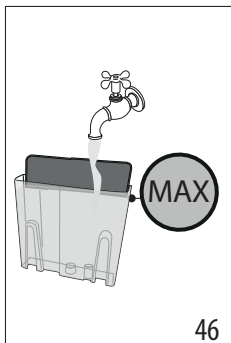

9. Pulse OK: el enjuague se pone en marcha.











10. Una vez completado el enjuague, el suministro se interrumpe y el aparato está listo para el uso.
11. Vacíe los recipientes de recogida del agua del enjuague.
12. Saque y vacíe la bandeja recogegotas y vuelva a meterla después.
13. Saque y llene el depósito con agua fresca, vuelva a meterlo después.

El aparato está listo para el uso.





Nota bene:







- El ciclo de descalcificación se puede ejecutar en cualquier momento;
- En caso de que inicie el ciclo de descalcificación por error, puede presionar el botón OK durante 10 segundos; el ciclo de enjuague no se puede detener



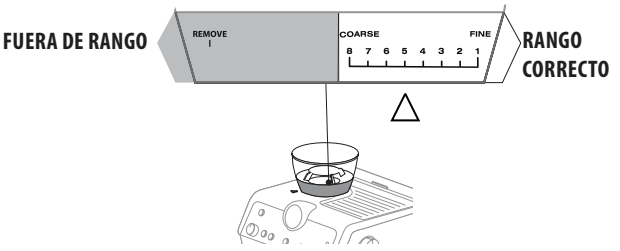

12. SIGNIFICADO DE LOS INDICADORES

INDICADORES	SIGNIFICADO DE LOS INDICADORES	OPERACIÓN
Todos los indicadores luminosos parpadean brevemente	Encendido del aparato	Autodiagnóstico
 fija	Es el primer encendido de la máquina y es necesario llenar el circuito de agua	Proceda como se indica en el cap. "3. Primera puesta en funcionamiento del aparato"
 fija (blanca) • Indicador  : nivel de temperatura • Indicador  : la máquina está lista preparar agua caliente	La máquina está lista para preparar bebidas	Preparar la máquina y proceder
 fija	La función ahorro energético está activa	Consulte el cap. "7. Menú configuraciones" se si desidera disattivare la funzione
 fija	El recipiente del café en granos (A2) está vacío	Llene el recipiente del café en granos
 parpadea	Si se desea proceder con la molienda, pero el recipiente del café en granos (A2) está vacío	Llene el recipiente del café en granos
 parpadea brevemente a intervalos regulares	El botón (B2) se ha girado hasta alcanzar el ajuste máximo a 	Cuando la cantidad molida no es suficiente para que la dosis sea correcta, seleccione el nuevo rango de molienda siguiendo las instrucciones del apdo. "6. Menù settings".
 fija	El agua del depósito (A14) es insuficiente o el depósito del agua no está bien metido	Llene el depósito o sáquelo y vuelva a meterlo correctamente





INDICADORES	SIGNIFICADO DE LOS INDICADORES	OPERACIÓN
 parpadea	Se desea proceder con la preparación de una bebida, pero el depósito de agua (A14) está vacío	Llene el depósito del agua
	La molienda es demasiado fina. Por lo tanto, el café sale muy lentamente o no sale del todo.	Saque la copa portafiltro (C1), repita las operaciones para hacer el café teniendo presente las indicaciones del apdo. "4.1 Fase 1 - Molienda (grinding)" y "4.2 Fase 2 - Pren-sado (tamping)"
	El filtro de café (C2) o (C3) está obstruido	Enjuague los filtros
	El depósito (A14) está mal colocado y las relativas válvulas no están abiertas	Presione ligeramente el depósito para abrir las válvulas
	Cal en el interior del circuito hidráulico	Efectúe la descalcificación como se explica en el cap. "11. Descalcificación"
 fija	El aparato está listo para l'uso	El aparato ha alcanzado la temperatura para suministrar vapor. Para proceder con el suministro gire el botón vapor (A4)
 parpadea	El aparato está encendido y la función ahorro energético está activa: el botón (A4) está en posición para suministrar vapor	El indicador luminoso parpadea para indicar que el aparato se está preparando para suministrar vapor: la salida empieza en cuanto el aparato alcanza la correspondiente temperatura
	El aparato está listo para el suministro de vapor	El aparato está en temperatura para la preparación de vapor cuando el indicador permanece fijo
	El aparato está suministrando vapor	
 fija	El recipiente del café en granos no está metido	Introduzca en el recipiente del café en granos (A2) en el molinillo de café. El recipiente está colocado correctamente cuando la flecha está alineada con el símbolo  y se oye un "clic".
		→

INDICADORES	SIGNIFICADO DE LOS INDICADORES	OPERACIÓN
 parpadea	El selector, en la base del recipiente del café en granos, no está en la posición correcta o está fuera de rango	Regrese el selector a una de las posiciones de molienda (entre 1 y 8), recordando: <ul style="list-style-type: none"> • Regular la molienda mientras el molinillo está en funcionamiento • Regular un nivel a la vez haga al menos 5 moliendas entre una regulación y la otra
		
 fija	El aparato requiere el prensado	Se acaba de realizar la molienda y el portafiltro está enganchado al molinillo
	El portafiltro se ha desenganchado del molinillo de café sin prensar	Desenganche el portafiltro y preñse el café como se indica en el apdo. "La "dosis perfecta"" "Cuando se usa café premolido:"
	El portafiltro ha sido desenganchado sin haber finalizado la molienda o bien el prensado ha sido realizado demasiado pronto	Repita la molienda
	La rampa del café del molinillo está obstruido	Límpiela como se indica en el apdo. "8.5 Limpieza de la "Smart tamping station"". Si el problema persiste, acceda a la rampa abriendo la respectiva puerta y libérela utilizando la escobilla
	Las muelas están bloqueadas por la presencia de un cuerpo extraño	Elimine el cuerpo extraño y limpie las muelas tal y como indicado en el apdo. "8.3 Limpieza de las muelas".
 fija (rojo)	Es necesario efectuar la descalcificación	Efectúe la descalcificación como se explica en el cap. "11. Descalcificación"
 parpadea (rojo) +  parpadea (naranja)	El aparato está efectuando la descalcificación	Termine la operación como se describe en el cap. "11. Descalcificación"
 parpadea (rojo) +  fija (blanco)	Es necesario proceder con el enjuague	
→		

INDICADORES	SIGNIFICADO DE LOS INDICADORES	OPERACIÓN
 lampeggi (rojo) +  lampeggia (blanco)	Es necesario proceder con el enjuague	
 fissa (naranja)	Es necesario proceder con la limpieza del surtidor de café	Vease “8.1 Limpieza del surtidor de café”
 lampeggiante (naranja)	El aparato está efectuando la limpieza del surtidor de café	
Todos los indicadores luminosos parpadean	Alarma general	Dirijase a un centro de asistencia

13. SOLUCIÓN DE PROBLEMAS

PROBLEMA	CAUSA	SOLUCIÓN
Hay agua en la bandeja de goteo (A10)	Esto es normal: debido a las operaciones de los circuitos internos de agua	Regularmente vacíe y limpie la bandeja de goteo
No es suministrado café espresso	No hay agua en el depósito (A14)	Llene el depósito
	La luz  (B6) está encendida para indicar que el circuito de café o de vapor está vacío	Pulse el botón correspondiente a la luz  para llenar el circuito
	El filtro de café (C2) o (C3) está bloqueado	Enjuague los filtros bajo abundante agua corriente
	El depósito (A14) ha sido insertado incorrectamente y las válvulas del fondo no están abiertas	Presione ligeramente el depósito para abrir las válvulas del fondo
	Calcificación en el circuito de agua	Descalcifique como se describe en la sección “11. Descalcificación”
	El café está molido muy fino	Saque la copa portafiltro (C1), repita las operaciones para hacer el café teniendo presente las indicaciones del apdo. “4.1 Fase 1 - Molienda (grinding)” y “4.2 Fase 2 - Prensado (tamping)”
El portafiltro no se engancha en el aparato	El café molido no ha sido prensado o hay excesiva cantidad	Repita la molienda con diferentes configuraciones. Reduzca la cantidad de la dosis: verifique que el filtro (C2) o (C3) (1 o 2 tazas) sea correcto respecto a la dosis a moler (botón 2x (B3) seleccionado o no)
El café espresso gotea por los bordes del portafiltro (C1) en lugar de por los orificios	El portafiltro está mal colocado	Enganche el portafiltro correctamente y gírelo hasta el tope con firmeza
	La junta del surtidor de café (A18) ha perdido elasticidad o está sucia	Sustituya la junta del surtidor de café en un Centro de Asistencia
	El filtro (C2) o (C3) está obstruido	Enjuague los filtros bajo el agua corriente
		→

PROBLEMA	CAUSA	SOLUCIÓN
La crema del café es clara (cae rápidamente por la boquilla)	Es necesario ver de nuevo las configuraciones del aparato	Saque la copa, repita las operaciones para hacer el café teniendo presentes las indicaciones del apdo. "4.1 Fase 1 - Molienda (grinding)" y "4.2 Fase 2 - Prensado (tamping)"
La crema del café es oscura (el café sale lentamente por la boquilla)	Es necesario ver de nuevo las configuraciones del aparato	Saque la copa portafiltro (C1), repita las operaciones para hacer el café teniendo presente las indicaciones del apdo. "4.1 Fase 1 - Molienda (grinding)" e "4.2 Fase 2 - Prensado (tamping)"
Al finalizar la descalcificación el aparato requiere un nuevo enjuague	Durante el enjuague el depósito no se ha llenado hasta el nivel MÁX	Repita el enjuague (véase apdo. "11. Descalcificación")
El aparato no muele el café	Dentro de la molienda hay un cuerpo extraño	Limpie las muelas como se indica en el apdo. "8.3 Limpieza de las muelas", asegurándose de haber quitado todos los granos del recipiente del café en granos (A2) antes de sacarlo. Antes de volver a colocar la muela, aspire cuidadosamente todo residuo de su lugar
	El recipiente del café en granos (A2) no está en la posición correcta	El recipiente está bien colocado cuando la flecha ▲ está alineada con el símbolo  y se escucha un "clac"
Si desea cambiar la calidad del café	Es necesario eliminar todos los granos presentes en la máquina	<ul style="list-style-type: none"> • Vacíe el recipiente de café en granos (A2) (moliendo en vacío o, en su caso, aspirando los granos residuales). • Enganche la copa portafiltro (C1) y haga moliendas "en vacío" para liberar el conducto del café: a continuación enganche el portafiltro a la salida del molinillo (A19)alineándolo el mensaje INSERT gire la copa hacia la derecha. La molienda inicia cuando la copa alcanza la posición CLOSE y se interrumpe automáticamente. Repita hasta que el filtro se quede vacío • Coloque en el recipiente (A2) el nuevo tipo de granos de café • Si con la molienda no se alcanza la "dosis perfecta", proceda como en el primer uso
		→

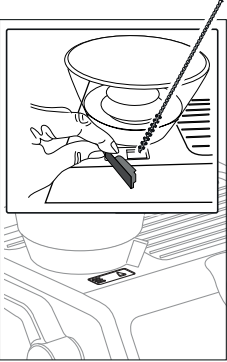
PROBLEMA	CAUSA	SOLUCIÓN
<p>Después de la molienda, el filtro de café (C2) o (C3) está vacío</p> <p>Una vez terminada la molienda, el polvo de café en el filtro es excesivo</p>	<p>La rampa del café del molinillo está obstruido</p>	<p>Límpiala como se indica en el apdo. "8.5 Limpieza de la "Smart tamping station"". Si el problema persiste, acceda a la rampa abriendo la respectiva puerta (A21) y libérela utilizando la escobilla</p> 
<p>Después de la molienda, el polvo de café en el filtro (C2) o (C3) no alcanza la "dosis perfecta"</p>	<p>La "Smart Tamping Station" precisa de limpieza</p> <p>Es necesario regular la cantidad de café molido</p> <p>Con el tiempo las muelas se desgastan</p>	<p>Límpiala como se indica en el apdo. "8.5 Limpieza de la "Smart tamping station"", luego repita la molienda</p> <p>Regule la cantidad con el botón correspondiente (B2) siguiendo las indicaciones en el apdo. "La "dosis perfecta"". Si el botón está ya en posición máx, proceda como se indica en la sección "7. Menú configuraciones" - "Regulación extra el grado de molienda"</p> <p>Proceda a la sustitución de las muelas tal y como indicado en el apdo."8.4 Sustitución de las muelas"</p>

Antes de utilizar o aparelho leia sempre o folheto dos avisos de segurança.

1. DESCRIÇÃO

1.1 Descrição do aparelho - A

- A1. Tampa depósito de café em grãos
- A2. Depósito café em grãos
- A3. Superfície de apoio das chávenas
- A4. Botão do vapor
- A5. Bico de saída de água quente
- A6. Tubo dispensador do vapor
- A7. Grelha de apoio das chávenas para expresso
- A8. Grelha de apoio das chávenas para copos ou malgas
- A9. Grelha do tabuleiro
- A10. Bandeja recolhe-gotas
- A11. Indicador de nível da água no recipiente de recolha de pingos
- A12. Tampa do reservatório de água
- A13. Asa extração depósito da água
- A14. Reservatório de água
- A15. Sede do filtro amaciador
- A16. Sede do conector do cabo de alimentação
- A17. Interruptor geral (ON/OFF)
- A18. Dispensador de café
- A19. Saída do moinho de café (Tamping station)
- A20. Alavanca de pressão
- A21. Portinhola para aceder à tremonha do moinho de café

1.2 Descrição do painel de comando - B

- B1. Tecla ON/Standby
- B2. Manípulo de regulação quantidade café moído
- B3. Tecla "X2": para a utilizar o filtro 2 de café
- B4. Botão "temperatura do café"
- B5. Tecla "OK": para dispensar a bebida/para confirmar
- B6. Tecla de "dispensação água quente"
- B7. Tecla "My": para personalizar o comprimento das bebidas
- B8. Botão de seleção de funções
 - Espresso
 - Americano
 - Coffee
 - Descalcificação
- B9. Indicador luminoso de "descalcificação"
- B10. Indicador luminoso "pronto vapor"
- B11. Indicador "ausência depósito de café em grão"
- B12. Indicador luminoso "poupança energética"
- B13. Indicador luminoso "Limpeza" (ver "8.1 Limpeza do dispensador de café")
- B14. Indicador luminoso "depósito de café em grãos vazio"
- B15. Indicador luminoso "falta água"
- B16. Indicador luminoso "pensagem"
- B17. Manómetro

1.3 Descrição dos acessórios - C

- C1. Compartimento porta-filtro
- C2. Filtro 1 chávena
- C3. Filtro 2 chávenas
- C4. Tira-teste "Total Hardness Test"
- C5. Descalcificante
- C6. Cabo de alimentação removível
- C7. Escova
- C8. Acessório limpeza dispensador de café
- C9. Softballs
- C10. Jarro de leite
- C11. Agulha de limpeza para lança vapor

1.4 Acessórios limpeza não incluídos, recomendados pelo fabricante

Para mais informações, consulte a Delonghi.com.



Pastilhas limpeza

(Ver "8.1 Limpeza do dispensador de café")

Detergente
EAN: 800439933307

2. PREPARAÇÃO DO APARELHO

Lavar com água morna e detergente da louça todos os acessórios e, em seguida, proceder conforme se segue:

1. Insira o depósito de café em grãos (A2) no moinho de café (fig. 1). O depósito está inserido corretamente quando a seta ▲ fica alinhada com o símbolo ☞ e sente-se um estalido (fig. 2).
2. Inserir o recipiente de recolha de pingos (A10) completo com grelha de apoio das chávenas (A8) e grelha do tabuleiro (A9) (fig. 3);
3. Extrair o reservatório de água (A14) (fig. 4) e enchê-lo com água fresca e limpa, tendo o cuidado para não ultrapassar a inscrição MAX (fig. 5).
4. Em seguida, reinserir o depósito.

Atenção: *Jamais ligar a máquina sem água no reservatório ou sem este último.*

Nota importante: *Aconselha-se personalizar o quanto antes o grau de dureza da água seguindo o procedimento descrito no capítulo "7. Menu de configurações".*

3. PRIMEIRA COLOCAÇÃO EM FUNCIONAMENTO DO APARELHO

1. Inserir o conector do cabo de alimentação (C6) no alojamento específico (A16) na traseira do aparelho (fig. 6); em seguida, introduzir a ficha do aparelho na tomada elétrica. Certificar-se de que o interruptor geral (A17), situado na parte traseira do aparelho, está premido na posição I (fig. 7);
2. Coloque sob o dispensador de água quente (em correspondência ao dispensador de café (A18)) um recipiente com capacidade mínima de 100 ml (fig. 8);

3. Premir a tecla (B6) correspondente ao indicador luminoso  (fig. 9): a dispensação inicia e interrompe-se automaticamente. Esvaziar o depósito.

Antes de começar a utilizar a máquina, é necessário enxaguar os circuitos internos da mesma. Proceda da seguinte maneira:

4. Encaixar o compartimento porta-filtro (C1) completo com filtro na máquina: para um encaixe correto, alinhar a pega do compartimento porta-filtro com "INSERT" (fig. 10) e rodar o manípulo para a direita, até o alinhar com a posição "CLOSE";
5. Coloque um recipiente sob o copo porta-filtro e o tubo dispensador do vapor (A6);
6. Prima o botão OK (B5) (fig. 11): a dispensação começa;
7. Uma vez terminada a dispensação, rode o manípulo do vapor (A4) (fig. 12) e dispense vapor durante alguns segundos, de forma a enxaguar o circuito de vapor: para uma dispensação ótima do vapor, aconselha-se a repetir esta operação 3 ou 4 vezes. Isto permite eliminar a água no tubo antes de dispensar o vapor.

O aparelho fica assim pronto para o uso.

Nota Importante: o enxaguamento dos circuitos internos é recomendado também em caso de inutilização prolongada do aparelho.

Na primeira utilização, é necessário fazer 4-5 cafés antes de a máquina começar a dar um resultado satisfatório: dedique particular atenção à dose de café moído no filtro ((C2) ou (C3)) (ver instruções na secção "4.1 Fase 1 - Moagem (grinding)").

Proceder conforme o indicado no capítulo "A "dose perfeita"".

4. PREPARAR O CAFÉ

4.1 Fase 1 - Moagem (grinding)

1. Verta os grãos para o depósito (A2) (fig. 13). É aconselhável verter apenas os grãos necessários para a preparação: desta forma, será sempre usado café fresco;
2. Selecione o grau de moagem (fig. 14). A configuração de fábrica é 5 (moagem média). Se o resultado não for satisfatório, regule o nível com base no sabor pessoal e no tipo de café (a regulação deve ser efetuada durante o funcionamento do moinho de café).

Nota Importante: O grau de moagem entre 3 e 6 é aconselhado para a maior parte dos cafés. O resultado da moagem com a seleção em 1 ou 2, é muito fina, devendo apenas ser utilizada com café muito específico (tostagem leve).

3. Insira um dos filtros de café (C2) ou (C3) no porta-filtro (C1) (fig. 15). Caso seja usado o filtro para 2 chavenas, prima o botão X2 (B3): com esta seleção, duplica também a quantidade de expresso dispensada.
4. Regule o manípulo da quantidade (B2) partindo da posição mínima (fig. 16).

Para mais indicações, consulte a secção "Regular a quantidade de café moído no filtro".

5. Engate o porta-filtro à saída do moinho de café (A19) alinhando-o com a mensagem INSERT: em seguida, rode para a direita o copo. A moagem tem início quando o compartimento atinge a posição CLOSE e é automaticamente interrompida.

Regular a quantidade de café moído no filtro

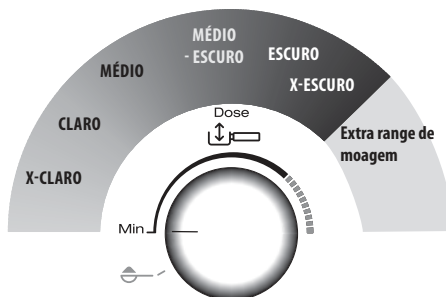

Cada variedade de grão dá um resultado diferente durante a moagem e para tal, no início da regulação da dose, é necessário um extremo cuidado.

Esta ilustração dá indicações sobre como regular a dose, com base na cor de tostagem: devem ser consideradas como um ponto de partida, mas podem variar em função da composição do café em grão.

1. Configure a dose a partir da posição mínima.
2. Verificando a cor de tostagem do seu café, rode lentamente o manípulo.

4.2 Fase 2 - Pressagem (tamping)

1. Após a moagem, abaixe a alavanca de pressagem (A20) até ao fim de curso (não remova o porta-filtro) (fig. 17). Para um resultado perfeito, repita 2 vezes.
2. Mantenha a alavanca abaixada até ao fim de curso durante a remoção do porta-filtro (fig. 18). Em seguida, recolque a alavanca na posição inicial.
3. Depois de se certificar de que a dose do café está correta (ver "A "dose perfeita""), engate o porta-filtro no dispensador de café (A18) (fig. 19).

Nota Importante: Se depois da pressagem permanecerem resíduos de café ao longo das bordas do filtro, isto não prejudica de forma alguma a qualidade da extração e, por conseguinte, o resultado final.

A "dose perfeita"

- Os filtros de café possuem uma referência interna para identificar a dose perfeita.

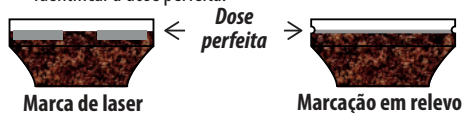





- Filtros com marcação de laser: a dose perfeita corresponde à linha superior da marcação;
 - Filtro com marcação em relevo: a dose perfeita corresponde à linha em relevo;
- Certifique-se de que o café esteja no nível após a prensagem. Poderá ser necessário regular mais vezes o manípulo (B2) antes de se chegar à dose perfeita.
 - Se o café for sobre ou subextraído e a dose estiver dentro da dose perfeita, regule o grau de moagem para mais fino ou mais grosso (ver "4.1 Fase 1 - Moagem (grinding)"). Se o café estiver sobreextraído (dispensação demasiado lenta), a moagem deverá ser mais grossa. Se o café estiver subextraído (dispensação demasiado rápida), a moagem deverá ser mais fina.
 - **O barista aconselha:** Extraia o porta-filtro enquanto a alavanca da prensa (A20) é abaixada para obter um acabamento perfeito da dose de café.
 - **Se se utilizar café pré-moído:**
 - verta o café pré-moído para o filtro;
 - rode o manípulo para ;
 - engate o porta-filtro à saída do moinho de café;
 - abaixe a alavanca de prensagem.

4.3 Fase 3 - Dispensação (brewing)

1. Selecione a temperatura (fig. 20) (ver "A temperatura para preparar o café").
2. Selecione a bebida desejada (fig. 21).
3. Prima OK (B5) para iniciar a preparação (fig. 11) (pré-infusão e infusão). A preparação do café interrompe-se automaticamente.

A temperatura para preparar o café

A temperatura da água é controlada durante todo o processo de preparação, para garantir a estabilidade na fase de extração. A Specialista Prestigio oferece 3 temperaturas de infusão* que correspondem a um intervalo entre 92°C e 96°C. Consoante a variedade e a tostagem do café em grão, aconselha-se uma temperatura diferente: o café em grão Robusta exige uma temperatura baixa, o café em grão Arabica uma temperatura alta. O mesmo é válido para o café em grão com tostagem escura ou para o café em grão acabado de tostar.

Nível de temperatura	Indicador luminoso correspondente	Nível de tostagem
MÍN	 	Escuro
MÉD	 	Médio-escuro

MÁX.	 	Claro - médio
-------------	---	----------------------

- * Esta temperatura diz respeito à água no thermoblock. É por isso diferente da temperatura da bebida na chávena ou da temperatura medida quando a bebida sai pelos bicos de café do porta-filtro.

5. PREPARAÇÃO DE BEBIDAS À BASE DE LEITE

5.1 Espume o leite

1. Verta para o jarro (C10) a quantidade de leite que pretende aquecer/espumar, tendo em conta que o volume do leite irá aumentar para o dobro ou o triplo (fig. 22). Para obter uma espuma mais densa e homogénea, é aconselhável utilizar leite de vaca gordo à temperatura de frigorífico (cerca de 5°C).

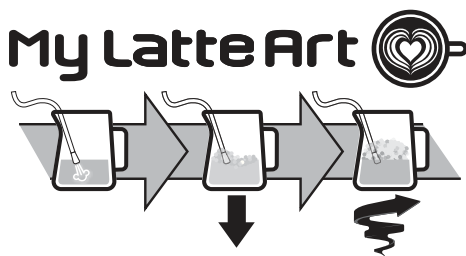

2. Para espumar o leite, apoie o tubo dispensador do vapor (A6) na superfície do leite: ao proceder assim, o ar mistura o leite com o vapor.
3. Mantenha o dispensador do vapor na superfície, prestando atenção para não captar demasiado ar, criando bolhas demasiado grossas.
4. Submerja o dispensador de vapor sob a superfície do leite: desta forma, cria-se um vórtice. Uma vez atingida a temperatura desejada, volte a fechar o manípulo do vapor e aguarde que a dispensação de vapor se interrompa completamente, antes de remover o jarro de leite.

O barista aconselha:

- **O leite fresco é melhor.** Utilizar sempre leite fresco à temperatura do frigorífico.
- Para um resultado melhor, é aconselhável voltar a colocar sempre o jarro do leite no frigorífico.
- O leite gordo assegura resultados ótimos. O resultado e as texturas da espuma variam consoante seja leite de vaca ou bebidas vegetais.
- Depois de ter espumado o leite, elimine as bolhas rodando ligeiramente o jarro do leite.

Limpeza do dispensador de vapor:

1. Após cada utilização, remova com um pano os resíduos de leite do dispensador de vapor (fig. 23). Para uma limpeza profunda, é aconselhável utilizar o Eco MultiClean: assegure a higiene removendo as proteínas e gorduras do leite, e pode ser usado para limpar a máquina inteira.
2. Dispense vapor durante alguns segundos para limpar bem o dispensador (fig. 12).
3. Aguarde que o dispensador arrefeça: para manter a eficiência do dispensador ao longo do tempo, utilize a agulha de limpeza (C11) para manter os 3 orifícios desobstruídos (fig. 24).

6. PERSONALIZAR O COMPRIMENTO DAS BEBIDAS À BASE DE CAFÉ COM A TECLA (my) (B7)





1. Preparar a máquina para dispensar 1 ou 2 chávemas da bebida à base de café que deseja dispensar, até engatar o porta-filtro (C1) completo com filtro (C2) ou (C3) e café moído.
2. Rode o manípulo (B8) para selecionar a bebida a programar.
3. Prima o botão (my): o indicador luminoso correspondente ao botão (my) pisca.
4. Prima o botão OK para iniciar a dispensação. Os indicadores luminosos correspondentes aos botões OK e (my) piscam.
5. Uma vez atingida a quantidade desejada, prima OK. Se a bebida previr a dispensação de outro ingrediente, começa a dispensação deste último: uma vez atingida a quantidade desejada, prima OK.
6. Prima o botão (my) para guardar. O aparelho está pronto para uma nova utilização e o indicador luminoso (my) permanece aceso.

Caso não deseje guardar a programação, prima qualquer outro botão.







Nota Importante:



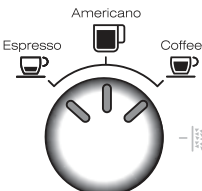



- É possível programar as bebidas com café, mas não a dispensação de vapor e água quente.
- A programação modifica as quantidades das bebidas, mas não do café moído.
- As bebidas "X2" podem ser programadas separadamente.
- **Para regressar às configurações de fábrica, mantenha premido o botão (my) até ao seu desligamento. A bebida selecionada regressa à quantidade de fábrica.**

Receita de café	Quantidade de fábrica	Quantidade programável
 Espresso	35 ml	de 25 a 90 ml

Receita de café	Quantidade de fábrica	Quantidade programável
 Espresso X2	70 ml	de 50 a 180 ml
 Coffee	80 ml	de 50 a 120 ml
 Coffee X2	160 ml	de 120 a 240 ml
 Americano	120 ml	<ul style="list-style-type: none"> • espresso: de 25 a 60 ml • água: de 25 a 120 ml
 Americano X2	240 ml	<ul style="list-style-type: none"> • espresso: de 50 a 120 ml • água: de 50 a 240 ml

7. MENU DE CONFIGURAÇÕES

1. Entre no menu:		
Prima em simultâneo durante 5 segundos	x2	(my)
2. Configurações com seleção a partir do manípulo (B8)		
		
Configuração correspondente	Rode para	Regulações
Regulação extra da moagem	 Espresso	x2 → Range 1
		 → Range 2
Dureza da água	 Americano	x2 → macia
		 → média
		 → dura/muito dura
		→

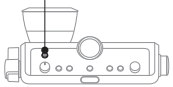
Desligar automático	 Coffee	×2 → 9 minutos
		☰ → 1,5 horas
		OK → 3 horas
3. Configuração com seleção a partir do botão:		
Poupança de energia	 → Ativo	
	 →  Desligado	
Valores fábrica	Mantenha premido durante pelo menos 5 segundos o botão  , até o indicador luminoso permanecer continuamente aceso	
4. Guarde as novas configurações premindo ON/Standby (B1)		
 		











8. LIMPEZA DO APARELHO

Atenção!

- Para a limpeza da máquina, não utilize solventes, detergentes abrasivos ou álcool.
- Não utilize objetos metálicos para retirar incrustações ou depósitos de café, porque podem riscar as superfícies metálicas ou plásticas.
- Para períodos de inutilização superiores à semana é aconselhado, antes de utilizar a máquina, proceder a um enxaguamento.



Perigo!

- Durante a limpeza, jamais mergulhar a máquina na água: é um aparelho elétrico.
- Antes de qualquer operação de limpeza das partes externas do aparelho, desligar a máquina, tirar o plugue da tomada e esperar até que a máquina esfrie.

					
	×	✓	✓	×	×
	✓	×	×	✓	✓
	×	×	×	✓	✓
	×	×	×	✓	✓
	×	×	✓	✓	×
	×	×	×	✓	✓

8.1 Limpeza do dispensador de café

Quando o indicador luminoso  se acender (laranja) (B13), é necessário proceder à limpeza do circuito do café. Para efetuar o ciclo de limpeza, adquira as pastilhas para a limpeza de máquinas de café. Para mais informações, visite www.Delonghi.com.

1. Insira no filtro 1 chávena (C2) no porta-filtro (C1) (fig. 25).
2. Insira no filtro o acessório de limpeza (C8) (fig. 25) e prima-o a fundo.
3. Coloque a pastilha para a limpeza no acessório (fig. 26).
4. Engate o porta-filtro no dispensador de café (A18).
5. Encha o reservatório de água (A14). Certifique-se de que o tabuleiro de recolha dos pingos (A10) está vazio.
6. Mantenha premido o botão  (B6), até que se acenda o indicador luminoso  (B13). Após alguns minutos, a limpeza interrompe-se automaticamente.
7. Remova o porta-filtro e o acessório de limpeza.
8. Lave o porta-filtro e o filtro sob água corrente.
9. Reinsira o porta-filtro e proceda a um enxaguamento, premindo o botão  : aconselha-se a colocar um recipiente sob o porta-filtro.
10. Remova e esvazie o tabuleiro de recolha pingos.

Nota Importante:

Este ciclo de limpeza pode ser iniciado a qualquer momento premindo o botão  durante alguns segundos. Para cancelar a operação, prima o botão durante 10 segundos.

8.2 Limpe o alojamento do recipiente de depósito em grãos

1. Certifique-se de que o recipiente de depósito em grãos (A2) esteja vazio. Eventualmente, proceda a efetuar algumas moagens no vazio para o esvaziar.
2. Desengate o recipiente rodando-o para a esquerda e extraia-o da máquina (fig. 27)
3. Aspirar os resíduos de café (fig. 28).
4. Limpar com um pano macio a sede do depósito do café em grão e secar (fig. 29);
5. Reposicione o depósito inserindo-o no moinho de café. O depósito está inserido corretamente quando a seta ▲ fica alinhada com o símbolo ☞ e sente-se um estalido (fig.30).

8.3 Limpeza dos moinhos

Quando se limpa o depósito para café em grão (A2), limpe a sede do depósito e o moinho superior com um pano húmido. Dirija-se a um centro de assistência para remover e substituir os moinhos. É possível remover o moinho sempre que o moinho de café estiver bloqueado por um corpo estranho. Se tal ocorrer, remova o depósito para café em grão e proceda como explicado a seguir:

1. Engate o copo do porta-filtro (C1) e faça uma moagem “no vazio” para escoar a conduta do café.
2. Desligar o aparelho.
3. Rodar para a esquerda o regulador de moagem até ao batede, na posição “REMOVE” (fig. 31).
4. Extraia a parte superior do moinho, pegando no mesmo pela correspondente asa (fig.32).
5. Limpar o moinho com um pincel (fig. 33) e aspirar os resíduos de café com um aspirador do pó (fig. 28).

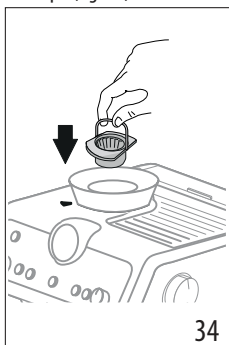
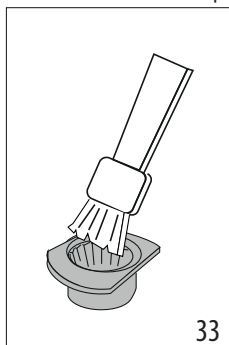

6. Inserir o moinho no seu alojamento (fig. 34);
7. Rodar o regulador selecionando o grau de moagem desejado (fig. 14);

Verificar se o moinho se encontra bem inserido, puxando-o pela asa: o moinho encontra-se corretamente inserido caso não se mova.

8.4 Substituição dos moinhos

Quando a quantidade de café moído diminuir ainda mais, dirija-se a um centro de assistência para substituir os moinhos: em seguida, regule de novo o moinho de café entrando no menu de configurações (“7. Menu de configurações”) e selecionando o primeiro range de regulação adicional da moagem. Em seguida, rode o manipulador de regulação da quantidade (B2) para a posição MÍN e regule a dose como para a primeira utilização (ver “A “dose perfeita””).

8.5 Limpeza da “Smart tamping station”

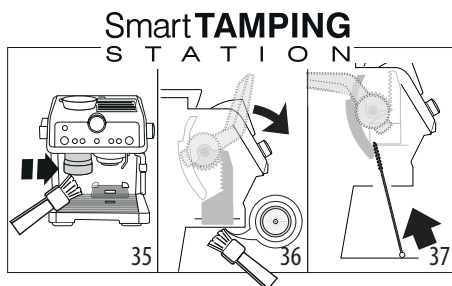

1. Limpar a zona de engate com um pincel (fig. 35).
2. Puxe a alavanca (A20) até ao fim de curso e limpe com um pincel a prensa (fig. 36) e, em seguida, solte a alavanca.
3. Utilizando a escova (C7), limpar a tremonha de café (fig. 37).



9. DUREZA DA ÁGUA

O indicador luminoso ☞ (B9) de descalcificação acende-se depois de um período de funcionamento pré-determinado, que depende do grau de dureza da água. É possível programar a máquina com base na dureza real da água fornecida pela rede nas diversas regiões, tornando, assim, menos frequente a operação de descalcificação.

1. Retirar da embalagem a tira reativa a fornecida “TOTAL HARDNESS TEST” (C4).
2. Mergulhe completamente a tira num copo com água durante cerca de um segundo.
3. Extraia a tira da água e sacuda-a ligeiramente. Configure o aparelho, conforme indicado no capítulo “7. Menu de configurações”.

Resultado do teste de dureza da água	Tecla	Nível
	×2	1 água doce
	☞	2 água média

Resultado do teste de dureza da água	Tecla	Nível
	OK	3 água dura ou muito dura

- Configure o aparelho, conforme indicado no capítulo "7. Menu de configurações".

10. COMO UTILIZAR SOFTBALLS

Softballs (C9) consiste num sistema inovador que prolonga a vida útil da máquina sem alterar as qualidades da água, garantindo a extração de um café cremoso e aromático. Para otimizar a eficácia, deixe Softballs na água durante a noite anterior à utilização.

- Extraia o pacote de Softballs da embalagem (fig. 38).

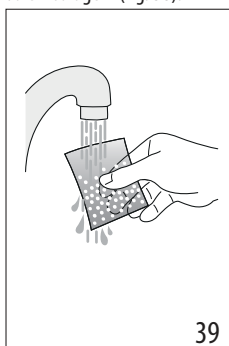
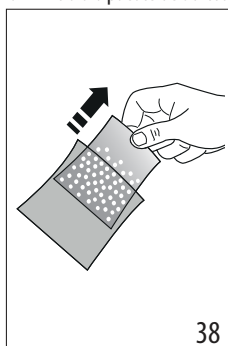

- Enxague com água corrente o pacote de Softballs (fig. 39).
- Submerja a saqueta no reservatório de água (A14) (fig. 40).

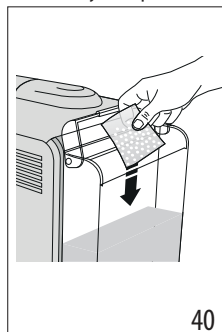

- Substitua a saqueta de Softballs a cada 3 meses (fig. 41).

11. DESCALCIFICAÇÃO

Atenção!

- Antes de utilizar, leia as instruções e a etiqueta do descalcificante (C5), indicadas na embalagem do próprio descalcificante.
- Recomenda-se utilizar exclusivamente o descalcificante De'Longhi. O uso de descalcificantes inadequados, assim como a descalcificação não realizada regularmente, pode comportar o surgimento de defeitos não cobertos pela garantia do fabricante.
- O descalcificante pode danificar as superfícies delicadas. Se o produto for acidentalmente derramado, seque-o de imediato.

Para efetuar a descalcificação

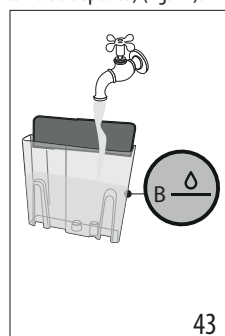
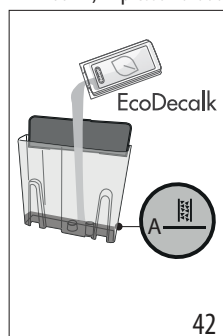

Descalcificador	Descalcificador De'Longhi
Depósito	Capacidade de 2 litros
Tempo	~40min

- (SE PRESENTES, RETIRE O FILTRO AMACIADOR E SOFTBALLS). Verta o descalcificante no depósito de água (A14) até ao nível A (correspondente a uma embalagem de 100 ml) impresso no lado interno do depósito (fig. 42).

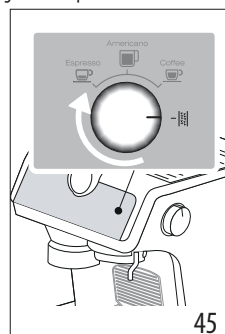
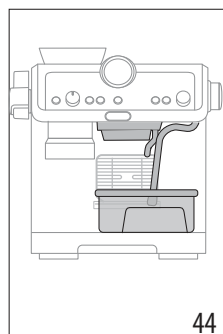

- Adicione água até atingir o nível B (fig. 43). Em seguida, reintroduza o reservatório de água na máquina.



3. Certifique-se de que o porta-filtro (C1) não esteja engatado e coloque um recipiente sob os dispensadores de café, de água quente, e sob o dispensador de vapor (A6) (fig. 44).
 4. Rode o manípulo (B8) para  (fig. 45): o indicador luminoso OK acende-se a laranja; o indicador luminoso  pisca.
 5. Prima o botão OK: o indicador luminoso OK pisca.
 6. O programa de descalcificação inicia e o líquido descalcificante sai pelos dispensadores. O programa de descalcificação executa automaticamente toda uma série de enxaguamentos a intervalos regulares para remover os resíduos de calcário do interior da máquina de café até esvaziar o reservatório.
- A dispensação é interrompida e o indicador luminoso OK passa a branco. É então necessário proceder a um ciclo de enxaguamento:
7. Esvaziar o depósito usado para a recolha do líquido descalcificante e voltar a colocá-lo sob os dispensadores.
 8. Extrair o reservatório de água, esvaziá-lo de eventuais resíduos de solução descalcificador, enxaguá-lo com água corrente e enchê-lo com água fresca até ao nível MAX (fig. 46). Reinsere-lo depois o depósito no seu alojamento.
 9. Prima o botão OK: o enxaguamento arranca.
 10. Uma vez concluído o enxaguamento, a dispensação interrompe-se e o aparelho está pronto para ser utilizado.
 11. Esvaziar os depósitos de recolha da água de enxaguamento.
 12. Extrair e esvaziar o compartimento de recolha de pingos e, em seguida, voltar a inseri-lo.
 13. Extrair e encher o reservatório de água com água fresca e, em seguida, voltar a inseri-lo.



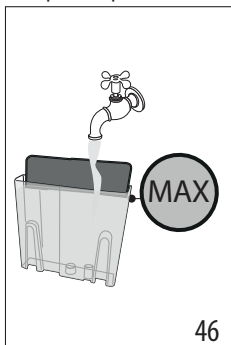

O aparelho assim está pronta ao uso.

Nota Importante:









- O ciclo de descalcificação pode ser iniciado a qualquer momento (mesmo se o respetivo indicador luminoso ainda não se tiver acendido).
- Caso a descalcificação tenha sido acionada por engano, prima o botão OK durante 10 segundos; o enxaguamento não pode ser interrompido.

















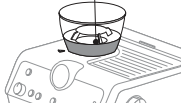

12. SIGNIFICADO DOS INDICADORES LUMINOSOS

INDICADORES LUMINOSOS	SIGNIFICADO LUMINOSOS	INDICADORES	OPERAÇÃO
Todos os indicadores luminosos piscam curtamente	Ligação do aparelho		Auto-diagnóstico
 fixo	É a primeira ativação da máquina e é necessário proceder ao enchimento do circuito da água		Proceda conforme o indicado no cap. "3. Primeira colocação em funcionamento do aparelho"
 fixo (branco)	A máquina está pronta para a extração		Prepare a máquina e proceda à preparação da bebida
<ul style="list-style-type: none"> • Indicador luminoso : indica a temperatura do café selecionada • Indicador luminoso : indica que a máquina está pronta para dispensar água quente 			





INDICADORES LUMINOSOS	SIGNIFICADO LUMINOSOS	INDICADORES	OPERAÇÃO
 fixo	A função de poupança energética encontra-se ativa		Consulte o cap. “7. Menu de configurações” caso deseje reativar a função
 fixo	O depósito de café em grãos (A2) está vazio		Encher o depósito de café em grãos
 intermitente	Caso deseje proceder à moagem, mas o recipiente de café em grãos (A2) estiver vazio		Encher o depósito de café em grãos
 pisca curtamente a intervalos regulares	O manípulo (B2) está rodado para a posição de regulação máxima 		Quando após a moagem o café no filtro for insuficiente, selecione um novo range de moagem conforme indicado no capítulo “7. Menu de configurações”.
 fixa	A água no depósito (A14) não é suficiente ou o reservatório de água não se encontra bem inserido		Encher o depósito ou extrair e voltar a inserir corretamente o depósito
 intermitente	Caso deseje proceder à preparação de uma bebida, mas o reservatório de água (A14) esteja vazio		Encher o reservatório de água
	A moagem é muito fina e, portanto, o café sai muito lentamente ou não sai de todo.		Extrair o compartimento (C1), repetir as operações para fazer o café, tendo em mente as indicações da sec. “4.1 Fase 1 - Moagem (grinding)” e “4.2 Fase 2 - Prensagem (tamping)”
	O filtro de café (C2) ou (C3) está obturado		Enxague os filtros sob água corrente
	O depósito (A14) está mal inserido e as respetivas válvulas não estão abertas		Prima levemente o reservatório de forma a abrir as válvulas
	Há calcário no circuito hidráulico		Efetuar a descalcificação conforme indicado no cap. “11. Descalcificação”
 fixo	O aparelho está pronto para a dispensação de vapor		O aparelho atingiu a temperatura para dispensar vapor. Para proceder à dispensação, rode o manípulo do vapor (A4)
			→

INDICADORES LUMINOSOS	SIGNIFICADO INDICADORES LUMINOSOS	OPERAÇÃO
 intermitente	O aparelho está ligado e a função de poupança energética encontra-se ativa: o botão do vapor (A4) está na posição de dispensação de vapor	O indicador luminoso pisca a indicar que o aparelho se está a preparar para dispensar vapor: o dispensador inicia mal o aparelho esteja à temperatura
	O aparelho está pronto para a dispensação de vapor	O aparelho está à temperatura para a preparação de vapor quando o indicador luminoso permanece fixo
	O aparelho está a dispensar vapor	
 fixo	O depósito de borras de café não está inserido	Insira corretamente o depósito para café em grão (A2) ou certifique-se de que esteja corretamente inserido. O depósito está inserido corretamente quando a seta ▲ fica alinhada com o símbolo  e sente-se um estalido
 intermitente	A regulação do seletor do grau de moagem não está correta ou está para lá da regulação máxima possível	Volte a colocar o seletor numa das posições de moagem (entre 1 e 8), lembrando-se de: <ul style="list-style-type: none"> • Regular a moagem enquanto o moinho de café está em funcionamento • Regule em um nível de cada vez e faça pelo menos 5 moagens entre uma regulação e a outra
	<div style="display: flex; align-items: center; justify-content: space-between;"> <div style="text-align: center;"> <p>FORA do intervalo correto</p>  </div> <div style="text-align: center;"> <p>Intervalo correto</p>  </div> </div> <div style="text-align: center; margin-top: 10px;">  </div>	
→		

INDICADORES LUMINOSOS	SIGNIFICADO INDICADORES LUMINOSOS	OPERAÇÃO
 fixa	O aparelho requer a prensagem	Acabou de ser realizada a moagem e o porta-filtro foi engatado no moinhos de café
	O porta-filtro foi desengatado do moinho do café sem prensar	Desengate o porta-filtro e proceda prensando o café conforme o descrito na sec. "A "dose perfeita"" "Se se utilizar café pré-moído:"
	O porta-filtro foi desengatado sem concluir a moagem ou a prensagem foi efetuada demasiado cedo	Repetir a moagem
	A tremonha do café do moinho de café está entupida	Proceder à limpeza conforme indicado na sec. "8.5 Limpeza da "Smart tamping station"". Se o problema persistir, aceda à tremonha abrindo a portinhola correspondente e solte-a utilizando a escovinha
	Os moinhos estão encravados devido a um corpo estranho	Remova o corpo estranho e limpe os moinhos conforme indicado no par. "8.3 Limpeza dos moinhos".
 fixo (vermelho)	É necessário proceder à descalcificação	Efetuar a descalcificação conforme o ilustrado na sec. "11. Descalcificação"
 intermitência (vermelha) +  intermitência (laranja)	O aparelho encontra-se a realizar a descalcificação	Proceda realizando a operação conforme o descrito no cap. "11. Descalcificação"
 intermitência (vermelha) +  fixa (branca)	É necessário proceder ao enxaguamento	
 intermitências (vermelha) +  intermitência (branca)	O aparelho está a efetuar o enxaguamento do ciclo de descalcificação	
 fixa (laranja)	É necessário proceder à limpeza do dispensador de café	Ver par. "8.1 Limpeza do dispensador de café"
 intermitente (laranja)	O aparelho está a efetuar a limpeza do dispensador de café	
Todos os indicadores luminosos piscam	Alarme genérico	Dirija-se a um centro de assistência

13. SE ALGO NÃO FUNCIONAR

PROBLEMA	CAUSA	SOLUÇÃO
Está presente água no tabuleiro de recolha dos pingos (A10)	Faz parte do funcionamento normal dos circuitos internos da máquina	Esvazie e limpe regularmente o tabuleiro de recolha de pingos
Não sai mais café expresso	Falta de água no reservatório (A14)	Encher o reservatório
	O indicador luminoso  (B6) está aceso para indicar que o circuito de café ou circuito de vapor está vazio	Prima o botão correspondente ao indicador luminoso  para encher o circuito
	O filtro (C2) ou (C3) está obturado	Enxague os filtros sob água corrente
	O depósito (A14) está mal inserido e ad válvula no fundo não estão abertas	Pressionar levemente o depósito de modo a abrir as válvulas em seu fundo
	Há calcário no circuito hidráulico	Efetuar a descalcificação conforme indicado no cap. "11. Descalcificação"
	Moagem demasiado fina	Extrair o compartimento (C1), repetir as operações para fazer o café, tendo em mente as indicações da sec. "4.1 Fase 1 - Moagem (grinding)" e "4.2 Fase 2 - Prensagem (tamping)"
O porta-filtro não se encaixa ao aparelho	O café moído não foi prensado ou está em quantidade excessiva	Repita a moagem com configurações diferentes. Reduza a quantidade da dose: certifique-se de que o filtro (C2) ou (C3) (1 ou 2 chávenas) está correto em relação à dose a moer (botão 2x (B3) selecionado ou não)
O café expresso pinga das bordas do porta-filtro (C1) e não através dos furos	O porta-filtro está mal inserido	Encaixar o porta-filtro corretamente e girá-lo até o fim com força
	O vedante do dispensador do café (A18) perdeu elasticidade ou está suja	Substitua o vedante do dispensador de café junto de um Centro de Assistência
	O filtro (C2) ou (C3) está obturado	Enxague os filtros sob água corrente
O creme do café é claro (desce rapidamente do bico)	É necessário rever as configurações do aparelho	Extrair o compartimento, repetir as operações para fazer o café, tendo em mente as indicações da sec. "4.1 Fase 1 - Moagem (grinding)" e "4.2 Fase 2 - Prensagem (tamping)"
O creme do café é escuro (o café desce lentamente do bico)	É necessário rever as configurações do aparelho	Extrair o compartimento (C1), repetir as operações para fazer o café, tendo em mente as indicações da sec. "4.1 Fase 1 - Moagem (grinding)" e "4.2 Fase 2 - Prensagem (tamping)"
No término da descalcificação, o aparelho precisa de outro enxaguamento	Durante o ciclo de enxaguamento, o depósito não foi enchido até ao nível MAX	Repita o enxaguamento (ver cap. "11. Descalcificação")
		→

PROBLEMA	CAUSA	SOLUÇÃO
O aparelho não mói o café	No interior do moinho de café está presente um corpo estranho	Proceder à limpeza dos moinhos conforme indicado na sec. “8.3 Limpeza dos moinhos”, certificando-se de remover todo o café em grãos do depósito do café em grãos (A2) antes de o extrair. Antes de reinserir o moinho, aspire cuidadosamente todos os resíduos da sua sede
	O depósito de café em grão (A2) não está na posição correta	O depósito está inserido corretamente quando a seta ▲ fica alinhada com o símbolo ☞ e sente-se um estalido
Se se desejar alterar a qualidade do café	É necessário eliminar todo o café em grãos presente na máquina	<ul style="list-style-type: none"> • Esvazie o depósito café em grãos (A2) (fazendo moagens em vazio ou eventualmente aspirando o café em grãos residual). • Engate o compartimento porta-filtro (C1) e efetue moagens “vazias” para libertar o tubo de passagem do café: engate em seguida o porta-filtro à saída do moinho do café (A19) alinhando-o com a inscrição INSERT e rode para a direita o copo. A moagem tem início quando o compartimento atinge a posição CLOSE e é automaticamente interrompida. Repetir até que o filtro permaneça vazio • Insira no depósito (A2) a nova variedade de café em grão • Se a moagem não atingir a “dose perfeita”, proceda conforme na primeira utilização
		→

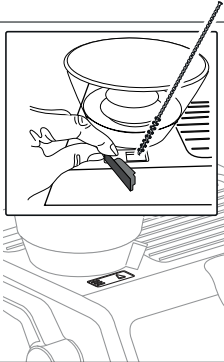
PROBLEMA	CAUSA	SOLUÇÃO
<p>Após a moagem, o filtro de café (C2) ou (C3) está vazio</p> <p>Após a moagem, o pó do café no filtro é demasiado abundante</p>	<p>A tremonha do café do moinho de café está entupida</p>	<p>Proceder à limpeza conforme indicado na sec. "8.5 Limpeza da "Smart tamping station"". Se o problema persistir, aceda à tremonha abrindo a portinhola correspondente (A21) e solte-a utilizando a escovinha</p> 
<p>Após a moagem, o café em pó no filtro (C2) ou (C3) não atinge a "dose perfeita"</p>	<p>A "Smart Tamping Station" precisa de ser limpa</p> <p>É necessário regular a quantidade de café moído</p> <p>Com o tempo os moinhos desgastam-se</p>	<p>Proceder à limpeza conforme indicado na sec. "8.5 Limpeza da "Smart tamping station"", em seguida, repita a moagem</p> <p>Regular a quantidade com o manípulo correspondente, (B2) seguindo as indicações na secç. "A "dose perfeita"". Se o manípulo já estiver na posição máx., proceda conforme indicado na secção "7. Menu de configurações" - "Regulação extra da moagem"</p> <p>Proceder à substituição dos moinhos conforme indicado na sec. "8.4 Substituição dos moinhos"</p>

Πριν χρησιμοποιήσετε τη συσκευή, διαβάστε πάντα το φύλλο των προειδοποιήσεων ασφαλείας.

1. ΠΕΡΙΓΡΑΦΗ

1.1 Περιγραφή της συσκευής - A

- A1. Καπάκι δοχείου κόκκους
- A2. Δοχείο για κόκκους
- A3. Δίσκος φλιτζανιών
- A4. Διακόπτης ατμού
- A5. Στόμιο παροχής ζεστού νερού
- A6. Σωλήνας παροχής ατμού
- A7. Σχάρα φλιτζανιών για espresso
- A8. Σχάρα φλιτζανιών για ποτήρια ή κούπες
- A9. Σχάρα δίσκου
- A10. Δίσκος συλλογής σταγόνων
- A11. Δείκτης στάθμης νερού στο δίσκο συλλογής σταγόνων
- A12. Καπάκι δοχείου νερού
- A13. Λαβή αφαίρεσης δοχείου νερού
- A14. Δοχείο νερού
- A15. Θήκη φίλτρου αποσκλήρυνσης νερού
- A16. Σημείο σύνδεσης καλωδίου τροφοδοσίας
- A17. Γενικός διακόπτης (ON/OFF)
- A18. Ακροφύσιο καφέ
- A19. Εξοδος μύλου καφέ (Tamping station)
- A20. Μοχλός πατητηριού
- A21. Πορτάκι για πρόσβαση στο χωνί του μύλου καφέ

1.2 Περιγραφή πίνακα ελέγχου - B

- B1. Κουμπί ON/Standby
- B2. Κουμπί ρύθμισης ποσότητας αλεσμένου καφέ
- B3. Κουμπί «Χ2»: για χρήση του φίλτρου 2 καφέδων
- B4. Κουμπί «θερμοκρασία καφέ»
- B5. Κουμπί «OK»: για την παροχή ροφήματος/για επιβεβαίωση
- B6. Κουμπί «παροχή ζεστού νερού»
- B7. Κουμπί «My»: για εξατομίκευση της γεύσης των ροφημάτων
- B8. Διακόπτης επιλογής λειτουργιών
 - Espresso
 - Americano
 - Coffee
 - Αφαλάτωση
- B9. Λυχνία «αφαλάτωση»
- B10. Λυχνία «έτοιμος ατμός»
- B11. Λυχνία «απουσία δοχείου για κόκκους»
- B12. Λυχνία «εξοικονόμηση ενέργειας»
- B13. Λυχνία «Καθαρισμός» (δείτε «8.1 Καθαρισμός του ακροφυσίου καφέ»)
- B14. Λυχνία «άδειο δοχείο για κόκκους»
- B15. Λυχνία «απουσία νερού»
- B16. Λυχνία «πίεση»
- B17. Μανόμετρο

1.3 Περιγραφή των εξαρτημάτων - C

- C1. Κύπελλο θήκης φίλτρου
- C2. Φίλτρο 1 φλιτζανιού
- C3. Φίλτρο 2 φλιτζανιών
- C4. Δοκιμαστική ταινία «Total Hardness Test»
- C5. Αφαλατικό
- C6. Αποσπώμενο ηλεκτρικό καλώδιο
- C7. Βουρτσάκι
- C8. Εξάρτημα καθαρισμού ακροφυσίου καφέ
- C9. Softballs
- C10. Μπρίκι γάλακτος
- C11. Βελόνα καθαρισμού για ακροφύσιο ατμού

1.4 Τα εξαρτήματα καθαρισμού δεν περιλαμβάνονται, συνιστώνται από τον κατασκευαστή

Για περισσότερες πληροφορίες, επισκεφθείτε το Delonghi.com.

Ταμπλέτες καθαρισμού

(Δείτε «8.1 Καθαρισμός του ακροφυσίου καφέ»)



EcoMultiClean Απορρυπαντικό
EAN: 8004399333307

2. ΠΡΟΕΤΟΙΜΑΣΙΑ ΤΗΣ ΣΥΣΚΕΥΗΣ

Πλύνετε όλα τα εξαρτήματα με χλιαρό νερό και απορρυπαντικό πιάτων, στη συνέχεια, προχωρήστε με τον ακόλουθο τρόπο:

1. Τοποθετήστε το δοχείο για κόκκους (A2) στον μύλο άλεσης καφέ (εικ. 1). Το δοχείο τοποθετείται σωστά όταν το βέλος ▲ ευθυγραμμίζεται με το σύμβολο ☐ και ακούγεται ένα «κλικ» (εικ. 2).
2. Τοποθετήστε το δίσκο συλλογής σταγόνων (A10) μαζί με τη σχάρα φλιτζανιών (A8) και τη σχάρα δίσκου (A9) (εικ. 3).
3. Αφαιρέστε το δοχείο νερού (A14) (εικ. 4) και γεμίστε το με φρέσκο και καθαρό νερό με προσοχή ώστε να μην ξεπεράσετε την επιγραφή MAX (εικ. 5).
4. Στη συνέχεια εισάγετε το δοχείο.

Προσοχή: Μην θέτετε ποτέ σε λειτουργία τη συσκευή χωρίς νερό στο δοχείο ή χωρίς δοχεία.

Σημαντικό: Συνιστάται να ρυθμίσετε το ταχύτερο δυνατόν τη σκληρότητα του νερού σύμφωνα με τη διαδικασία που περιγράφει το κεφάλαιο «7. ΜΕΝΟΥ ΡΥΘΜΙΣΕΙΣ».

3. ΑΡΧΙΚΗ ΛΕΙΤΟΥΡΓΙΑ ΤΗΣ ΣΥΣΚΕΥΗΣ

1. Συνδέστε το καλώδιο τροφοδοσίας (C6) στην αντίστοιχη θέση (A16) στο πίσω μέρος του μηχανήματος (εικ. 6) και στη συνέχεια βάλτε το καλώδιο στην πρίζα. Βεβαιωθείτε ότι ο γενικός διακόπτης (A17), που βρίσκεται στο πίσω μέρος της μηχανής είναι πατημένος στη θέση I (εικ. 7)
2. Τοποθετήστε κάτω από το ακροφύσιο ζεστού νερού (σε αντιστοιχία με το ακροφύσιο καφέ (A18)) ένα δοχείο ελάχιστης χωρητικότητας 100 ml (εικ. 8).

3. Πατήστε το πλήκτρο (B6) που αντιστοιχεί στη λυχνία (☺) (εικ. 9): η παροχή αρχίζει και διακόπεται αυτόματα. Αδειάζετε το δοχείο.

Πριν ξεκινήσετε τη χρήση της μηχανής πρέπει να ξεπλύνετε τα εσωτερικά κυκλώματά της. Ακολουθήστε τον παρακάτω τρόπο:

4. Συνδέστε ολόκληρο το κύπελλο θήκης φίλτρου (C1) στη μηχανή: για τη σωστή σύνθεση ευθυγραμμίστε τη λαβή του κυπέλλου θήκης φίλτρου στο σύμβολο «INSERT» (εικ. 10) και στρέψτε τη λαβή προς τα δεξιά μέχρι να την ευθυγραμμίσετε στη θέση «CLOSE».
5. Τοποθετήστε ένα δοχείο κάτω από το κύπελλο υποδοχής του φίλτρου και στον σωλήνα παροχής ατμού (A6).
6. Πιέστε το πλήκτρο OK (B5) (εικ. 11): η παροχή ξεκινά.
7. Μόλις ολοκληρωθεί η παροχή, περιστρέψτε τον διακόπτη ατμού (A4) (εικ. 12) και αφήστε να βγει ατμός για μερικά δευτερόλεπτα έτσι ώστε να ξεπλυθεί το κύκλωμα του ατμού: για να έχετε την βέλτιστη παροχή ατμού, συνιστάται να επαναλάβετε αυτή την ενέργεια 3 ή 4 φορές. Αυτό επιτρέπει την απομάκρυνση του νερού του σωλήνα πριν την παροχή ατμού.

Η μηχανή είναι τώρα έτοιμη για χρήση.

Σημαντικό: το ξεβγάλμα των εσωτερικών κυκλωμάτων συνιστάται και σε περίπτωση παρατεταμένης περιόδου αχρησίας της μηχανής.

Κατά την πρώτη χρήση, θα πρέπει πρώτα να παρασκευάσετε 4-5 καφέδες προκειμένου το μηχάνημα να αρχίσει να δίνει ικανοποιητικό αποτέλεσμα: δώστε ιδιαίτερη προσοχή στη δόση του αλεσμένου καφέ στο φίλτρο ((C2) ή (C3)) (δείτε οδηγίες στην παράγραφο «4.1 Στάδιο 1 - Άλεση (grinding)»).

προχωρήστε όπως υποδεικνύεται στο κεφάλαιο «Η «τέλεια δόση»».

4. ΠΡΟΕΤΟΙΜΑΣΙΑ ΤΟΥ ΚΑΦΕ

4.1 Στάδιο 1 - Άλεση (grinding)

1. Ρίξτε τους κόκκους μέσα στο δοχείο (A2) (εικ. 13). Συνιστάται να ρίχνετε μόνο τους κόκκους που απαιτούνται για την παρασκευή: με αυτόν τον τρόπο χρησιμοποιείτε πάντα φρέσκο καφέ.
2. Επιλέξτε τον βαθμό άλεσης (εικ. 14). Η εργοστασιακή ρύθμιση είναι στο 5 (μέτρια άλεση). Αν το αποτέλεσμα δεν είναι ικανοποιητικό, ρυθμίστε το επίπεδο με βάση την προσωπική σας προτίμηση και τον τύπο του καφέ (η ρύθμιση πρέπει να πραγματοποιείται κατά τη διάρκεια λειτουργίας του μύλου καφέ).

Σημαντικό: Ο βαθμός άλεσης από 3 έως 6 είναι αυτός που συνιστάται για τους περισσότερους καφέδες. Επιλέγοντας βαθμό άλεσης 1 ή 2, το αποτέλεσμα της άλεσης θα είναι πολύ λεπτό και πρέπει να χρησιμοποιείται μόνο σε πολύ ιδιαίτερες περιπτώσεις καφέ (ελαφρύ καβούρδισμα).

3. Εισάγετε ένα από τα φίλτρα του καφέ (C2) ή (C3) μέσα στη θήκη του φίλτρου (C1) (εικ. 15). Αν χρησιμοποιήσετε το φίλ-

τρο για τα 2 φλιτζάνια, πατήστε το κουμπί X2 (B3): με αυτή την επιλογή διπλασιάζεται και η ποσότητα του espresso που παράχεται.

4. Ρυθμίστε τον διακόπτη της ποσότητας (B2) ξεκινώντας από την ελάχιστη θέση (εικ. 16).

Συμβουλευτείτε την παράγραφο «Ρυθμίστε την ποσότητα του αλεσμένου καφέ στο φίλτρο» για περισσότερες οδηγίες.

5. Συνδέστε το κύπελλο με το φίλτρο στην έξοδο του μύλου καφέ (A19) ευθυγραμμίζοντάς το με την ένδειξη INSERT: στη συνέχεια περιστρέψτε το κύπελλο προς τα δεξιά. Η άλεση ξεκινά όταν το κύπελλο φτάσει στη θέση CLOSE και διακόπεται αυτόματα.

Ρυθμίστε την ποσότητα του αλεσμένου καφέ στο φίλτρο



Κάθε ποικιλία κόκκου δίνει διαφορετικό αποτέλεσμα κατά τη διάρκεια της άλεσης και γι' αυτό στην αρχή η ρύθμιση της δόσης απαιτεί εξαιρετική προσοχή.

Η εικόνα αυτή δίνει οδηγίες ως προς τη ρύθμιση της δόσης, με βάση το χρώμα του ψησίματος: πρέπει να θεωρούνται σημείο εκκίνησης, ωστόσο ενδέχεται να διαφέρουν ανάλογα με τη σύνθεση των κόκκων του καφέ.

1. Ρυθμίστε τη δόση από την ελάχιστη θέση.
2. Έχοντας ως αναφορά το χρώμα ψησίματος του καφέ σας, περιστρέψτε αργά το κουμπί.

4.2 Στάδιο 2 - Πίεση (tamping)

1. Μετά την άλεση, κατεβάστε τον μοχλό πίεσης του καφέ (A20) μέχρι το τέρμα (μην αφαιρείτε το κύπελλο με το φίλτρο) (εικ. 17).. Για να έχετε τέλειο αποτέλεσμα, επαναλάβετε 2 φορές.
2. Κρατήστε χαμηλωμένο τον μοχλό ως το τέρμα της διαδρομής κατά τη διάρκεια της αφαίρεσης της θήκης φίλτρου (εικ. 18). Επειτα επαναφέρετε τον μοχλό στην αρχική θέση.
3. Μόλις επιβεβαιώσετε ότι η δόση του καφέ είναι σωστή (δείτε «Η «τέλεια δόση»»), συνδέστε τη θήκη του φίλτρου στο ακροφύσιο καφέ (A18) (εικ. 19).

Σημαντικό: Εάν μετά το πάτημα του καφέ παραμείνουν υπολείμματα καφέ κατά μήκος του χειλούς του φίλτρου, αυτό δεν επηρεάζει καθόλου την ποιότητα της εκχύλισης και ως εκ τούτου και το τελικό αποτέλεσμα.

Η «τέλεια δόση»

- Τα φίλτρα του καφέ διαθέτουν εσωτερική ένδειξη αναφοράς για τον προσδιορισμό της τέλει δόσης.



Χάραξη με λείζερ

Ανάγλυφη χάραξη

- Φίλτρα με χάραξη λείζερ: η τέλεια δόση αντιστοιχεί στην πάνω γραμμή της χάραξης.
- Φίλτρα με ανάγλυφη χάραξη: η τέλεια δόση αντιστοιχεί στην ανάγλυφη γραμμή.
- Βεβαιωθείτε ότι ο καφές είναι σε αυτό το επίπεδο μετά το πάτημα. Μπορεί να χρειαστεί να ρυθμίσετε περισσότερες φορές το κουμπί (B2) προτού φτάσετε στην τέλεια δόση.
- Αν ο καφές υπερ- ή υπο-εκχυλίζεται και η δόση βρίσκεται εντός της τέλει δόσης, ρυθμίστε τον βαθμό άλεσης σε πιο λεπτό ή πιο χοντρό (δείτε «4.1 Στάδιο 1 - Άλεση (grinding)»). Αν ο καφές υπερ-εκχυλίζεται (πολύ αργή παροχή) η άλεση πρέπει να είναι πιο χοντρή. Αν ο καφές υπο-εκχυλίζεται (πολύ γρήγορη παροχή) η άλεση πρέπει να είναι πιο λεπτή.
- **Ο μπανίστα συνιστά:** Βγάλτε τη θήκη του φίλτρου ενώ ο μοχλός του πατητηριού (A20) είναι χαμηλωμένος για να έχετε ένα τέλει φινίρισμα της δόσης του καφέ.
- **Εάν χρησιμοποιείται προαλεσμένος καφές:**
 - ρίξτε τον προαλεσμένο καφέ στο φίλτρο,
 - περιστρέψτε τον διακόπτη στο ,
 - συνδέστε την υποδοχή του φίλτρου στην έξοδο του μύλου άλεσης καφέ,
 - χαμηλώστε τον μοχλό πίεσης.

4.3 Στάδιο 3 - Παροχή (brewing)

1. Επιλέξτε τη θερμοκρασία (εικ. 20) (δείτε «Η θερμοκρασία για την προετοιμασία του καφέ»).
2. Επιλέξτε το επιθυμητό ρόφημα (εικ. 21).
3. Πατήστε OK (B5) για να ξεκινήσει η παροχή (εικ. 11) (προ-έγχυση και έγχυση). Η παροχή του καφέ διακόπτεται αυτόματα.

Η θερμοκρασία για την προετοιμασία του καφέ

Η θερμοκρασία του νερού ελέγχεται καθ' όλη τη διάρκεια της διαδικασίας προετοιμασίας προκειμένου να εξασφαλίζεται η σταθεροποίηση της στο στάδιο της εκχύλισης. Η Specialista Prestigio προσφέρει 3 θερμοκρασίες έγχυσης* που αντιστοιχούν σε εύρος μεταξύ 92°C και 96°C.

Ανάλογα με την ποικιλία και το ψήσιμο των κόκκων, συνιστάται διαφορετική θερμοκρασία: οι κόκκοι Robusta απαιτούν χαμηλή θερμοκρασία, ενώ οι κόκκοι Arabica απαιτούν υψηλή θερμοκρασία. Το ίδιο ισχύει για τους κόκκους με σκούρο ψήσιμο ή για τους ελαφρώς ψημένους κόκκους.

Επίπεδο θερμοκρασίας	Αντίστοιχη λυχνία	Επίπεδο ψησίματος
ΕΛΑΧΙΣΤΟ		Σκούρο
ΜΕΤΡΙΟ		Μέτριο - σκούρο
ΜΕΓΙΣΤΟ		Ανοιχτό - Μέτριο

- * Αυτή η θερμοκρασία αναφέρεται στο νερό μέσα στο θερμομπλόκ. Επομένως διαφέρει από τη θερμοκρασία του ροφήματος στο φλιτζάνι ή από τη θερμοκρασία που μετρείται όταν το ρόφημα βγαίνει από τα ακροφύσια του κυπέλλου με την υποδοχή του φίλτρου.

5. ΠΡΟΕΤΟΙΜΑΣΙΑ ΡΟΦΗΜΑΤΩΝ ΓΑΛΑΚΤΟΣ

5.1 Προετοιμασία του αφρόγαλου

1. Ρίξτε στο μπρίκι (C10) την ποσότητα γάλακτος που θέλετε να ζεστανέτε/να αφρίσετε, λαμβάνοντας υπόψη ότι ο όγκος του γάλακτος θα αυξηθεί κατά 2 ή 3 φορές (εικ. 22). Για να έχετε πιο πυκνό και ομοιογενή αφρό, συνιστάται η χρήση πλήρους αγελαδινού γάλακτος σε θερμοκρασία ψυγείου (περίπου 5° C).

My Latte Art

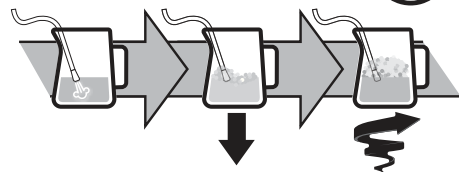

2. Για να φτιάξετε το αφρόγαλο, τοποθετήστε τον σωλήνα παροχής ατμού (A6) πάνω στην επιφάνεια του γάλακτος: με αυτόν τον τρόπο ο αέρας ανακατεύεται με το γάλα και τον ατμό.
3. Διατηρήστε το ακροφύσιο του ατμού πάνω στην επιφάνεια, φροντίζοντας να μην λαμβάνετε πάρα πολύ αέρα δημιουργώντας πολύ μεγάλες φουσκάλες.
4. Βυθίστε το ακροφύσιο ατμού κάτω από την επιφάνεια του γάλακτος: με αυτόν τον τρόπο δημιουργείται μια δίνη. Μόλις επιτευχθεί η επιθυμητή θερμοκρασία, ξανακλείστε τον διακόπτη ατμού και περιμένετε έως ότου η παροχή του

ατμού σταματήσει εντελώς προτού αφαιρέσετε το μπρίκι με το γάλα.

Ο μπαρίστα συνιστά:

- **Το φρέσκο γάλα είναι καλύτερο.** Χρησιμοποιείτε πάντα φρέσκο γάλα σε θερμοκρασία ψυγείου.
- Για ένα καλύτερο αποτέλεσμα, συνιστάται να ξαναβάζετε πάντα το μπρίκι του γάλακτος μέσα στο ψυγείο.
- Το πλήρες γάλα δίνει άριστα αποτελέσματα. Το αποτέλεσμα και η υφή του αφρού διαφέρουν ανάλογα με το αγελαδινό γάλα ή με τα φυτικά ροφήματα που χρησιμοποιούνται.
- Αφού φτιάξετε το αφρόγαλα, απομακρύνετε τις φουσκάλες ανακινώντας κυκλικά με ελαφρές κινήσεις το μπρίκι με το γάλα.

Καθαρισμός του ακροφυσίου ατμού:







1. Μετά από κάθε χρήση, αφαιρείτε με ένα πανί τα υπολείμματα του γάλακτος από το ακροφύσιο του ατμού (εικ. 23). Για ένα βαθύ καθαρίσμο, συνιστάται η χρήση του Eco MultiClean: εξασφαλίζει την υγιεινή αφαιρώντας τις πρωτεΐνες και τα λίπη του γάλακτος και μπορεί να χρησιμοποιηθεί για τον καθαρισμό ολόκληρης της μηχανής.
2. Αφήστε να βγει ατμός για μερικά δευτερόλεπτα ώστε να καθαριστεί καλά το ακροφύσιο (εικ. 12).
3. Περιμένετε έως ότου το ακροφύσιο κρυώσει: για να διατηρήσετε την αποτελεσματικότητα του ακροφυσίου με το πέρας του χρόνου, χρησιμοποιήστε τη βελόνα καθαρισμού (C11) για να διατηρείτε ελεύθερες τις 3 οπές (εικ. 24).

6. ΕΞΑΤΟΜΙΚΕΥΣΗ ΤΗΣ ΠΟΣΟΤΗΤΑΣ ΤΩΝ ΡΟΦΗΜΑΤΩΝ ΚΑΦΕ ΜΕ ΤΟ ΚΟΥΜΠΙ (my) (B7)



1. Ετοιμάστε τη μηχανή για την παροχή 1 ή 2 φλιτζανιών του ροφήματος καφέ που επιθυμείτε, μέχρι να συνδεθεί η θήκη του φίλτρου (C1) μαζί με το φίλτρο (C2) ή (C3) τον αλεσμένο καφέ.
2. Περιστρέψτε τον διακόπτη (B8) για να επιλέξετε το ρόφημα που θα προγραμματίσετε.
3. Πατήστε το κουμπί (my): η λυχνία που αντιστοιχεί στο κουμπί (my) αναβοσβήνει.
4. Πατήστε το κουμπί OK για να ξεκινήσει η παροχή. Οι λυχνίες που αντιστοιχούν στα κουμπιά OK και (my) αναβοσβήνουν.
5. Μόλις επιτευχθεί η επιθυμητή ποσότητα, πατήστε OK. Αν το ρόφημα προβλέπει την παροχή και κάποιου άλλου συστατικού, ξεκινά η παροχή αυτού: μόλις επιτευχθεί η επιθυμητή ποσότητα, πατήστε OK.
6. Πατήστε το κουμπί (my) για αποθήκευση. Η συσκευή είναι έτοιμη για νέα χρήση και η λυχνία (my) παραμένει αναμμένη. Αν δεν επιθυμείτε να αποθηκεύσετε τον προγραμματισμό, πατήστε οποιοδήποτε άλλο κουμπί.



Σημαντικό:

- Μπορείτε να προγραμματίσετε τα ροφήματα καφέ, αλλά όχι την παροχή ατμού και ζεστού νερού.
- Ο προγραμματισμός αλλάζει τις ποσότητες των ροφημάτων, αλλά όχι του αλεσμένου καφέ.
- Τα ροφήματα «X2» μπορούν να προγραμματιστούν ξεχωριστά.
- **Για να επιστρέψετε στις εργοστασιακές ρυθμίσεις, κρατήστε πατημένο το πλήκτρο (my) μέχρι να σβήσει. Το επιλεγμένο ρόφημα επανέρχεται στην εργοστασιακή ποσότητα.**



Συνταγή καφέ	Εργοστασιακή ποσότητα	Προγραμματιζόμενη ποσότητα
 Espresso	35 ml	από 25 έως 90 ml
 X2	70 ml	από 50 έως 180 ml
 Coffee	80 ml	από 50 έως 120 ml
 X2	160 ml	από 120 έως 240 ml
 Americano	120 ml	<ul style="list-style-type: none"> • espresso: από 25 έως 60 ml • νερό: από 25 έως 120 ml
 X2	240 ml	<ul style="list-style-type: none"> • espresso: από 50 έως 120 ml • νερό: από 50 έως 240 ml

7. ΜΕΝΟΥ ΡΥΘΜΙΣΕΙΣ

1. Μπίετο στο μενού:		
Πατήστε ταυτόχρονα για 5 δευτερόλεπτα	x2	(my)
2. Ρυθμίσεις με επιλογή μέσω διακόπτη (B8)		
		
Αντίστοιχη ρύθμιση	Περιστρέψτε στο	Ρυθμίσεις
Έξτρα ρύθμιση της άλεσης		x2 ➔ Πεδίο 1
		☰ ➔ Πεδίο 2
➔		

Σκληρότητα νερού	 Americano	×2 ➔ μαλακό
		☰ ➔ μέτριο
		OK ➔ σκληρό/πολύ σκληρό
Αυτόματο σβήσιμο	 Coffee	×2 ➔ 9 λεπτά
		☰ ➔ 1,5 ώρες
		OK ➔ 3 ώρες

3. Ρύθμιση με επιλογή μέσω πλήκτρου:

Εξοικονόμηση ενέργειας	 ➔ Ενεργό
	 ➔ Ανενεργό
Εργοστασιακές ρυθμίσεις	Κρατήστε πατημένο για τουλάχιστον 5 δευτερόλεπτα το πλήκτρο  , έως ότου η λυχνία παραμείνει σταθερά αναμμένη

4. Αποθηκεύστε τις νέες ρυθμίσεις πατώντας ON/Standby (B1)

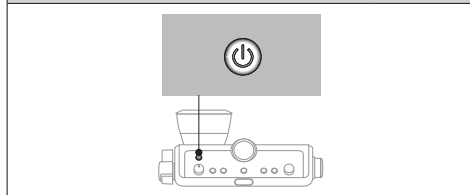











8. ΚΑΘΑΡΙΣΜΟΣ ΤΗΣ ΣΥΣΚΕΥΗΣ

Προσοχή!

- Για τον καθαρισμό της μηχανής, μη χρησιμοποιείτε διαλύτες ή διαβρωτικά απορρυπαντικά ή αλκοόλ.
- Μη χρησιμοποιείτε μεταλλικά αντικείμενα για να αφαιρέσετε τα άλατα ή τα κατακάθια καφέ γιατί μπορεί να γρατζουνιστούν οι μεταλλικές ή πλαστικές επιφάνειες.
- Σε περίπτωση που δεν έχετε χρησιμοποιήσει τη μηχανή για πάνω από μία εβδομάδα συνιστάται, προτού την επαναχρησιμοποιήσετε, να εκτελέσετε ένα ξεβγάλμα.



Κίνδυνος!

- Κατά τον καθαρισμό, μη βυθίζετε ποτέ τη συσκευή σε νερό: είναι ηλεκτρική συσκευή.
- Πριν από οποιαδήποτε εργασία καθαρισμού των εξωτερικών μερών της συσκευής, σβήστε τη μηχανή, αποσυνδέστε το φις από την πρίζα του ρεύματος και αφήστε τη μηχανή να κρυώσει.

	 DISHWASHER	 Eco MultiClean			
	×	✓	✓	×	×
	✓	×	×	✓	✓
	×	×	×	✓	✓
	×	×	×	✓	✓
	×	×	✓	✓	×
	×	×	×	✓	✓

8.1 Καθαρισμός του ακροφυσίου καφέ



Όταν ανάβει η λυχνία  (πορτοκαλί) (B13), είναι απαραίτητο να προχωρήσετε στον καθαρισμό του κυκλώματος του καφέ. Για να εκτελέσετε τον κύκλο καθαρισμού, προμηθευτείτε τις ταμπλέτες καθαρισμού για μηχανή καφέ. Για περισσότερες πληροφορίες, επισκεφθείτε το www.Delonghi.com.

1. Τοποθετήστε το φίλτρο 1 φλιτζανιού (C2) στη θήκη του φίλτρου (C1) (εικ. 25).
2. Τοποθετήστε στο φίλτρο το εξάρτημα καθαρισμού (C8) (εικ. 25) και πιέστε το καλά.
3. Εισάγετε την ταμπλέτα καθαρισμού στο εξάρτημα (εικ. 26).
4. Συνδέστε τη θήκη του φίλτρου στο ακροφύσιο καφέ (A18).
5. Γεμίστε το δοχείο νερού (A14). Βεβαιωθείτε ότι ο δίσκος συλλογής σταγόνων (A10) είναι άδειος.
6. Κρατήστε πατημένο το πλήκτρο  (B6), μέχρι να ανάψει η λυχνία  (B13). Ύστερα από μερικά λεπτά, ο καθαρισμός σταματά αυτόματα.
7. Αφαιρέστε τη θήκη του φίλτρου και το εξάρτημα καθαρισμού.
8. Πλύνετε τη θήκη του φίλτρου και το φίλτρο με νερό βρύσης.
9. Ξαναβάλτε το κύπελλο του φίλτρου και προχωρήστε σε ξεβγάλμα πατώντας το κουμπί  : συνιστάται η τοποθέτηση ενός δοχείου κάτω από το κύπελλο του φίλτρου.
10. Αφαιρέστε και αδειάστε τον δίσκο συλλογής σταγόνων.

Σημαντικό:

Αυτός ο κύκλος καθαρισμού μπορεί να τεθεί σε εκκίνηση οποιαδήποτε στιγμή πατώντας το κουμπί  για μερικά δευτερόλεπτα. Για να ακυρώσετε την ενέργεια, πατήστε το κουμπί για 10 δευτερόλεπτα.

8.2 Καθαρίστε την υποδοχή του δοχείου για κόκκους

1. Βεβαιωθείτε ότι το δοχείο για κόκκους (A2) είναι άδικο. Ενδεχομένως εκτελέστε μερικές αλέσεις εν κενώ για να το αδειάσετε.
2. Αποσυνδέστε το δοχείο περιστρέφοντάς το αριστερόστροφα και τραβήξτε το από τη μηχανή (εικ. 27)
3. Αναρροφήστε τα υπολείμματα του καφέ (εικ. 28)
4. Καθαρίστε με ένα υγρό πανί την υποδοχή του δοχείου κόκκων και στεγνώστε (εικ. 29).
5. Ξαναβάλτε το δοχείο στη θέση του συνδέοντάς το στον μύλο του καφέ. Το δοχείο τοποθετείται σωστά όταν το βέλος  είναι ευθυγραμμισμένο με το σύμβολο  και ακούγεται ένα «κλικ» (εικ.30).

8.3 Καθαρισμός των μύλων

Όταν καθαρίζετε το δοχείο των κόκκων (A2), καθαρίζετε την υποδοχή του δοχείου και τον μύλο στο πάνω μέρος με ένα υγρό πανί. Απευθυνθείτε σε ένα κέντρο υποστήριξης για να αφαιρέσετε και να αντικαταστήσετε τους μύλους άλεσης.

Μπορείτε να αφαιρέσετε τον μύλο άλεσης σε περίπτωση που ο μύλος του καφέ μπλοκάρει εξαιτίας κάποιου ξένου σώματος. Εάν συμβεί κάτι τέτοιο, αφαιρέστε το δοχείο για κόκκους και προχωρήστε ως εξής:

1. Συνδέστε το κύπελλο θήκης φίλτρου (C1) και εκτελέστε μια άλεση «εν κενώ» για να ελευθερωθεί η διόδος του καφέ.
2. Απενεργοποιήστε τη συσκευή.
3. Περιστρέψτε αριστερόστροφα τον ρυθμιστή άλεσης μέχρι το τέρμα, στη θέση «REMOVE» (εικ. 31).
4. Αφαιρέστε το πάνω μέρος του μύλου άλεσης, πιάνοντάς τον καλά από την ειδική λαβή (εικ.32).
5. Καθαρίστε τον μύλο με ένα πινέλο (εικ. 33) και αναρροφήστε το υπόλειμμα καφέ με μια ηλεκτρική σκούπα (εικ. 28).

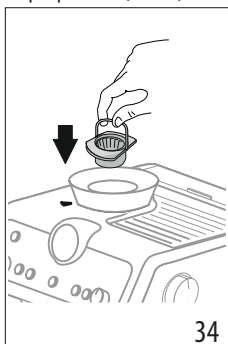
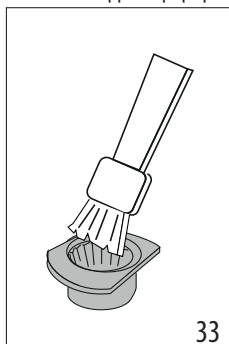

6. Εισάγετε τον μύλο στη θέση του (εικ. 34).
7. Περιστρέψτε τον ρυθμιστή επιλέγοντας τον βαθμό άλεσης που επιθυμείτε (εικ. 14).

Βεβαιωθείτε ότι ο μύλος άλεσης έχει τοποθετηθεί σωστά, τραβώντας τον από τη λαβή: ο μύλος άλεσης έχει τοποθετηθεί σωστά όταν αυτός δεν κινείται.

8.4 Αντικατάσταση των μύλων άλεσης

Όταν η ποσότητα του αλεσμένου καφέ μειωθεί κι άλλο, απευθυνθείτε σε ένα κέντρο υποστήριξης για να αντικαταστήσετε τους μύλους άλεσης: έπειτα ρυθμίστε εκ νέου τον μύλο του καφέ μπαίνοντας στο μενού Ρυθμίσεις («7. ΜΕΝΟΥ ΡΥΘΜΙΣΕΙΣ») και επιλέγοντας το πρώτο πεδίο της έξτρα ρύθμισης της άλεσης. Έπειτα, περιστρέψτε το κουμπί ρύθμισης ποσότητας (B2) στη θέση MIN και ρυθμίστε τη δόση όπως κατά την πρώτη χρήση (δείτε «τέλεια δόση»).

8.5 Καθαρισμός του «Smart tamping station»

1. Καθαρίστε την περιοχή σύνδεσης με ένα πινέλο (εικ. 35).
2. Τραβήξτε τον μοχλό (A20) μέχρι το τέρμα της διαδρομής, καθαρίστε με ένα πινέλο το πατητήρι (εικ. 36) και έπειτα αφήστε τον μοχλό.
3. Με ένα σκουπάκι (C7), καθαρίστε την έξοδο του καφέ (εικ. 37).

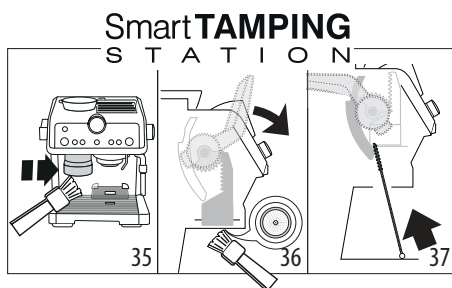

9. ΣΚΛΗΡΟΤΗΤΑ ΝΕΡΟΥ

Η λυχνία  (B9) αφαλάτωσης ανάβει μετά από ένα προκαθορισμένο διάστημα λειτουργίας που εξαρτάται από τη σκληρότητα του νερού. Μπορείτε να προγραμματίσετε τη μηχανή βάσει της πραγματικής σκληρότητας του νερού στις αντίστοιχες περιοχές, κάνοντας λιγότερο τακτική, με τον τρόπο αυτό, τη διαδικασία αφαλάτωσης.

1. Βγάλτε από τη συσκευασία της την ταινία αντίδρασης «TOTAL HARDNESS TEST» (C4).
2. Βυθίστε την εντελώς σε ένα ποτήρι νερό για ένα δευτερόλεπτο περίπου.
3. Αφαιρέστε την ταινία από το νερό και τινάξτε την ελαφρά. Ρυθμίστε τη συσκευή όπως υποδεικνύεται στο κεφάλαιο «7. ΜΕΝΟΥ ΡΥΘΜΙΣΕΙΣ».

Αποτέλεσμα Σκληρότητας Νερού	Δοκιμής	Κουμπί	Στάθμη
		x2	1 μαλακό νερό
			2 μέτριο νερό
			3 σκληρό ή πολύ σκληρό νερό

4. Ρυθμίστε τη συσκευή όπως υποδεικνύεται στο κεφάλαιο «7. ΜΕΝΟΥ ΡΥΘΜΙΣΕΙΣ».

10. ΠΩΣ ΝΑ ΧΡΗΣΙΜΟΠΟΙΗΣΕΤΕ ΤΑ SOFTBALLS

Τα Softballs (C9) είναι ένα καινοτόμο σύστημα που επιμηκύνει τη διάρκεια ζωής της μηχανής, χωρίς να αλλοιώνει την ποιότητα του νερού, εξασφαλίζοντας έναν κρεμώδη και αρωματικό καφέ. Για να βελτιστοποιήσετε την αποτελεσματικότητα, αφήστε τα Softballs στο νερό για μια ολόκληρη νύχτα πριν από τη χρήση.

1. Βγάλτε το πακέτο με τα Softballs μέσα από τη συσκευασία (εικ. 38).

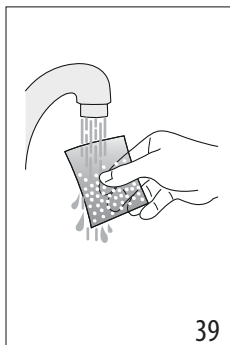
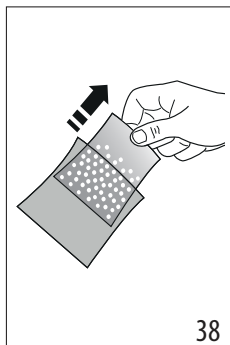

2. Ξεπλύνετε με νερό βρύσης το πακέτο με τα Softballs (εικ. 39).
3. Βυθίστε το σακουλάκι μέσα στο δοχείο νερού (A14) (εικ. 40).

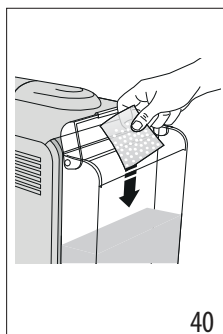

40

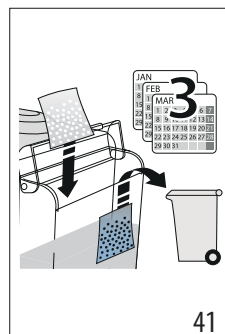

41

4. Αντικαθιστάτε το σακουλάκι με τα Softballs κάθε 3 μήνες (εικ. 41).

11. ΑΦΑΛΑΤΩΣΗ

Προσοχή!

- Πριν από τη χρήση, διαβάστε τις οδηγίες και την ετικέτα του αφαλατικού (C5) που αναγράφονται στη συσκευασία του.
- Συνιστάται η αποκλειστική χρήση υγρών καθαρισμού αλάτων De'Longhi. Η χρήση των ακατάλληλων προϊόντων αφαλάτωσης, όπως και η ίδια η αφαλάτωση που δεν εκτελείται τακτικά, μπορεί να δημιουργήσει βλάβες που δεν καλύπτει η εγγύηση του κατασκευαστή.
- Το αφαλατικό υγρό ενδέχεται να προκαλέσει ζημιά στις ευαίσθητες επιφάνειες. Αν το προϊόν αναποδογυρίσει κατά λάθος, στεγνώστε αμέσως.

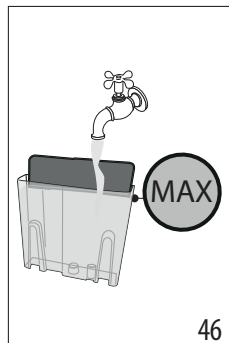
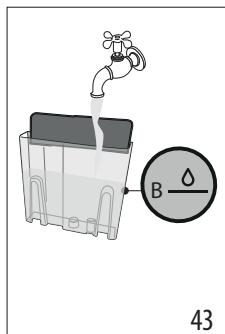
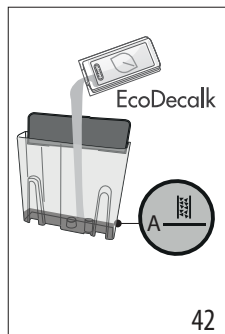

Για εκτέλεση αφαλάτωσης	
Αφαλατικό	Αφαλατικό De'Longhi
Δοχείο	Χωρητικότητα 2 λίτρα
Χρόνος	~40 λεπ.

1. (ΑΝ ΥΠΑΡΧΟΥΝ, ΑΦΑΙΡΕΣΤΕ ΤΟ ΦΙΛΤΡΟ ΑΠΟΣΚΛΗΡΥΝΣΗΣ ΚΑΙ ΤΑ SOFTBALLS). Ρίξτε στο δοχείο νερού (A14) το αφαλατικό μέχρι το επίπεδο **A** (αντιστοιχεί σε μια συσκευασία των 100ml), το οποίο αναγράφεται στην εσωτερική πλευρά του δοχείου (εικ. 42).

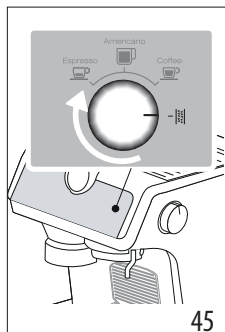
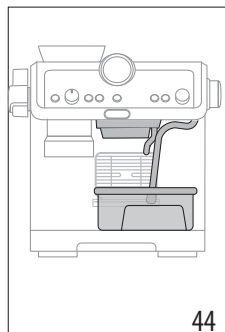

2. Προσθέστε νερό μέχρι το επίπεδο  B (εικ. 43). Στη συνέχεια ξαναβάλτε το δοχείο νερού στη μηχανή.



3. Βεβαιωθείτε ότι το κύπελλο υποδοχής του φίλτρου (C1) δεν είναι συνδεδεμένο και τοποθετήστε ένα δοχείο κάτω από τα ακροφύσια του καφέ και του ζεστού νερού και κάτω από το ακροφύσιο του ατμού (A6) (εικ. 44).
4. Περιστρέψτε τον διακόπτη (B8) στο  (εικ. 45): η λυχνία OK ανάβει με πορτοκαλί χρώμα; η λυχνία  αναβοσβήνει.
5. Πατήστε το κουμπί OK: η λυχνία OK αναβοσβήνει.
6. Το πρόγραμμα αφαλάτωσης ξεκινά και το αφαλατικό υγρό βγαίνει από τα ακροφύσια. Το πρόγραμμα αφαλάτωσης εκτελεί αυτόματα μια σειρά από ξεβγάλματα ανά διαστήματα, για να αφαιρέσετε τα υπολείμματα αλάτων από το εσωτερικό της μηχανής του καφέ μέχρι να αδειάσει το δοχείο.

Η παροχή διακόπτεται και η λυχνία OK γίνεται άσπρη. Στη συνέχεια είναι απαραίτητο να προχωρήσετε στον κύκλο ξεβγάλματος:

7. Αδειάστε το δοχείο που χρησιμοποιείται για τη συλλογή του υγρού αφαλάτωσης και τοποθετήστε το ξανά κάτω από τα ακροφύσια.
8. Αφαιρέστε το δοχείο νερού, αδειάστε το από τυχόν υπολείμματα αφαλατικού διαλύματος, ξεπλύνετε το με νερό βρύσης και γεμίστε το με φρέσκο νερό μέχρι το επίπεδο MAX (εικ. 46). Τοποθετήστε ξανά το δοχείο στη θέση του.











9. Πατήστε το κουμπί OK: το ξεβγάλμα ξεκινά.
10. Μόλις ολοκληρωθεί το ξεβγάλμα, η παροχή σταματά και η συσκευή είναι έτοιμη για χρήση.
11. Αδειάστε τα δοχεία συλλογής του νερού ξεβγάλματος.
12. Αφαιρέστε και αδειάστε το δοχείο συλλογής σταγόνων και στη συνέχεια εισάγετέ το ξανά.
13. Αφαιρέστε και γεμίστε το δοχείο με φρέσκο νερό, και στη συνέχεια τοποθετήστε το ξανά.

Η μηχανή τώρα είναι έτοιμη για χρήση.





Σημαντικό:







- Μπορείτε να ξεκινήσετε τον κύκλο αφαλάτωσης οποιαδήποτε στιγμή (ακόμη και αν η σχετική λυχνία δεν έχει ακόμα ανάψει).
- Σε περίπτωση που η αφαλάτωση έχει ξεκινήσει κατά λάθος, πατήστε το κουμπί OK για 10 δευτερόλεπτα. Το ξεβγάλμα δεν μπορεί να διακοπεί.

12. ΕΠΕΞΗΓΗΣΗ ΤΩΝ ΛΥΧΝΙΩΝ

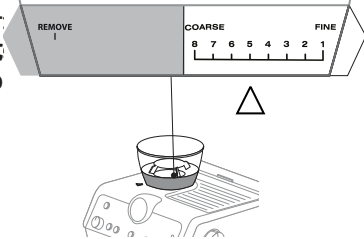



ΛΥΧΝΙΣ	ΕΠΕΞΗΓΗΣΗ ΤΩΝ ΛΥΧΝΙΩΝ	ΕΝΕΡΓΕΙΑ
Όλες οι λυχνίες αναβοσβήνουν σύντομα	Έναρξη της μηχανής	Αυτοδιάγνωση
 σταθερή	Είναι η πρώτη εκκίνηση λειτουργίας της μηχανής και πρέπει να γεμίσετε το κύκλωμα νερού	Προχωρήστε σύμφωνα με τις υποδείξεις του κεφ. «3. ΑΡΧΙΚΗ ΛΕΙΤΟΥΡΓΙΑ ΤΗΣ ΣΥΣΚΕΥΗΣ»
 σταθερή (άσπρη) <ul style="list-style-type: none"> Λυχνία : δείχνει την επιλεγμένη θερμοκρασία του καφέ Λυχνία : δείχνει ότι η μηχανή είναι έτοιμη για την παροχή ζεστού νερού 	Η μηχανή είναι έτοιμη για την παροχή	Ετοιμάστε τη μηχανή και προχωρήστε στην παρασκευή του ροφήματος
 σταθερή	Η λειτουργία εξοικονόμησης ενέργειας είναι ενεργή	Ανατρέξτε στο κεφ. «7. ΜΕΝΟΥ ΡΥΘΜΙΣΕΙΣ» αν επιθυμείτε να απενεργοποιήσετε τη λειτουργία
 σταθερή	Το δοχείο κόκκων (A2) είναι άδειο	Γεμίστε το δοχείο των κόκκων
 αναβοσβήνει	Θέλετε να προχωρήσετε στην άλεση, αλλά το δοχείο κόκκων (A2) είναι άδειο	Γεμίστε το δοχείο των κόκκων
 αναβοσβήνει σύντομα ανά τακτά διαστήματα	Ο διακόπτης (B2) είναι γυρισμένος στη θέση μέγιστης ρύθμισης 	Εάν μετά την άλεση ο καφές μέσα στο φίλτρο δεν επαρκεί, επιλέξτε ένα νέο πεδίο άλεσης σύμφωνα με την περιγραφή στο κεφάλαιο «7. ΜΕΝΟΥ ΡΥΘΜΙΣΕΙΣ».
 σταθερή	Το νερό στο δοχείο (A14) δεν είναι αρκετό ή το δοχείο νερού δεν έχει τοποθετηθεί σωστά	Γεμίστε το δοχείο ή αφαιρέστε και τοποθετήστε ξανά και σωστά το δοχείο





ΛΥΧΝΙΕΣ	ΕΠΕΞΗΓΗΣΗ ΤΩΝ ΛΥΧΝΙΩΝ	ΕΝΕΡΓΕΙΑ
 αναβοσβήνει	Θέλετε να προχωρήσετε στην παρασκευή ενός ροφήματος, αλλά το δοχείο νερού (A14) είναι άδειο	Γεμίστε το δοχείο νερού
	Η άλεση είναι πολύ λεπτή και επομένως ο καφές βγαίνει πολύ αργά ή δεν βγαίνει καθόλου.	Αφαιρέστε το κύπελλο θήκης φίλτρου (C1), επαναλάβετε τις ενέργειες παρασκευής του καφέ λαμβάνοντας υπόψη τις υποδείξεις της παρ. «4.1 Στάδιο 1 - Άλεση (grinding)» και «4.2 Στάδιο 2 - Πίεση (tamping)»
	Το φίλτρο καφέ (C2) ή (C3) έχει βουλώσει	Ξεβγάλε τα φίλτρα με νερό βρύσης
	Το δοχείο (A14) δεν έχει τοποθετηθεί σωστά και οι αντίστοιχες βαλβίδες δεν έχουν ανοίξει	Πιέστε ελαφρώς το δοχείο έτσι ώστε να ανοίξουν οι βαλβίδες του
	Άλατα μέσα στο υδραυλικό κύκλωμα	Προχωρήστε σε αφαλάτωση όπως αναφέρει το κεφ. «11. ΑΦΑΛΑΤΩΣΗ»
 σταθερή	Η συσκευή είναι έτοιμη για την παροχή ατμού	Η συσκευή έχει φτάσει στην κατάλληλη θερμοκρασία για την παροχή ατμού. Για να προχωρήσετε στην παροχή, περιστρέψτε τον διακόπτη ατμού (A4)
 αναβοσβήνει	Η συσκευή είναι αναμμένη και η λειτουργία εξοικονόμησης ενέργειας είναι ενεργή: το κουμπί του ατμού (A4) είναι σε θέση για την παροχή ατμού	Το φως αναβοσβήνει για να δείξει ότι η συσκευή ετοιμάζεται να διανείμει ατμό: η διανομή ξεκινά μόλις η μονάδα είναι στη σωστή θερμοκρασία
	Η συσκευή είναι έτοιμη για την παροχή ατμού	Η συσκευή είναι σε κατάλληλη θερμοκρασία για την παροχή ατμού όταν η λυχνία παραμένει σταθερά αναμμένη
	Η συσκευή παρέχει ατμό	
 σταθερή	Το δοχείο για κόκκους δεν έχει τοποθετηθεί	Τοποθετήστε σωστά το δοχείο για κόκκους (A2) ή επιβεβαιώστε ότι έχει τοποθετηθεί σωστά. Το δοχείο τοποθετείται σωστά όταν το βέλος ▲ είναι ευθυγραμμισμένο με το σύμβολο ☐ και ακούγεται ένα «κλικ»
→		

ΛΥΧΝΙΕΣ	ΕΠΕΞΗΓΗΣΗ ΤΩΝ ΛΥΧΝΙΩΝ	ΕΝΕΡΓΕΙΑ
 αναβοσβήνει	<p>Η ρύθμιση του επιλογέα βαθμού άλεσης δεν είναι σωστή ή έχει ξεπεράσει τη μέγιστη δυνατή ρύθμιση</p>	<p>Τοποθετήστε τον επιλογέα σε μία από τις θέσεις άλεσης (μεταξύ 1 και 8) και θυμηθείτε:</p> <ul style="list-style-type: none"> • Να ρυθμίζετε την άλεση ενώ ο μύλος του καφέ βρίσκεται σε λειτουργία • Να ρυθμίζετε ένα επίπεδο τη φορά και να εκτελείτε τουλάχιστον 5 αλέσεις μεταξύ της μιας ρύθμισης και της άλλης
	<p>ΕΚΤΟΣ σω- στού εύρους corretto</p>  <p>Σωστό εύρος</p>	
 λειτουργία	<p>Η μηχανή χρειάζεται πίεση</p>	<p>Έχει μόλις ολοκληρωθεί η άλεση και η θήκη φίλτρου έχει συνδεθεί στο μύλο του καφέ</p>
	<p>Η θήκη φίλτρου έχει αποσυνδεθεί από τον μύλο του καφέ χωρίς πίεση</p>	<p>Αφαιρέστε το κύπελλο υποδοχής φίλτρου και προχωρήστε πιέζοντας τον καφέ όπως περιγράφεται στην παρ. «Η «τέλεια δόση»» «Εάν χρησιμοποιείται προαλεσμένος καφές:»</p>
	<p>Το κύπελλο υποδοχής φίλτρου έχει αποσυνδεθεί χωρίς να έχει ολοκληρωθεί η άλεση ή η πίεση του καφέ έγινε πολύ νωρίς</p>	<p>Επαναλάβετε την άλεση</p>
	<p>Το χωνί του καφέ του μύλου έχει μπουκώσει</p>	<p>Καθαρίστε όπως αναγράφεται στην παρ. «8.5 Καθαρισμός του «Smart tamping station»». Αν το πρόβλημα επιμένει, προσεγγίστε το χωνί ανοίγοντας το ειδικό πορτάκι και καθαρίστε το χρησιμοποιώντας το βουρτσάκι</p>
	<p>Οι μύλοι έχουν μπλοκάρει από κάποιο ξένο σώμα</p>	<p>Αφαιρέστε το ξένο σώμα και καθαρίστε τους μύλους σύμφωνα με τις οδηγίες στην παρ. «8.3 Καθαρισμός των μύλων».</p>
 σταθερή (κόκκινη)	<p>Θα πρέπει να προχωρήσετε σε καθαρισμό των αλάτων</p>	<p>Προχωρήστε σε αφαλάτωση σύμφωνα με τις υποδείξεις του κεφ. «11. ΑΦΑΛΑΤΩΣΗ»</p>
 αναβοσβήνει (κόκκινη) +  αναβοσβήνει (πορτοκαλί)	<p>Η μηχανή εκτελεί αφαλάτωση</p>	<p>Προχωρήστε ολοκληρώνοντας την διαδικασία όπως περιγράφεται στο κεφ. «11. ΑΦΑΛΑΤΩΣΗ»</p>
 αναβοσβήνει (κόκκινη) +  σταθερή (άσπρη)	<p>Είναι απαραίτητο να προχωρήσετε στο ξέβγαλμα</p>	



ΛΥΧΝΙΕΣ	ΕΠΕΞΗΓΗΣΗ ΤΩΝ ΛΥΧΝΙΩΝ	ΕΝΕΡΓΕΙΑ
 αναβοσβήνει (κόκκινη) +  αναβοσβήνει (άσπρη)	Η συσκευή εκτελεί το ξέβγαλμα του κύκλου αφαλάτωσης	
 σταθερή (πορτοκαλί)	Είναι απαραίτητο να προχωρήσετε στον καθαρισμό του ακροφυσίου καφέ	Δείτε παρ. «8.1 Καθαρισμός του ακροφυσίου καφέ»
 αναβοσβήνει (πορτοκαλί)	Η συσκευή εκτελεί τον καθαρισμό του ακροφυσίου καφέ	
Όλες οι λυχνίες αναβοσβήνουν	Γενικός συναγερμός	Απευθυνθείτε σε κέντρο τεχνικής υποστήριξης

13. ΑΝ ΚΑΤΙ ΔΕΝ ΛΕΙΤΟΥΡΓΕΙ

ΠΡΟΒΛΗΜΑ	ΑΙΤΙΑ	ΕΠΙΛΥΣΗ
Υπάρχει νερό μέσα στον δίσκο συλλογής σταγόνων (A10)	Οφείλεται σε φυσιολογική λειτουργία των εσωτερικών κυκλωμάτων της μηχανής	Αδειάζετε και πλένετε τακτικά τον δίσκο συλλογής σταγόνων
Δε βγαίνει πλέον ο καφές εσπρέσο	Έλλειψη νερού στο δοχείο (A14)	Γεμίστε το δοχείο
	Η λυχνία  (B6) ανάβει υποδεικνύοντας ότι το κύκλωμα του καφέ ή το κύκλωμα του ατμού είναι άδειο	Πατήστε το κουμπί που αντιστοιχεί στη λυχνία  για να γεμίσει το κύκλωμα
	Το φίλτρο (C2) ή (C3) είναι βουλωμένο	Ξεβγάλτε τα φίλτρα με νερό βρύσης
	Το δοχείο (A14) δεν έχει τοποθετηθεί σωστά και οι βαλβίδες στη βάση του δεν είναι ανοιχτές	Πιέστε ελαφρά το δοχείο έτσι ώστε να ανοίξει τις βαλβίδες στη βάση του
	Άλατα μέσα στο υδραυλικό κύκλωμα	Προχωρήστε σε αφαλάτωση όπως αναφέρει το κεφ. «11. ΑΦΑΛΑΤΩΣΗ»
Η θήκη του φίλτρου δεν στερεώνεται στη μηχανή	Πολύ λεπτή άλεση	Αφαιρέστε το κύπελλο θήκης φίλτρου (C1), επαναλάβετε τις ενέργειες παρασκευής του καφέ λαμβάνοντας υπόψη τις υποδείξεις της παρ. «4.1 Στάδιο 1 - Άλεση (grinding)» και «4.2 Στάδιο 2 - Πίεση (tamping)»
	Ο αλεσμένος καφές δεν έχει πατηθεί ή είναι σε υπερβολική ποσότητα	Επαναλάβετε την άλεση με διαφορετικές ρυθμίσεις. Μειώστε την ποσότητα της δόσης: επιβεβαιώστε ότι το φίλτρο (C2) ή (C3) (1 ή 2 φλιτζάνια) είναι σωστό σε σχέση με τη δόση της άλεσης (κουμπί 2x (B3) επιλεγμένο ή όχι)
		→

ΠΡΟΒΛΗΜΑ	ΑΙΤΙΑ	ΕΠΙΛΥΣΗ
Ο καφές espresso στάζει από το χείλος της θήκης του φίλτρου (C1) και όχι από τις οπές	Η θήκη φίλτρου δεν έχει τοποθετηθεί καλά	Στερεώστε σωστά τη θήκη φίλτρου και στρέψτε την μέχρι τέλους με δύναμη
	Το στεγανοποιητικό παρέμβυσμα του ακροφυσίου καφέ (A18) έχασε την ελαστικότητά του ή είναι βρώμικο	Αντικαταστήστε το στεγανοποιητικό παρέμβυσμα του ακροφυσίου καφέ σε ένα Κέντρο Υποστήριξης
	Το φίλτρο (C2) ή (C3) είναι βουλωμένο	Ξεβγάλε τα φίλτρα με νερό βρύσης
Ο αφρός του καφέ είναι ανοιχτόχρωμος (κατεβαίνει γρήγορα από το στόμιο)	Είναι απαραίτητο να ελέγξετε εκ νέου τις ρυθμίσεις της συσκευής	Αφαιρέστε το κύπελλο, επαναλάβετε τις διαδικασίες για να κάνετε τον καφέ λαμβάνοντας υπόψη τις υποδείξεις της παρ. «4.1 Στάδιο 1 - Άλεση (grinding)» και «4.2 Στάδιο 2 - Πίεση (tamping)»
Ο αφρός του καφέ είναι σκουρόχρωμος (ο καφές βγαίνει αργά από το στόμιο)	Είναι απαραίτητο να ελέγξετε εκ νέου τις ρυθμίσεις της συσκευής	Αφαιρέστε το κύπελλο θήκης φίλτρου (C1), επαναλάβετε τις ενέργειες παρασκευής του καφέ λαμβάνοντας υπόψη τις υποδείξεις της παρ. «4.1 Στάδιο 1 - Άλεση (grinding)» και «4.2 Στάδιο 2 - Πίεση (tamping)»
Στο τέλος της αφαλάτωσης, η συσκευή χρειάζεται κι άλλο ξέβγαλμα	Κατά τη διάρκεια του κύκλου ξεβγάλματος, το δοχείο έχει γεμίσει μέχρι στη στάθμη MAX	Επαναλάβετε το ξέβγαλμα (δείτε κεφ. «11. ΑΦΑΛΑΤΩΣΗ»)
Η συσκευή δεν αλέθει τον καφέ	Στο εσωτερικό του μύλου του καφέ υπάρχει κάποιο ξένο σώμα	Προχωρήστε στον καθαρισμό των μύλων όπως υποδεικνύεται στην παρ. «8.3 Καθαρισμός των μύλων», βεβαιωθείτε ότι έχετε αφαιρέσει όλους τους κόκκους από το δοχείο κόκκων (A2) πριν το αφαιρέσετε. Προτού επανατοποθετήσετε τον μύλο άλεσης, αναρροφήστε προσεκτικά τυχόν υπολείμματα από την υποδοχή του
	Το δοχείο για κόκκους (A2) δεν είναι σε σωστή θέση	Το δοχείο τοποθετείται σωστά όταν το βέλος ▲ είναι ευθυγραμμισμένο με το σύμβολο ☐ και ακούγεται ένα «κλικ»
→		

ΠΡΟΒΛΗΜΑ	ΑΙΤΙΑ	ΕΠΙΛΥΣΗ
<p>Αν εάν επιθυμείτε να αλλάξετε ποιότητα καφέ</p>	<p>θα πρέπει να αφαιρέσετε όλους τους κόκκους από τη μηχανή</p>	<ul style="list-style-type: none"> • Αδειάστε το δοχείο για κόκκους (A2) (εκτελώντας αλέσεις εν κενώ ή αναρροφώντας ενδοχομένως τα υπολείμματα των κόκκων). • Συνδέστε το κύπελλο του φίλτρου (C1) και αλέστε «εν κενώ» για να ελευθερωθεί ο αγωγός διέλευσης του καφέ: στη συνέχεια συνδέστε το κύπελλο του φίλτρου στην έξοδο του μύλου (A19) ευθυγραμμίζοντάς το με την ένδειξη INSERT και περιστρέψτε το προς τα δεξιά. Η άλεση ξεκινά όταν το κύπελλο φτάσει στη θέση CLOSE και διακόπεται αυτόματα. Επαναλάβετε έως ότου το φίλτρο αδειάσει. • Εισάγετε στο δοχείο (A2) τη νέα ποικιλία κόκκων καφέ • Αν κατά την άλεση δεν επιτυγχάνεται η «τέλεια δόση», προχωρήστε ακριβώς όπως στην πρώτη χρήση
<p>Μετά την άλεση, το φίλτρο του καφέ (C2) ή (C3) είναι άδειο</p> <p>Μετά την άλεση, η σκόνη του καφέ στο φίλτρο είναι πολύ μεγάλη</p>	<p>Το χωνί του καφέ του μύλου έχει μπουκώσει</p>	<p>Καθαρίστε όπως αναγράφεται στην παρ. «8.5 Καθαρισμός του «Smart tamping station»». Αν το πρόβλημα επιμένει, προσεγγίστε το χωνί ανοίγοντας το ειδικό πορτάκι (A21) και καθαρίστε το χρησιμοποιώντας το βουρτσάκι</p> <div data-bbox="768 895 995 1257" style="text-align: center;"> </div>
<p>→</p>		

ΠΡΟΒΛΗΜΑ	ΑΙΤΙΑ	ΕΠΙΛΥΣΗ
Μετά την άλεση, η σκόνη του καφέ στο φίλτρο (C2) ή (C3) δεν φτάνει για την «τέλεια δόση»	Το «Smart Tamping Station» χρειάζεται καθαρισμό	Καθαρίστε όπως αναγράφεται στην παρ. «8.5 Καθαρισμός του «Smart tamping station»», και έπειτα επαναλάβετε την άλεση
	Πρέπει να προσαρμόσετε την ποσότητα του αλεσμένου καφέ	Ρυθμίστε την ποσότητα με το ειδικό κουμπί (B2) ακολουθώντας τις ενδείξεις της παρ. «Η «τέλεια δόση»». Αν ο διακόπτης είναι ήδη στη θέση max, προχωρήστε σύμφωνα με τις οδηγίες στην ενότητα «7. ΜΕΝΟΥ ΡΥΘΜΙΣΕΙΣ» - «Εξτρα ρύθμιση της άλεσης»
	Με το χρόνο οι μύλοι φθείρονται	Προχωρήστε σε αντικατάσταση των μύλων άλεσης όπως υποδεικνύεται στην παρ. «8.4 Αντικατάσταση των μύλων άλεσης»

Før apparatet tas i bruk, les alltid heftet med sikkerhetsadvarsler.

1. BESKRIVELSE

1.1 Beskrivelse av apparatet - A

- A1. Lokk på bønnebeholder
- A2. Bønnebeholder
- A3. Koppebrett
- A4. Dampbryter
- A5. Varmtvannsutttak
- A6. Damprør
- A7. Rist til espresso-koppebrett
- A8. Rist til glass- eller muggebrett
- A9. Rist på dryppeskål
- A10. Dryppeskål
- A11. Vannivåindikator for dryppeskål
- A12. Lokk vannbeholder
- A13. Håndtak på vannbeholder
- A14. Vannbeholder
- A15. Holder for avherdingsfilter
- A16. Plass for koblingsstykke strømledning
- A17. Hovedbryter (ON/OFF)
- A18. Kaffeuttak
- A19. Utgang på kaffekvern (Tamping station)
- A20. Pressespak
- A21. Luke som gir tilgang til kaffeverntrakten

1.2 Beskrivelse av kontrollpanel - B

- B1. Bryter ON/Standby
- B2. Bryter for regulering av mengde kvernet kaffe
- B3. "X2"-tast: for bruk av 2-koppefilter
- B4. Kaffetemperaturtast
- B5. "OK"-tast: for å skille ut drikken / bekrefte valg
- B6. Tast for uttak av varmt vann
- B7. "My"-tast: brukes til egendefinering av drikkenes styrke
- B8. Funksjonsvalgryter
 - Espresso
 - Americano
 - Kaffe
 - Avkalking
- B9. Lampe "avkalking"
- B10. Lampe "damp klar"
- B11. Lampe "mangler kaffebønnebeholder"
- B12. Lampe "energisparing"
- B13. Lampe "Rengjøring" (se "8.1 Rengjøring av kaffeuttaket")
- B14. Lampe "bønnebeholder tom"
- B15. Lampe "mangler vann"
- B16. Lampe "pressing"
- B17. Manometer

1.3 Beskrivelse av tilbehør - C

- C1. Filterkopp
- C2. 1-koppefilter
- C3. 2-koppefilter
- C4. Reagensstrimmel "Total Hardness Test"
- C5. Avkalkingsmiddel
- C6. Forsyningskabel (avtakbar)
- C7. Spatel
- C8. Tilbehør for rengjøring av kaffeuttak
- C9. Softballs
- C10. Melkekanne
- C11. Rengjøringsnål for dampdyse

1.4 Rengjøringstilbehør medfølger ikke, anbefalt av produsenten

For ytterligere informasjon henvises det til Delonghi.com.



Rengjøringstablett

(Se "8.1 Rengjøring av kaffeuttaket")

 Rengjøringsmidler
EAN: 800439933307

2. KLARGJØRING AV APPARAT

Rengjør i lunkent vann og skånsomt vaskemiddel, og gjør deretter som følger:

1. Sett inn bønnebeholderen (A2) i kaffekvernen (fig. 1). Beholderen er korrekt satt på plass når pilen ▲ er på linje med symbolet ☐ og det kan høres et klikk (fig. 2).
2. Sett inn dryppeskålen (A10) komplett med koppebrett (A8) og dryppeskålrist (A9) (fig. 3).
3. Trekk ut vannbeholderen (A14) (fig. 4) og fyll den med ferskt og rent vann, og se til at nivåmerkingen med teksten MAX ikke overskrides (fig. 5).
4. Sett deretter inn beholderen igjen.

OB! *Apparatet må aldri startes opp uten beholder eller uten at det er vann i beholderen.*

NB! *Vi anbefaler at vannhardheten stilles inn ved å følge prosedyren i kapittel "7. Programmeringsmeny".*

3. FØRSTE GANGS OPPSTART AV APPARATET

1. Sett kontakten på strømledningen (C6) inn på baksiden av apparatet (A16) (fig. 6), og sett deretter støpset inn i stikkontakten. Se til at hovedbryteren (A17), som finnes bak på apparatet er trykket inn i posisjon I (fig. 7).
2. Sett en beholder med kapasitet på minst 100 ml under varmtvannsutttaket (samme som kaffeuttaket (A18)) (fig. 8).
3. Trykk på tasten (B6) ved siden av lampen ☐ (fig. 9): tilberedelsen vil starte og stoppe automatisk. Tøm beholderen.

Før man tar maskinen i bruk må de innvendige rørkretsene på maskinen skylles. Gjør som følger:

- Hekt filterkopp (C1) komplett med filter på maskinen. For en korrekt fasthektning, hold håndtaket til filterkopp på linje med symbolet INSERT (fig. 10), og drei deretter håndtaket mot høyre, til den står på høyde med posisjonen CLOSE.
- Sett en beholder under filterkopp og damputtaksrøret (A6).
- Trykk på OK-tasten (B5) (fig. 11) for å starte tilberedelsen.
- Når uttaket er ferdig vrir man på dampbryteren (A4) (fig. 12) og slipper ut damp noen sekunder slik at dampkretsen skylles. For et optimalt uttak anbefales det å gjenta denne operasjonen 3 eller 4 ganger. Dette vil gjøre det mulig å fjerne vannet i røret før det slippes ut damp.

Apparatet er nå klart til bruk.

NB! *Skyllingen av de innvendige kretsene burde utføres også når apparatet ikke har vært i bruk over en lengre periode.*

Første gang apparatet brukes må man tilberede 4-5 kaffedrikker før resultatet begynner å bli tilfredsstillende. Vær særlig oppmerksom på kaffemengden som kvernes i filteret ((C2) o (C3)) (se instruksjoner i paragrafen "4.1 Fase 1 - Maling (grinding)"). Gjør som vist i kapittel ""Perfekt dose"".

4. TILBEREDELSE AV KAFFE

4.1 Fase 1 - Maling (grinding)

- Hell bønner i beholderen (A2) (fig. 13). Det anbefales å kun bruke den mengden bønner som er nødvendig for tilberedelsen. På denne måten vil man alltid bruke fersk kaffe.
- Velg ønsket malegrad (fig. 14). Fabrikkinnstilling er 5 (middels malegrad). Hvis resultatet ikke er tilfredsstillende kan man regulere nivået i henhold til ens egen smak og kaffetypen (regulering må utføres mens kaffekvernen er i funksjon).

NB! *En malegrad på mellom 3 og 6 er anbefalt for de fleste kaffedrikker. Ved bruk av malegrad 1 eller 2 vil resultatet av oppmalingen vil bli svært finkornet, og dette er kun anbefalt for spesielle kaffetyper (lettbrønt kaffe).*

- Sett inn en av kaffefiltrene (C2) eller (C3) i filterholderen (C1) (fig. 15). Hvis det brukes filter for 2 kopper, trykker man på tasten 2X (B3). Med dette valget doubles også mengden espresso.
- Mengdebryteren (B2) reguleres med utgangspunkt i minste posisjon (fig. 16).

Det henvises til paragrafen "Reguler mengden malt kaffe i filteret." for ytterligere anvisninger.

- Hekt på filterholderen til utgangen på kaffekvernen (A19) og rett inn med teksten INSERT. Vri deretter filterkopp mot høyre. Kverningen starter når filterkopp når posisjonen CLOSE og avbrytes deretter automatisk.

Reguler mengden malt kaffe i filteret.

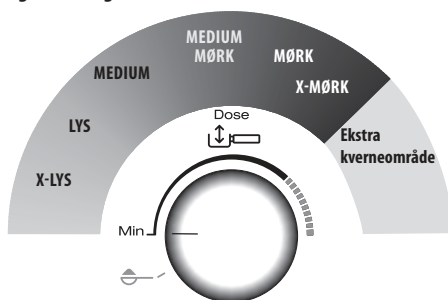

Hver type kaffebønne gir et forskjellig resultat når det males, og reguleringen vil derfor kreve stor presisjon i begynnelsen.

Denne illustrasjonen gir anvisninger om hvordan dosen reguleres, basert på brenningsgraden til kaffen. De må anses som et utgangspunkt, men kan variere avhengig av typen kaffebønner.

- Still inn dosen for minste posisjon.
- Man må basere seg på brenningsgraden til kaffen som brukes og vri langsomt på bryteren.

4.2 Fase 2 - Pressing (tamping)

- Etter at oppmalingen er ferdig må man senke pressespaken (A20) helt ned (ikke ta ut filterholderen) (fig. 17). Gjenta 2 ganger for et perfekt resultat.
- Hold pressespaken helt ned når filterholderen tas ut (fig. 18). Sett deretter spaken tilbake i startposisjon.
- Når man har kontrollert at kaffedosen er korrekt (se ""Perfekt dose""), kan man hekte filterholderen på kaffeuttaket (A18) (fig. 19).

NB! *Hvis det blir værende rester av kaffe langs bordet på filteret, vil ikke dette påvirke kvaliteten eller det endelige resultatet på noen måte.*

"Perfekt dose"

- Kaffefiltrene har et innvendig referansemærke som angir den perfekte dosen.

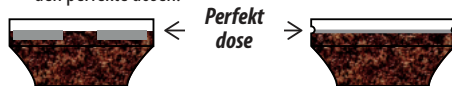

Lasermerket

Stempelmerket

- Lasermerket filter: Den perfekte dosen samsvarer med den øvre lasermerkede linjen.
- Stempelmerket filter: Den perfekte dosen samsvarer med den stempelmerkede linjen.
- Se til at kaffen befinner seg på nivå etter pressing. Det kan være nødvendig å regulere bryteren (B2) flere ganger før man oppnår en perfekt dose.
- Hvis den malte kaffen er for fin eller grov, men dosen befinner seg innenfor perfekt dose, kan man prøve å regulere

malegraden slik at den blir enten grovere eller finere (se "4.1 Fase 1 - Maling (grinding)"). Hvis kaffen er for finmalt (langsom flyt) må den gjøres grovere. Hvis kaffen er for grovmalt (hurtig flyt) må den gjøres finere.

- **Vår barista anbefaler:** Ta ut filterholderen mens presses-paken (A20) er senket for å oppnå en perfekt avslutning på kaffedosen.
- **Hvis det brukes forhåndsmalt kaffe:**
 - Hell forhåndsmalt kaffe i filteret.
 - Vri bryteren til .
 - Fest filterholderen til utgangen på kaffekvernen.
 - Senk pressespaken.













4.3 Fase 3 - Brygging (brewing)

1. Velg temperatur (fig. 20) (se "Temperatur for tilberedelse av kaffe").
2. Velg ønsket drikk (fig. 21).
3. Trykk på OK (B5) for å starte tilberedelsen (fig. 11) (forhånds-brygging og brygging). Tilberedelsen starter opp og avbrytes automatisk.

Temperatur for tilberedelse av kaffe

Vanntemperaturen er kontrollert under hele tilberedelsen for å garantere stabilitet i ekstraksjonsfasen. Specialista Prestigio tilbyr 3 bryggetemperaturer * som tilsvarer et temperaturområde på mellom 92°C og 96°C.

Det anbefales å tilpasse temperaturen til den enkelte kaffebøn-nens brenningsgrad. Robusta-bønner har behov for en lavere temperatur, mens Arabica-bønner har behov for en høyere temperatur. Det samme gjelder for bønner med en mørk brennings-grad eller for lettbrønte bønner.

Temperaturnivå	Tilknyttet lampe	Brenningsnivå
MIN	   	Mørk
MED	   	Medium mørk
MAX	   	Minimum medium

* Denne temperaturen viser til vannet i thermoblock. Denne avviker fra temperaturen til drikken i koppen eller temperaturen som måles når drikken kommer ut fra uttaket i filterholderen.

5. TILBEREDELSE AV MELKEDRIKK

5.1 Skumme melken

1. Hell mengden melk som ønskes å skummes ned i kannen (C10) og husk at melkevolumet vil øke 2-3 ganger (fig. 22). For et tykkere og mer homogent melkeskum anbefales det å bruke hel kumelk som holder kjøleskaptemperatur (cirka 5°C).

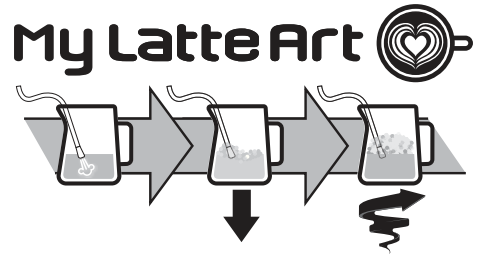

2. For å skumme melken holder man dampprøret (A6) på melkens overflate slik at luften blandet seg med melken og dampen.
3. Hold dampprøret på overflaten og vær særlig oppmerksom slik at det ikke kommer inn for mye luft som igjen kan skape store bobler.
4. Dypp dampprøret ned i melken slik at det skapes en virvel. Når ønsket temperatur er nådd lukker man igjen dampprøret og venter til damptilberedelsen avbrytes fullstendig før melkekannen tas ut av maskinen.

Vår barista anbefaler:

- **Fersk melk er å foretrekke.** Bruk alltid melk som holder kjøleskaptemperatur.
- For et bedre resultat anbefales det å oppbevare melkekannen i kjøleskap.
- Helmelk garanterer optimale resultater. Resultatet og skummets tekstur varierer avhengig av om det brukes kumelk eller vegetalske melketyper.
- Etter å ha skummet melken må man fjerne boblene ved å riste litt på melkekannen.

Rengjøring av damputtaket:

1. Etter hver bruk bør man fjerne melkerester fra damputtaket med en klut (fig. 23). For en mer nøyaktig rengjøring anbefales det å bruke Eco MultiClean. Dette sikrer god hygiene ved å fjerne protein og fett fra melken, og kan brukes til å rengjøre hele maskinen.
2. La det skilles ut damp noen sekunder slik at uttaket rengjøres (fig. 12).
3. Vent til uttaket kjøles ned. For å bevare uttakets effektivitet over tid burde det anvendes en rengjøringsnål (C11) til å frigjøre de 3 åpningene (fig. 24).







6. KAFFEMENGDEN KAN EGENDEFINERES VED Å TRYKKE PÅ TASTEN (my) (B7)

1. Klargjør maskinen slik at den tilbereder 1 eller 2 kopper av ønsket kaffedrikk. Fest deretter filterholderen (C1) komplett med filter (C2) eller (C3) og malt kaffe.
2. Vri på bryteren (B8) for å velge drikk som skal programmeres.
3. Trykk på tasten (my). Lampen i den aktuelle tasten (my) vil blinke.
4. Trykk på OK-tasten for å starte tilberedelsen. Lampene i OK-tastene og (my) blinker.
5. Når man har nådd ønsket mengde trykker man på OK. Hvis drikk har behov for flere ingredienser må man starte tilberedelsen av denne. Når ønsket mengde er nådd trykker man på OK.
6. Trykk på tasten (my) for å lagre. Apparatet er klart for ny bruk og lampen (my) forblir tent.

Hvis man ikke ønsker å lagre programmeringen trykker man på en hvilken som helst tast.

NB!

- Det er mulig å programmere kaffedrikker, men ikke uttak av damp og varmtvann.
- Programmeringen endrer mengden til drikkene, men ikke til den malte kaffen,
- Drikkene "X2" kan programmeres separat.
- **For å gå tilbake til standardverdier holder man inne tasten (my) inntil maskinen slår seg av. Den valgte drikk går tilbake til fabrikkinnstillinger.**

Kaffeoppskrift	Standardmengde	Programmert mengde
 Espresso	35 ml	fra 25 til 90 ml
 Espresso X2	70 ml	fra 50 til 180 ml
 Coffee	80 ml	fra 50 til 120 ml
 Coffee X2	160 ml	fra 120 til 240 ml
 Americano	120 ml	<ul style="list-style-type: none"> • Espresso: fra 25 til 60 ml • vann: fra 25 til 120 ml
 Americano X2	240 ml	<ul style="list-style-type: none"> • Espresso: fra 50 til 120 ml • vann: fra 50 til 240 ml



7. PROGRAMMERINGSMENY

1. Åpne menyen:

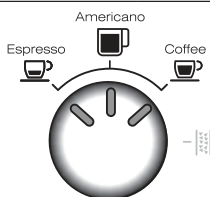

Hold inne samtidig i 5 sekunder x2 (my)

2. Innstillinger som velges fra bryter (B8)



Til knyttet innstilling	Vri til	Reguleringer
Ekstra regulering av kaffekvern	 Espresso	x2 → Område 1
		☰ → Område 2
Vannhardhet	 Americano	x2 → bløtt
		☰ → middels
		OK → hardt/svært hardt
Autostopp	 Coffee	x2 → 9 minutter
		☰ → 1,5 timer
		OK → 3 timer

3. Innstillinger som velges fra tast:

Energisparing	 → Aktiv
	 → Avslått
Fabrikkinnst.	Hold inne tasten (my) i 5 sekunder inntil lampen tennes og lyser uavbrutt.

4. Lagre de nye innstillingene ved å trykke på ON/Standby (B1)

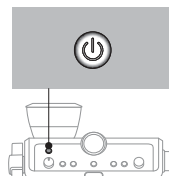











8. RENGJØRING AV APPARATET

OBS!

- Ved rengjøring av maskinen må man ikke bruke løsemidler, skuremidler eller sprit.
- Ikke bruk metallgjenstander til å skrape løs avleiringer eller kafferester, da dette kan lage riper i overflaten til deler av metall eller plast.
- For oppholdsperioder som overgår en uke, anbefales det å foreta en skyllesyklus før maskinen igjen tas i bruk.

Fare!



- Under rengjøringen må man ikke dyppe maskinen i vann. Det er et elektrisk apparat.
- Før man tar til med rengjøring av eksterne deler på apparatet, må man slå av maskinen og trekke ut støpset, slik at maskinen kan avvåles.

					
	×	✓	✓	×	×
	✓	×	×	✓	✓
	×	×	×	✓	✓
	×	×	×	✓	✓
	×	×	✓	✓	×
	×	×	×	✓	✓

8.1 Rengjøring av kaffeuttaket

Når lampen  tennes (oransje) (B13) må man gå videre til rengjøring av kafferørkretsen. For å foreta en rensesyklus må det anvendes tabletter for rengjøring av kaffemaskiner. For ytterligere informasjon bes man besøke www.Delonghi.com.



1. Sett inn 1-koppfilter (C2) i filterholderen (C1) (fig. 25).
2. Sett inn renseskoppen i filteret (C8) (fig. 25) og trykk den helt inn.
3. Legg tablettene i renseskoppen (fig. 26).
4. Fest filterholderen til kaffeuttaket (A18).
5. Fyll opp vannbeholderen (A14). Se til at dryppeskålen (A10) er tom.

6. Hold inne tasten  (B6) inntil lampen  (B13) tennes. Etter noen minutter vil rengjøringen avbrytes automatisk.
7. Fjern filterholderen og renseskoppen.
8. Skyll filterholderen og filteret i rennende vann.
9. Sett tilbake filterholderen og foreta deretter en skylning med tasten . Det anbefales å sette en beholder under filterholderen.
10. Fjern og tøm ut dryppeskålen.

NB!

Denne rengjøringssyklusen kan startes når som helst ved å trykke på tasten  i noen sekunder. For å avbryte operasjonen kan man holde inne knappen i 10 sekunder.

8.2 Rengjør rundt posisjonen til bønnebeholderen

1. Se til at bønnebeholderen (A2) er tom. Foreta eventuelt noen malingssykluser uten bønner for å tømme den.
2. Hekt av beholderen ved å vri den mot klokkeretningen og ta den ut av maskinen (fig. 27)
3. Sug opp alle kafferester (fig. 28).
4. Rengjør med en fuktig klut rundt bønnebeholderen og tørk av (fig. 29).
5. Sett beholderen tilbake i kaffekvernen. Beholderen er korrekt satt på plass når pilen  er på linje med symbolet  og det høres et klikk (fig.30).

8.3 Rengjøring av kvernene

Når bønnebeholderen (A2) rengjøres må man huske å rengjøre rundt beholderen og kaffekvernen med en fuktig klut. Man bes henvende seg til et servicesenter for fjerning og bytting av kvernene.

Kvernen kan tas ut hvis den er blokkert av et fremmedlegeme. Hvis dette skulle inntreffe må man fjerne bønnebeholderen og gjøre følgende:

1. Fest filterholderen (C1) og foreta en tom kvernesyklus for å frigjøre kaffekretsen.
2. Slå av apparatet.
3. Vri kaffekvernregulatoren helt rundt mot klokkeretningen, helt til den kommer i posisjon "REMOVE" (fig. 31).
4. Trekk ut den øvre delen av kvernen ved å ta tak i det anviste håndtaket (fig.32).
5. Rengjør kvernen med en børste (fig. 33) og fjern alle kafferester med en støvsuger (fig. 28).

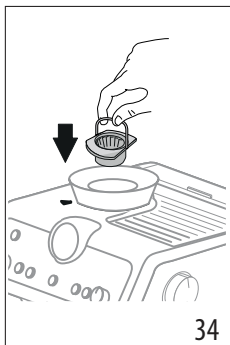
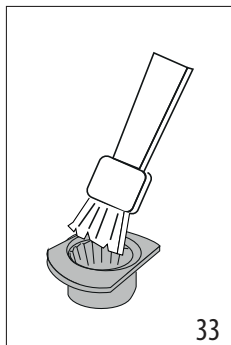

6. Sett kvernen på plass (fig. 34).
7. Vri regulatoren for å velge ønsket malegrad (fig. 14). Kontroller at kvernen er godt satt inn ved å dra i håndtaket. Kvernen er korrekt satt inn hvis den ikke beveger seg.

8.4 Bytte av kverner

Når den oppkvervede kaffemengden reduseres ytterligere bes man henvende seg til et servicesenter for å bytte ut kvernene. Etterpå må man regulere kaffekvernen ved å gå til innstillingsmenyen ("7. Programmeringsmeny") og velge første reguleringsområde. Vri deretter mengdereguleringsbryteren (B2) til posisjon MIN og regulerer dosen som ved første gangs bruk (se "Perfekt dose").

8.5 Rengjøring av "Smart tamping station"

1. Rengjør sonen rundt holderen med en pensel eller børste (fig. 35).
2. Dra spaken (A20) helt ut og rengjør pressen med en kost (fig. 36). Slipp deretter opp spaken.
3. Bruk den lille børsten (C7) til å rengjøre kaffetrakten (fig. 37).

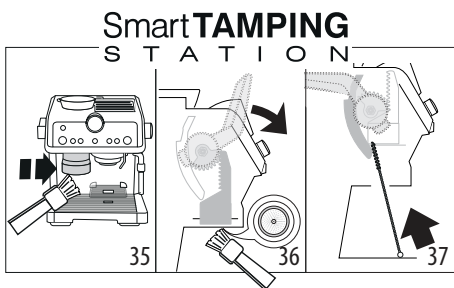

9. VANNHARDHET

Avkalkingslampen (B9) vil vises etter et forhåndsbestemt bruksintervall som avhenger av vannets hardhetsgrad. Det er mulig å programmere maskinen etter hvor hardt vannet man

braker faktisk er, og på denne måten endrer man frekvensen for hvor hyppig denne meldingen vises.

1. Ta den medfølgende teststrimmelen "TOTAL HARDNESS TEST" ut av forpakningen (C4).
2. Dypp strimmelen helt ned i et glass med vann i ca. et sekund.
3. Ta strimmelen ut av vannet og rist lett på den. Still inn apparatet som vist i kapittel "7. Programmeringsmeny".

Resultat vannhardhetstest	Tast	Nivå
	×2	1 bløtt vann
	≡ ⁸	2 middels hardt vann
	OK	3 hardt eller svært hardt vann

4. Still inn apparatet som vist i kapittel "7. Programmeringsmeny".

10. HVORDAN BRUKE SOFTBALLS

Softballs (C9) er et innovativt system som forlenger maskinens levetid uten at det påvirker vannkvaliteten, noe som gir en kaffe som er kremete og aromatisk. For en bedre ytelse anbefales det å legge Softballs i bløtt gjennom natten før de skal brukes.

1. Ta ut pakken med Softballs fra emballasjen (fig. 38).

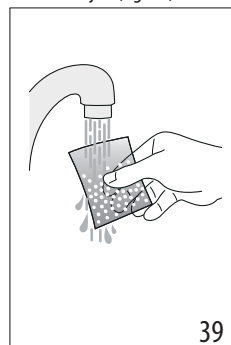
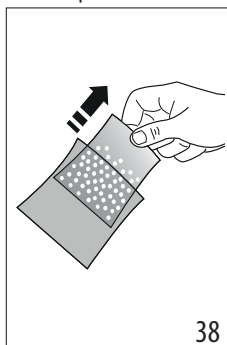

2. Skyll pakken med Softballs rennende vann (fig. 39).
3. Legg posen ned i vannbeholderen (A14) (fig. 40).

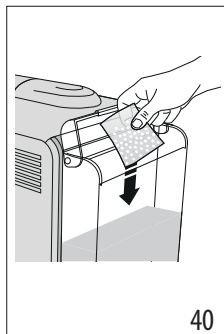

4. Skift ut pakken med Softballs hver 3. måned (fig. 41).

11. AVKALKING

OBS!

- Før bruk må man lese instruksjonene og merkingen som mer oppgitt på pakken med avkalkningsmiddel (C5).
- Det anbefales å bruke avkalkningsmiddel utelukkende produsert av De'Longhi. Hvis det anvendes upassende avkalkningsmidler, eller hvis avkalkningen utføres feil, kan dette føre til skader som ikke dekkes av produsentens garanti.
- Avkalkningsmiddelet kan skade ømfintlige overflater. Hvis produktet velter ved et uhell må man tørke opp umiddelbart.

For å utføre avkalkning	
Avkalkningsmiddel	De'Longhi avkalkningsmiddel
Beholder	Kapasitet 2 liter
Tid	~40min

1. (TA UT VANNAVHERDERFILTER OG SOFTBALLS HVIS NØDVENDIG). Hell avkalkningsmiddel i vannbeholderen (A14) opp til nivå **A** (tilsvarende en pakke på 100ml) avmerket på innsiden av tanken (fig. 42).

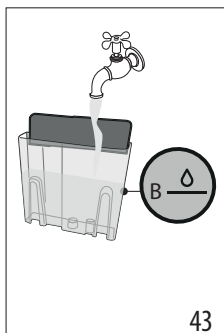
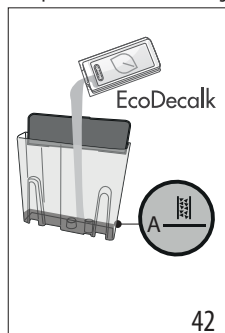

2. Tilsett vann inntil man når nivået **B** (fig. 43). Sett deretter beholderen inn i maskinen igjen.

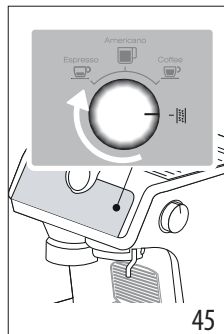
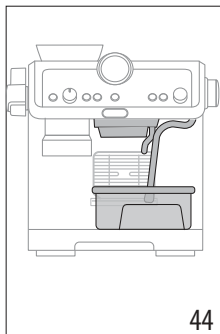

3. Se til at filterholderen (C1) ikke er satt inn og sett deretter en beholder under kaffeuttaket og damputtaket (A6) (fig. 44).
4. Vri bryteren (B8) til (fig. 45). Lampen OK vil tennes og lyse oransje. Lampen blinker.
5. Trykk på tasten OK: Lampen OK blinker.
6. Avkalkningsprogrammet starter opp og avkalkningsmiddel kommer ut fra uttakene. Avkalkningsprogrammet utfører automatisk en serie skyllesykluser for å fjerne restene av kalk som finnes seg inne i kaffemaskinen inntil beholderen er helt tom. Tilberedelsen avbrytes og lampen OK lyser hvitt. Det er nå nødvendig å foreta en skyllesyklus.
7. Tøm ut den anvendte beholderen og sett den deretter under uttakene.
8. Trekk ut vannbeholderen, tøm den for eventuelle rester etter avkalkningsmiddel, skyll den med vann, og fyll den deretter med friskt vann opp til MAX-nivå (fig. 46). Sett inn beholderen i holderen igjen.

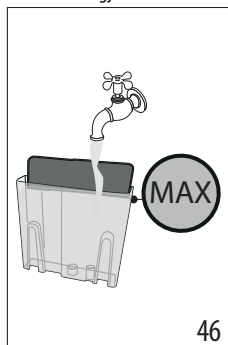

9. Trykk på tasten OK for å starte skyllingen.
10. Når skyllingen er ferdig vil tilberedelsen avbrytes og apparatet er klart til bruk.
11. Tøm beholderen som ble brukt til å samle opp skyllevann.











12. Ta ut og tøm dryppeskålen, og sett den deretter tilbake i apparatet.
13. Trekk ut og fyll beholderen med friskt vann før den settes inn igjen.

Apparatet er nå klart til bruk.





NB!

- Avkalkingszyklusen kan startes når som helst (selv om den tilhørende lampen ennå ikke er tent).
- Hvis avkalkingen er blitt startet opp ved et uhell må man holde inne OK-tasten i 10 sekunder. Skyllszyklusen kan ikke avbrytes.







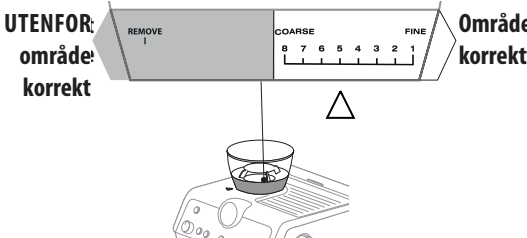
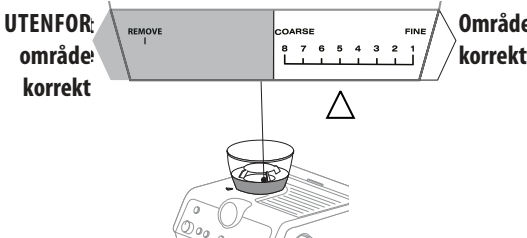



12. BESKRIVELSE AV KONTROLLAMPER

VARSELLAMPER	BESKRIVELSE AV KONTROLLAMPENE	OPERASJON
Alle lampene blinker kort	Slå på apparatet	Selvdiagnose
 fast lysende	Det er første gang maskinen slås på, og man må la vannkretsene i maskinen fylle seg opp	Man må gjøre som vist i kap. "3. Første gangs oppstart av apparatet"
 lyser uavbrutt (oransje) <ul style="list-style-type: none"> • Lampen : Viser den valgte kaffetemperaturen • Lampen : Viser at maskinen er klar til å skille ut varmt vann 	Apparatet er klart til bruk	Gjør klar maskinen og ta til med tilberedelse av drikken
 fast lysende	Funksjonen Energisparing er ikke aktiv.	Det henvises til kap. "7. Programmeringsmeny" hvis man ønsker å deaktivere funksjonen
 fast lysende	Kaffebønnebeholderen (A2) er tom	Fyll kaffebønnebeholderen
 blinkende	Man ønsker å male opp kaffe, men bønnebeholderen (A2) er tom	Fyll kaffebønnebeholderen
 blinker kort ved regelmessige intervaller	Bryteren (B2) er vridd til maksimal reguleringsposisjon 	Hvis kaffemengden etter malingen ikke er tilstrekkelig må det velges et annet malingsnivå som vist i kapittel "7. Programmeringsmeny".
 Lyser uavbrutt	Det er ikke nok vann i beholderen (A14), eller vannbeholderen er ikke korrekt satt i	Fyll beholderen eller trekk ut og sett inn igjen beholderen





VARSELLAMPER	BESKRIVELSE AV KONTROLLAMPENE	OPERASJON
 blinkende	Hvis man ønsker å tilberede en drikk, men bønnebeholderen (A14) er tom.	Fyll opp vannbeholderen
	Kaffen er for finmalt og renner ut for langsomt eller ikke i det hele tatt.	Trekk ut filterkoppene (C1) og gjenta operasjonen for å tilberede kaffe i samsvar med det som er oppgitt i par. "4.1 Fase 1 - Maling (grinding)" og "4.2 Fase 2 - Pressing (tamping)"
	Kaffefilteret (C2) eller (C3) er tilstoppet	Skyll filterene i rennende vann
	Beholderen (A14) er satt inn feil og ventilene nederst er ikke åpne	Press beholderen forsiktig inn slik at ventilene åpner seg
	Kalk innvendig i den hydrauliske kretsene	Utfør avkalking slik som vist i kap. "11. Avkalking"
 fast lysende	Apparatet er klart for å skille ut damp	Apparatet har nådd temperaturen for å skille ut damp. For å gå videre til uttaket vrir man på dampbryteren (A4)
 blinkende	Apparatet er påslått og funksjonen Energisparing er aktivert. Dampbryteren (A4) står i posisjon for å skille ut damp.	Lampen blinker for å vise at apparatet er klart for å skille ut damp. Uttaket starter med en gang apparatet har korrekt temperatur.
	Apparatet er klart for å skille ut damp	Apparatet har nådd temperaturen for å skille ut damp når lampen lyser uavbrutt
	Apparatet skiller ut damp	
 fast lysende	Kaffebønnebeholderen er ikke satt i	Sett inn bønnebeholderen (A2) eller kontroller at den er korrekt satt inn. Beholderen er korrekt satt på plass når pilen ▲ er på linje med symbolet ☐ og det høres et klikk
 blinkende	Regulering av bryteren for malegrad er ikke korrekt eller den overskrider maksimalt tilgjengelig nivå	Sett velgeren i en av maleposisjonene (mellom 1 og 8) og husk følgende: <ul style="list-style-type: none"> Regulering av malegrad må skje mens kaffekvernene er i funksjon Kvernen må reguleres ett nivå av gangen, og det må foretas minst fem male-sykler mellom hver regulering.
	UTENFOR område korrekt 	Område korrekt 



VARSELLAMPER	BESKRIVELSE AV KONTROLLAMPENE	OPERASJON
 fast lysende	Apparatet er avhengig av at kaffen presses sammen	Kverning er blitt utført og filterholderen er festet til kvernen.
	Filterholderen er løsnet fra kvernen uten at pressing er utført	Løsne filterholderen og press sammen kaffen som forklart i par. "Perfekt dose" "Hvis det brukes forhåndsmalt kaffe:"
	Filterholderen er blitt frakoblet uten at malingen er blitt fullført, eller pressingen er blitt gjort for tidlig	Gjenta kverningen
	Kaffetrakten i kvernen er tilstoppet.	Maskinen må rengjøres som forklart i par. "8.5 Rengjøring av "Smart tamping station". Hvis problemet vedvarer må man få tilgang til trakten ved å åpne den anviste luken og deretter løse den med spatelen
	Kvernen er blokkert av et fremmedlegeme	Fjern fremmedlegemet og rengjør kvernen som forklart i par. "8.3 Rengjøring av kvernene".
 Lyser (rød)	Det må utføres avkalking	Utfør avkalking som illustrert i kap. "11. Avkalking"
 blinker (rødt) +  blinker (oransje)	Apparatet utfører avkalking	Fullført operasjonen som forklart i kap. "11. Avkalking"
 blinker (rødt) +  Lyser (hvitt)	Det må utføres skylling	
 blinker (rødt) +  blinker (hvitt)	Apparatet utfører skyllingen som er del av avkalkingssyklusen	
 Lyser (oransje)	Det er nødvendig å foreta rengjøring av kaffeuttaket	Se par. "8.1 Rengjøring av kaffeuttaket"
 Blinker (oransje)	Apparatet utfører rengjøring av kaffeuttaket	
Alle lampene blinker	Generell alarm	Man bes henvende seg til De'Longhi servicesenter

13. HVIS NOE IKKE FUNGERER

PROBLEM	ÅRSAK	LØSNING
Det er vann i dryppeskålen (A10)	Dette er en normal del av funksjonen til maskinens innvendige kretser	Tøm og rengjør dryppeskålen regelmessig
		→

PROBLEM	ÅRSAK	LØSNING
Det skilles ikke ut espresso	Mangler vann i beholderen (A14)	Fyll beholderen
	Lampen  (B6) lyser for å vise at kaffekretsen og dampkretsen er tom	Trykk på tasten ved lampen  for å fylle kretsen
	Filteret (C2) eller (C3) er tilstoppet	Skyll filtrene i rennende vann
	Beholderen (A14) er ikke satt inn korrekt og ventilene nederst er ikke åpne	Press beholderen inn slik at ventilene åpner seg
	Kalk innvendig i den hydrauliske kretsene	Utfør avkalking slik som vist i kap. "11. Avkalking"
	For finmalt	Trekk ut filterkoppene (C1) og gjenta operasjonen for å tilberede kaffe i samsvar med det som er oppgitt i par. "4.1 Fase 1 - Maling (grinding)" og "4.2 Fase 2 - Pressing (tamping)"
Filterholderen fester seg ikke til apparatet	Den malte kaffen er ikke blitt presset, eller det er for mye malt kaffe	Gjenta malingen med andre innstillinger. Reduser dosemengden. Kontroller at filteret (C2) eller (C3) (1 eller 2 kopper) er blitt korrekt satt inn for den aktuelle dosen (tast 2x (B3) valgt eller ikke)
Det drypper espresso over kanten på filterholderen (C1) men ikke fra åpningene	Filterholderen er ikke satt inn korrekt	Sett på filterholderen på riktig måte og vri den helt inn
	Pakningen på kaffeuttaket (A18) er blitt elastisk eller er skittent	Skift ut pakningen i kaffeuttaket hos et Servisecenter
	Filteret (C2) eller (C3) er tilstoppet	Skyll filtrene i rennende vann
Kaffekremem er klar i fargen (renner hurtig fra tuten)	Man må gå over innstillingene til apparatet	Trekk ut filterkoppene, gjenta operasjonen for å tilberede kaffe som er gjengitt i par. "4.1 Fase 1 - Maling (grinding)" og "4.2 Fase 2 - Pressing (tamping)"
Kaffekremem er mørk i fargen (renner langsomt fra tuten)	Man må gå over innstillingene til apparatet	Trekk ut filterkoppene (C1) og gjenta operasjonen for å tilberede kaffe i samsvar med det som er oppgitt i par. "4.1 Fase 1 - Maling (grinding)" og "4.2 Fase 2 - Pressing (tamping)"
Når avkalkningen er blitt utført vil apparatet ha behov for en ekstra skyllesyklus	Under denne skyllesyklusen er ikke beholderen fylt opp til MAX-nivå	Gjenta skylling (se kap. "11. Avkalking")
→		

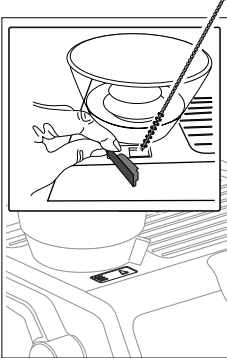
PROBLEM	ÅRSAK	LØSNING
Apparatet maler ikke opp ikke kaffe	Det finnes fremmedlegemer inne i kaffekvernen	Kvernene må rengjøres som forklart i par. "8.3 Rengjøring av kvernene", men påse at alle bønner er fjernet fra kaffebønnebeholderen (A2) før den tas ut. Før kvernen settes tilbake på plass må man suge opp alle urenheter rundt denne
	Bønnebeholderen (A2) befinner seg ikke i korrekt posisjon	Beholderen er korrekt satt på plass når pilen ▲ er på linje med symbolet ☒ og det høres et klikk
Hvis man ønsker kan kaffetypen byttes.	Man må fjerne alle kaffebønner i maskinen.	<ul style="list-style-type: none"> • Tøm kaffebønnebeholderen (A2) (kvern opp gjenværende innhold eller bruk en støvsuger til å tømme den). • Hekt på filterkoppene (C1) og foreta en kverning på tomgang for å rense opp kaffekretsen: Hekt filterholderen på utgangen til kaffekvernen (A19) og rett inn med teksten INSERT. Vri deretter filterkoppene mot høyre. Kverningen starter når filterkoppene når posisjonen CLOSE og avbrytes deretter automatisk. Gjenta inntil filteret er tomt • Tilsett en nye type kaffebønner i beholderen (A2) • Hvis malegraden ikke når "perfekt dose" gjør man som forklart for første gangs bruk
Etter maling er kaffefiltrene (C2) eller (C3) tomme	Kaffetrakten i kvernen er tilstoppet.	Maskinen må rengjøres som forklart i par. "8.5 Rengjøring av "Smart tamping station". Hvis problemet vedvarer må man få tilgang til trakten ved å åpne den anviste luen (A21) og deretter løsne den med spatelen
Etter kverningen er kaffefilteret fullt av kaffepulver		
→		

PROBLEM	ÅRSAK	LØSNING
Etter kverningen når ikke kaffepulveret i filterene (C2) eller (C3) "perfekt dose"	"Smart Tamping Station" har behov for rengjøring	Maskinen må rengjøres som forklart i par. "8.5 Rengjøring av "Smart tamping station" før man gjentar kverningen
	Mengden kvernet kaffe må reguleres	Foreta regulering med den anviste betjeningsbryteren (B2) og følg anvisningene i par. " "Perfekt dose" ". Hvis bryteren allerede er i max-posisjon gjør man som forklart i delen "7. Programmeringsmeny" - "Ekstra regulering av kaffekvern"
	Med tiden vil kvernene slites ned	Skift ut disse kvernene som forklart i par. "8.4 Bytte av kverner"

Innan du använder apparaten, läs alltid broschyren med säkerhetsvarningarna.

1. BESKRIVNING

1.1 Beskrivning av apparaten - A

- A1. Lock för behållaren för kaffeböner
- A2. Behållare för kaffeböner
- A3. Koppbricka
- A4. Ångknapp
- A5. Varmvattendispenser
- A6. Ångrör
- A7. Galler koppbricka för espresso
- A8. Galler koppbricka för glas eller mugg
- A9. Droppkarets galler
- A10. Droppbricka
- A11. Vattennivåvisare för droppkaret
- A12. Lock vattentank
- A13. Handtag för utdragning av vattenbehållaren
- A14. Vattenbehållare
- A15. Utrymmer för avhärdningsfilter
- A16. Utrymme för matningskabelns kontakt
- A17. Huvudströmbrytare (PÅ/AV)
- A18. Kaffedispenser
- A19. Utgång kaffekvarn (Tamping station)
- A20. Spak press
- A21. Lucka för att komma åt kaffekvarnens glidbana

1.2 Beskrivning av manöverpanelen - B

- B1. Knapp PÅ/Standby
- B2. Vred för justering av mängd malet kaffe
- B3. Knapp "X2": för att använda filtret för 2 kaffe
- B4. Knapp "kaffetemperatur"
- B5. Knapp "OK": för att dispensera dryck/för att bekräfta
- B6. Knapp "dispensering av varmt vatten"
- B7. Knapp "My": för att personalisera mängden av dryck
- B8. Valratt funktioner
 - Espresso
 - Americano
 - Coffee
 - Avkalkning
- B9. Varningslampa för "avkalkning"
- B10. Varningslampa "klar ånga"
- B11. Varningslampa "behållare för kaffeböner saknas"
- B12. Varningslampa "energibesparing"
- B13. Varningslampa "Rengöring" (se "8.1 Rengöring av kaffedispensern")
- B14. Varningslampa "behållare kaffeböner tom"
- B15. Varningslampa "vatten saknas"
- B16. Varningslampa pressning
- B17. Manometer

1.3 Beskrivning av tillbehören - C

- C1. Filterhållare
- C2. Filter 1 kopp
- C3. Filter 2 koppar
- C4. Reaktionssticka "Total Hardness Test"
- C5. Avkalkningsmedel
- C6. Strömkabel borttagbar
- C7. Borste
- C8. Tillbehör rengöring av kaffedispenser
- C9. Softballs
- C10. Mjölk kanna
- C11. Rengöringsnål för ångrör

1.4 Rengöringstillbehör ingår inte, rekommenderas av tillverkaren

För ytterligare informationer, besök Delonghi.com.



Rengöringspastiller

(Se "8.1 Rengöring av kaffedispensern")



Rengöringsmedel

EAN: 8004399333307

2. FÖRBEREDELSE AV APPARATEN

Diska samtliga tillbehör, med ljummet vatten och diskmedel för tallrikar och fortsätt sedan så här:

1. För in behållaren för kaffeböner (A2) i kaffekvarnen (fig. 1). Behållaren är korrekt införd när pilen ▲ är inriktad med symbolen  och du hör ett "klick" (fig. 2).
2. För in droppkaret (A10) komplett med koppbrickans galler (A8) och droppkarets galler (A9) (fig. 3);
3. Dra ur vattentanken (A14) (fig. 4) och fyll med färskt och rent vatten, se till att texten MAX inte övertäcks (fig. 5).
4. För sedan in tanken.

Observera: Sätt aldrig apparaten i drift utan vatten i behållaren eller om behållare saknas.

Observera: Vi rekommenderar dig att snarast anpassa vattnets hårdhet enligt proceduren som beskrivs i kapitel "7. Inställningsmeny".

3. FÖRSTA IBRUKTAGANDET AV MASKINEN

1. Sätt i kontakten till elsladden (C6) i avsett säte (A16) på baksidan av apparaten (fig. 6); och sätt sedan i stickkontakten i eluttaget. Försäkra dig att huvudströmbrytaren (A17), på apparatens baksida är intryckt i läge I (fig. 7);
2. Placera en behållare med minimum kapacitet på 100 ml, under dispensern för varmt vatten (i höjd med kaffedispensern (A18)) (fig. 8);
3. Tryck in knappen (B6) i höjd med indikationslampan  (fig. 9): dispenseringen startar och avbryts automatiskt. Töm behållaren.

Innan du börjar använda maskinen, är det nödvändigt att skölja maskinens interna kretsar. Utför följande:

- Haka fast filterhållarenheten (C1) komplett med filter vid maskinen: för korrekt fasthakning, rikta in handtaget på filterhållaren med "INSERT" (fig. 10) och vrid greppet mot höger, tills det är inriktat med läget "CLOSE";
- Placera en behållare under filterkoppens och ångröret (A6);
- Tryck in knappen OK (B5) (fig. 11): dispenseringen startar;
- Vid avslutad dispensering, vrid ångvredet (A4) (fig. 12) och dispensera ånga i några sekunder för att skölja ångkretsen: för en optimal dispensering, rekommenderas det att upprepa denna procedur 3 eller 4 gånger. Detta tillåter att eliminera vattnet i röret före dispensering av ånga.

Maskinen är nu klar för användning.

Observera: sköljningen av de interna kretsarna rekommenderas även om apparaten inte används under en längre tid.

Vid den första användningen är det nödvändigt att bereda 4-5 kaffe innan maskinen börjar ge ett tillfredsställande resultat: var särskilt uppmärksam på mängden malet kaffe i filtret ((C2) eller (C3)) (se instruktionerna i avsnitt "4.1 Fas 1 - Malning (grinding)").

Fortsätt enligt beskrivningen i kapitel "Den "perfekta dosen"".

4. BEREDNING AV KAFFE

4.1 Fas 1 - Malning (grinding)

- Häll bönorna i behållaren (A2) (fig. 13). Det rekommenderas att hälla i endast bönorna som krävs för beredningen: på detta sättet använder du alltid färskt kaffe;
- Välj malningsgrad (fig. 14). Fabriksinställningen är 5 (medium malning). Om resultatet inte är tillfredsställande, justera malningsgraden beroende på personlig smak och typen av kaffe (justeringen ska utföras när kaffekvarnen är igång).

Observera: Malningsgraden mellan 3 och 6 rekommenderas för de flesta typerna av kaffe. Resultatet av malningen med val på 1 eller 2 är mycket fin, att använda endast med mycket speciellt kaffe (lättrostat).

- För in ett av kaffefiltren (C2) eller (C3) i filterhållaren (C1) (fig. 15). Om du använder filtret för 2 koppar, tryck in knappen 2X (B3): med detta val fördubblas även mängden dispenserad espresso.
- Justera vredet för mängden (B2) med utgång från minimumläget (fig. 16).

Se avsnittet "Justera dosen malet kaffe i filtret" för ytterligare indikationer.

- Haka fast filterhållaren vid kaffekvarnens utgång (A19) och rikta in den med texten INSERT: vrid sedan filterkoppens åt höger. Malningen startar när filterhållaren når läget CLOSE och avbryts automatiskt.

Justera dosen malet kaffe i filtret

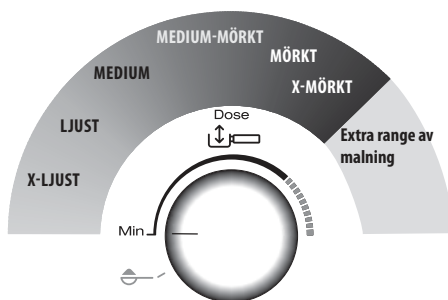

Varje typ av bönor ger ett annorlunda resultat vid malningen och därför kräver justeringen av dosen i början av malningen stor omsorg.

Denna illustration ger indikationer om hur man justerar dosen, på grundval av färgen på rostningen: de ska anses vara en utgångspunkt men kan skifta beroende på sammansättningen av kaffebönorna.

- Ställ in dosen på minimumläge.
- Med referens till rostningsfärgen på ditt kaffe, vrid vredet långsamt.

4.2 Fas 2 - Pressning (tamping)

- Efter malningen, sänk pressspaken (A20) till gränsläget (avlägsna inte filterhållaren) (fig. 17). För ett perfekt resultat, upprepa 2 gånger.
- Håll spaken nedtryckt till gränsläget under avlägsnandet av filterhållaren (fig. 18). För sedan tillbaka spaken till utgångsläget.
- När du kontrollerat att kaffedosen är korrekt (se "Den "perfekta dosen""), haka fast filterhållaren på kaffedispensern (A18) (fig. 19).

Observera: Om efter pressningen, kaffe finns kvar längs filtrets kanter, påverkar detta absolut inte kvaliteten av extraktionen och således slutresultatet.

Den "perfekta dosen"

- Kaffefiltren har en invändig referens för att identifiera den perfekta dosen.



- Filter med lasermärkning: den perfekta dosen motsvarar märkningens övre linje;
- Filter med upphöjd märkning: den perfekta dosen motsvarar den upphöjda linjen;
- Försäkra dig att kaffet är vid nivå efter pressningen. Set kan vara nödvändigt att justera vredet (B2) flera gånger innan du uppnår den perfekta dosen.

- Om kaffet är över- eller underutvunnet och den interna dosen är perfekt, justera malningsgraden till mera finmalt eller grovmalet (se "4.1 Fas 1 - Malning (grinding)"). Om kaffet är överutvunnet (alltför långsam dispensering), måste malningsgraden vara grövre. Om kaffet är underutvunnet (alltför snabb dispensering) måste malningsgraden vara finare.
- **Bartendern rekommenderar:** Ta ut filterhållaren medan presspaken (A20) är nedsänkt för att erhålla en perfekt finish av kaffedosen.
- **Om du använder förmalet kaffe:**
 - håll det förmalna kaffet i filtret;
 - vrid vredet på ;
 - haka fast filterhållaren vid kaffekvarnens utgång;
 - sänk presspaken.













4.3 Fas 3 - Dispensering (brewing)

1. Välj temperaturen (fig. 20) (se "Temperaturen för beredning av kaffe").
2. Välj önskad dryck (fig. 21).
3. Tryck in OK (B5) för att starta dispenseringen (fig. 11) (för-bryggnig och bryggnig). Kaffedispenseringen avbryts automatiskt.

Temperaturen för beredning av kaffe

Vattnets temperatur kontrolleras under hela tillagningsprocessen, för att garantera stabilitet i extraktionsfasen. Specialista Prestigio erbjuder 3 bryggningstemperaturer* som motsvarar ett område mellan 92°C och i 96°C.

Beroende på bönornas typ och rostning, rekommenderar vi olika temperaturer: Robusta bönor kräver en låg temperatur; Arabica bönor en hög temperatur. Detsamma gäller för bönor med mörkrostning eller för just malna bönor.

Temperaturnivå	Motsvarande varningslampa	Rostningsnivå
MIN	   	Mörkt
MED	   	Medium-mörkt
MAX	   	Ljust - Mörkt

* Denna temperaturen hänvisar till vattnet i thermoblock. Den är således annorlunda än temperaturen i koppen eller

temperaturen som uppmäts när drycken kommer ut från filterhållarens dispensrar.

5. FÖRBEREDELSE AV MJÖLKDRYCKER

5.1 Skumma mjölken

1. Häll mängden mjölk, i kannan, (C10) som du önskar värma/skumma, med hänsyn till att mjölkvolymen kommer att öka 2 eller 3 gånger (fig. 22). För att få ett tjockare och jämnare skum, rekommenderas det att använda helmjölk vid kylskåpstemperatur (ungefär 5°C).

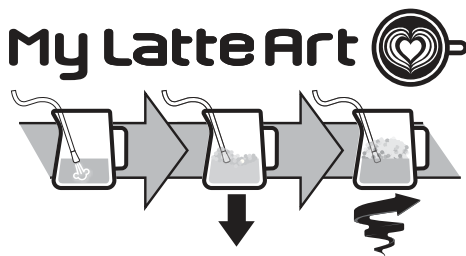

2. För att skumma mjölken, placera ångröret (A6) på mjölkens yta: på så sätt blandas luften med mjölken och ångan.
3. Håll ångröret på ytan, med uppmärksamhet att inte fånga upp för mycket luft och skapa alltför stora bubblor.
4. Sänk ner ångröret under mjölkytan: på så sätt skapas en virvel. När önskad temperatur uppnåtts, stäng ångvredet och vänta tills dispenseringen av ånga avbryts helt innan du avlägsnar mjölkkanan.

Bartendern rekommenderar:





- **Färsk mjölk är bäst.** Använd alltid färsk mjölk vid kylskåpstemperatur.
- För ett bättre resultat, rekommenderar vi att alltid förvara mjölkkanan i kylskåp.
- Helmjölk garanterar utmärkta resultat. Resultatet och skummets kvalitet skiftar beroende på om du använder komjölk eller vegetabiliska drycker.
- Efter att ha skummat mjölken, eliminera bubblorna genom att rotera mjölkkanan lätt.

Rengöring av ångröret:

1. Efter varje användning, avlägsna mjölkrester från ångröret med en duk (fig. 23). För en djup rengöring, rekommenderas det att använda Eco MultiClean: säkerställer hygienien genom att avlägsna proteiner och fetter från mjölken och kan användas för att rengöra hela maskinen.
2. Dispensera ånga några sekunder för att rengöra dispensern ordentligt (fig. 12).
3. Vänta tills dispensern svalnar för att bibehålla dispenserns prestanda i tiden, använd rengöringsnålen (C11) för att hålla de 3 hälen fria (fig. 24).







6. PERSONALISERA MÄNGDEN AV

KAFFEDRYCKERNA MED KNAPPEN (B7)

- Förbered maskinen för att dispensera 1 eller 2 koppar av kaffedrycken som du önskar dispensera, innan du hakar fast filterhållaren (C1) komplett med filter (C2) eller (C3) och malet kaffe.
- Vrid vredet (B8) för att välja drycken att programmera.
- Tryck in knappen : indikationslampan som motsvarar knappen  blinkar.
- Tryck in knappen OK för att starta dispenseringen. Varningslamporna motsvarande knapparna OK och  blinkar.
- När önskad mängd uppnåtts, tryck in OK. Om drycken förutser dispensering av en annan ingrediens, startar dispenseringen av denna: när önskad mängd uppnåtts, tryck in OK.
- Tryck in knappen  för att spara. Apparaten är klar för en ny användning och varningslampan  förblir tänd. Om du inte vill spara programmeringen, tryck in vilken annan knapp som helst.

Observera:

- Det är möjligt att programmera kaffedrycker, men inte dispensering av ånga och varmt vatten.
- Programmeringen ändrar mängden av dryckerna, men inte av det malna kaffet.
- Dryckerna "X2" kan programmeras separat.
- **För att gå tillbaka till fabriksinställningarna, håll knappen intryckt  tills den släcks. Den valda drycken går tillbaka till den fabriksinställda mängden.**

Kafferecept	Fabriksinställd mängd	Programmerbar mängd
 Espresso	35 ml	från 25 till 90 ml
 Espresso X2	70 ml	från 50 till 180 ml
 Coffee	80 ml	från 50 till 120 ml
 Coffee X2	160 ml	från 120 till 240 ml
 Americano	120 ml	<ul style="list-style-type: none"> • espresso: från 25 till 60 ml • vatten: från 25 till 120 ml
 Americano X2	240 ml	<ul style="list-style-type: none"> • espresso: från 50 till 120 ml • vatten: från 50 till 240 ml







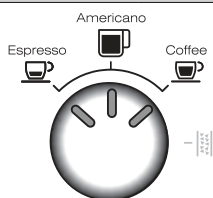

7. INSTÄLLNINGSMENY

1. Gå in i menyn:

Tryck in samtidigt i 5 sekunder	x2	
---------------------------------	----	--

2. Inställningar med val från vredet (B8)



Motsvarande inställning	Vrid till	Justeringar
Extra justering av malningen	 Espresso	x2 → Range 1
		 → Range 2
Vatt. hårdh	 Americano	x2 → mjukt
		 → medium
		 → hårt/mycket hårt
Automatisk avstängning	 Coffee	x2 → 9 minuter
		 → 1,5 timmar
		 → 3 timmar

3. Inställningar med val från knapp:

Energisparläge	 → Aktiverad
	 → Avstängd
Fabriksvärden	Håll knappen  , intryckt i minst 5 sekunder tills varningslampan förblir tänd med fast ljus

4. Spara de nya inställningarna genom att trycka in ON/Standby (B1)

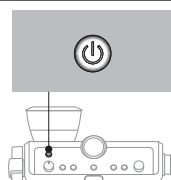











8. RENGÖRING AV APPARATEN

Varning!

- Använd inte lösningsmedel, abrasiva rengöringsmedel eller alkohol för rengöring av maskinen.
- Använd inte metallföremål för att avlägsna kalkavlagringar och kaffeavlagringar, eftersom dessa skulle kunna repa metall- och plastytorna.
- För perioder av stillastående över en vecka, rekommenderas det, före användning av maskinen, att utföra en sköljning.

Fara!



- Sänk aldrig ned maskinen i vatten, under rengöringen: det rör sig om en elektrisk apparat.
- Före varje rengöring av apparatens ytterdelar ska du stänga av maskinen, ta ut stickkontakten ur vägguttaget och låta maskinen svalna.

					
	×	✓	✓	×	×
	✓	×	×	✓	✓
	×	×	×	✓	✓
	×	×	×	✓	✓
	×	×	✓	✓	×
	×	×	×	✓	✓

8.1 Rengöring av kaffedispensern

När varningslampan  tänds (orange) (B13), är det nödvändigt att utföra rengöringen av kaffekretsen. För att utföra rengöringscykeln, köp pastillerna för rengöring av kaffemaskiner. För ytterligare informationer, besök www.Delonghi.com.



1. För in filtret för 1 kopp (C2) i filterhållaren (C1) (fig. 25).
2. För in rengöringstillbehöret i filtret (C8) (fig. 25) och tryck till botten.
3. Placera rengöringspastillen på tillbehöret (fig. 26).
4. Fäst filterhållaren på kaffedispensern (A18).

5. Fyll vattentanken (A14). Försäkra dig att droppkaret (A10) är tomt.
6. Håll knappen  (B6) intryckt, tills varningslampan tänds  (B13). Efter några minuter avbryts rengöringen automatiskt.
7. Avlägsna filterhållaren och rengöringstillbehöret.
8. Diska filterhållaren och filtret under rinnande vatten.
9. Sätt tillbaka filterhållaren och utför en sköljning genom att trycka in knappen  : vi rekommenderar att placera en tom behållare under filterbehållaren.
10. Avlägsna och töm droppkaret.

Observera:

Denna rengöringscykel kan startas när som helst genom att trycka in knappen  i några sekunder. För att radera proceduren, tryck in knappen i 10 sekunder.

8.2 Rengör facket för behållaren för kaffeböner

1. Försäkra dig att behållaren för kaffeböner (A2) är tom. Utför eventuellt några malningar utan böner och töm den.
2. Haka av behållaren genom att vrida den moturs och dra ut den ur maskinen (fig. 27)
3. Sug upp kafferesterna (fig. 28).
4. Rengör utrymmet för behållaren för kaffeböner med en fuktig trasa och torka (fig. 29);
5. Sätt tillbaka behållaren genom att föra in den i kaffekvarnen. Behållaren är korrekt införd när pilen  är inriktad med symbolen  och du hör ett "klick" (fig.30).

8.3 Rengöring av kvarnarna

När du rengör behållaren för kaffeböner (A2), rengör behållarens utrymme och den övre kvarnen med en fuktig trasa. Kontakta ett service center för att avlägsna och byta ut kvarnarna. Det är möjligt att avlägsna kvarnen om maskinen skulle vara blockerad av ett främmande föremål. Om detta skulle inträffa, avlägsna behållaren för kaffeböner och gör så här:

1. Haka filterkoppen (C1) och utför en "tom" malning för att befria kaffekanalerna.
2. Stäng av apparaten.
3. Vrid malningsregulatorn moturs, till gränsläget, i läge "RE-MOVE" (fig. 31).
4. Dra ut kvarnens övre del, genom att gripa den med det särskilda handtaget (fig.32).
5. Rengör maskinen med en pensel (fig. 33) och sug upp resterna av kaffe med en dammsugare (fig. 28).

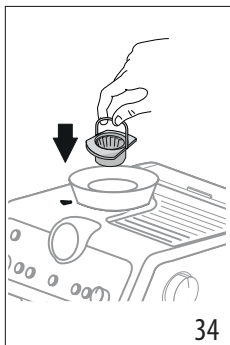
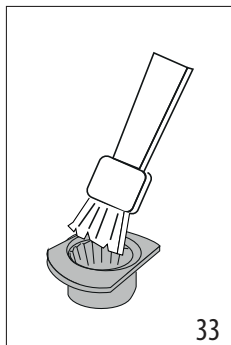

6. För in kvarnen i dess utrymme (fig. 34);
7. Vrid regulatoren och välj önskad malningsgrad (fig. 14);
Kontrollera att kvarnen är väl införd, genom att dra i handtaget: kvarnen är korrekt införd om den inte rör sig.

8.4 Utbyte av kvarnarna

När mängden malet kaffe minskar ytterligare, kontakta ett service center för att byta ut kvarnarna och justera sedan kaffekvarnen igen genom att gå in i inställningsmenyn ("7. Inställningsmeny") och välja det första området för extra justering av malningen. Vrid sedan ratten för justering av mängden (B2) till läge MIN och justera dosen som vid första användningen (se "Den perfekta dosen").

8.5 Rengöring av "Smart tamping station"

1. Rengör fasthåkningsområdet med en pensel (fig. 35).
2. Dra i spaken (A20) till ändläget och rengör pressen med en pensel (fig. 36), släpp sedan spaken.
3. Rengör med hjälp av skrapan (C7), glidbanan för kaffet (fig. 37).

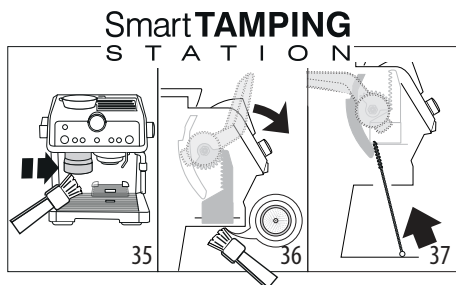

1. Ta ut den medföljande reaktionssticken "TOTAL HARDNESS TEST" ur förpackningen (C4).
2. För in sticken helt i ett glas vatten i ungefär en sekund.
3. Dra upp remsan ur vatten och skaka lätt. Ställ in apparaten, som anges i kapitlet "7. Inställningsmeny".

Testresultat Hårdhet	Vattnets	Knapp	Nivå
		×2	1 mjukt vatten
		≡ ♂	2 medelhårt vatten
		OK	3 hårt eller mycket hårt vatten

4. Ställ in apparaten, som anges i kapitlet "7. Inställningsmeny".

10. HUR MAN ANVÄNDER SOFTBALLS

Softballs (C9) är ett innovativt system som förlänger maskinens livstid, utan att förändra vattnets kvalitet och garanterar en dispensering av krämigt och aromatiskt kaffe. För att optimera effektiviteten, lämna Softballs i vattnet hela natten före användningen.

1. Dra ut Softballs-paketet ur förpackningen (fig. 38).

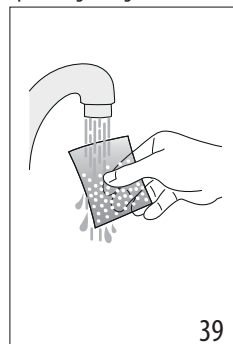
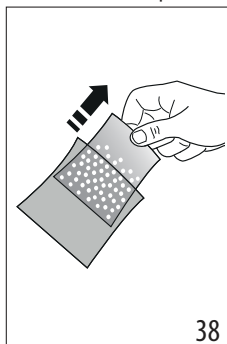

2. Skölj Softballs-paketet med rinnande vatten (fig. 39).
3. Sänk ner påsen i vattentanken (A14) (fig. 40).

9. VATTNETS HÅRDHET

Indikationslampan (B9) avkalkning, tänds efter en förhandsbestämd funktionstid, som beror på vattnets hårdhet. Det är möjligt att programmera maskinen beroende på vattnets verkliga hårdhetsgrad i de olika regionerna, och på så sätt göra proceduren för avkalkning mindre frekvent.

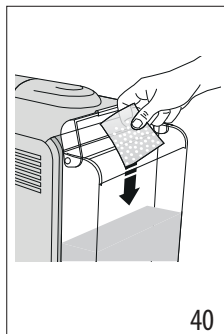

4. Byt ut Softballs-påsen var 3:e månad (fig. 41).

11. AVKALKNING

Varning!

- Före användningen läs instruktionerna och etiketterna på avkalkningsmedlet (C5), som återges på själva avkalkningsmedlets behållare.
- Vi rekommenderar att använda uteslutande avkalkningsmedel från De'Longhi. Användning av ej lämpliga avkalkningsmedel, liksom ej regelmässigt utförd avkalkning, kan medföra uppkomst av defekter, som inte täcks av tillverkarens garanti.
- Avkalkningsmedlet kan skada de ömtåliga ytorna. Om produkten hålls ut oavsiktligt, torka upp omedelbart.

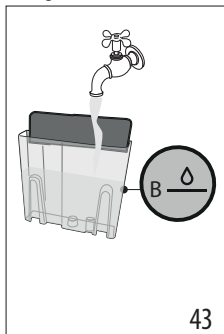
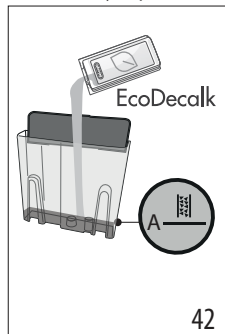

För att utföra avkalkningen	
Avkalkningsmedel	Avkalkningsmedel De'Longhi
Behållare	Kapacitet 2 liter
Tid	~40min

1. (OM NÄRVARANDE, TA UT AVHÄRDNINGSFILTRET OCH SOFTBALLS). Häll avkalkningsmedlet i vattentanken (A14) till nivån A  A (motsvarande en förpackning på 100ml) som är tryckt på tankens insida (fig. 42).

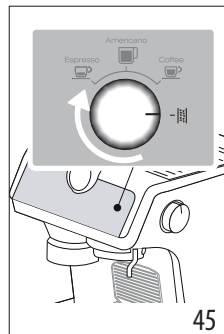
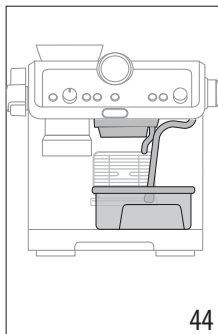

2. Tillsätt vatten tills nivån  B nås (fig. 43). För sedan in vattentanken i maskinen igen.



3. Försäkra dig att filterhållaren (C1) inte är fasthakad och placera en behållare under dispensarna för kaffe och varmt vatten, och under ångröret (A6) (fig. 44).
4. Vrid vredet (B8) på  (fig. 45): varningslampan OK tänds med orange färg; varningslampan  blinkar.
5. Tryck in knappen OK: varningslampan OK blinkar.
6. Avkalkningsprogrammet startar och avkalkningsmedlet kommer ut från dispensarna. Avkalkningsprogrammet utför automatiskt en rad sköljningar med intervaller, för att avlägsna kalkavlagringarna från kaffemaskinens inandöme tills behållaren töms.

Dispenseringen avbryts och varningslampan OK blir vit. Det är således nödvändigt att utföra sköljningscykeln:

7. Töm behållaren som använts för att samla upp avkalkningsvätskan och sätt tillbaka den under dispensarna.
8. Dra ut vattentanken, töm den från eventuella rester av avkalkningsmedel, skölj den med rinnande vatten och fyll den med färskt vatten upp till MAX nivån (fig. 46). För sedan in tanken i dess utrymme.

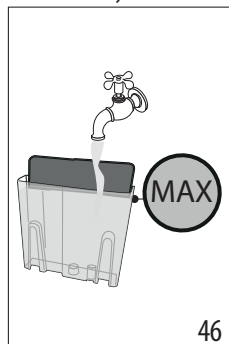

9. Tryck in knappen OK: sköljningen startar.
10. När sköljningen har fullbordats, avbryts dispenseringen och apparaten är klar för användning.











11. Töm behållarna för uppsamling av sköljvattnet.
12. Dra ut och töm droppkaret och för sedan in det igen.
13. Dra ut och fyll tanken med färskt vatten och sätt sedan tillbaka den.





Maskinen är nu redo för användning.







Observera:

- Avkalkningscykeln kan startas när som helst (även om den relativa varningslampan ännu inte är tänd).
- Om avkalkningen skulle ha startats av misstag, tryck in knappen OK i 10 sekunder, sköljningen kan inte avbrytas.

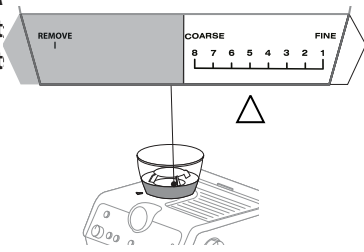
12. INDIKATIONSLAMPORNAS BETYDELSE



INDIKATIONSLAMPOR	INDIKATIONSLAMPORNAS BETYDELSE	ÅTGÄRD
Alla indikationslamporna blinkar samtidigt	Påslagning av maskinen	Självd diagnos
 fast	Det är den första påslagningen av maskinen och det är nödvändigt att utföra påfyllningen av vattenkretsen	Utför vad som anges i kap. "3. Första ibruktagandet av maskinen"
 fast (vit) • Indikationslampa  : anger den valda kaffetemperaturen • Indikationslampa  : anger att maskinen är redo att dispensera varmt vatten	Maskinen är klar för dispensering	Förbered maskinen och fortsätt med beredningen av drycken
 fast	Energibesparingen är aktiverad	Se kap. "7. Inställningsmeny" om du önskar inaktivera funktionen
 fast	Behållaren för kaffeböner (A2) är tom	Fyll på behållaren för kaffeböner
 blinkande	Om du vill fortsätta med malningen, men behållaren för kaffeböner (A2) är tom	Fyll på behållaren för kaffeböner
 blinkar kortvarigt med jämna intervaller	Vredet (B2) är vridet till läget för maximal reglering 	Om kaffet i filtret efter malningen är otillräckligt, välj ett nytt malningsområde, som anges i kapitel "7. Inställningsmeny".
 fast	Vattnet i tanken (A14) är inte tillräckligt eller så är inte kaffetanken ordentligt införd	Fyll på tanken eller dra ut och sätt tillbaka tanken korrekt
		→

INDIKATIONSLAMPOR	INDIKATIONSLAMPORNAS BETYDELSE	ÅTGÄRD
 blinkande	Du vill bereda en dryck men vattentanken (A14) är tom	Fyll vattenbehållaren
	Malningen är för fin och kaffet kommer därför ut för långsamt eller inte alls	Dra ut filterhållaren (C1), upprepa procedurerna för att bereda kaffet, med hänsyn till indikationerna i avs. "4.1 Fas 1 - Malning (grinding)" och "4.2 Fas 2 - Pressning (tamping)"
	Kaffefiltret (C2) eller (C3) är igensatt	Skölj filtret under rinnande vatten
	Tanken (A14) är felaktigt införd och de relativa ventilerna är öppna	Tryck lätt på tanken så att ventilerna öppnas
	Kalk på hydraulkretsens insida	Utför avkalkning som i kap. "11. Avkalkning"
 fast	Apparaten är klar för dispensering av ånga	Apparaten har uppnått temperaturen för att dispensera ånga. För att utföra dispenseringen, vrid ångvredet (A4)
 blinkande	Apparaten är påslagen och energibesparingen är aktiverad: ångvredet (A4) är i läge för att dispensera ånga	Indikationslampan blinkar för att ange att apparaten förbereder sig för att dispensera ånga: dispensereringen startar så snart apparaten nått temperaturen
	Apparaten är klar för dispensering av ånga	Apparaten är vid temperatur för beredning av ånga när varningslampan lyser med fast ljus
	Apparaten dispenserar ånga	
 fast	Behållaren för kaffeböner är inte införd	För in behållaren för kaffeböner korrekt (A2) eller kontrollera att den är korrekt införd. Behållaren är korrekt införd när pilen ▲ är inriktad med symbolen ☞ och du hör ett "klick"
		→

INDIKATIONSLAMPOR	INDIKATIONSLAMPORNAS BETYDELSE	ÅTGÄRD
 blinkande	<p>Justeringen av väljaren för malningsgrad är inte korrekt eller är utöver den maximalt möjliga justeringen</p> <p>UTANFÖR området korrekt</p>  <p>Område korrekt range</p>	<p>För tillbaka väljaren till ett av lägena för malning (mellan 1 och 8) och kom ihåg att:</p> <ul style="list-style-type: none"> • Justera malningen medan kaffekvarnen är igång • Justera med en nivå åt gången och utföra minst 5 malningar mellan en justering och den påföljande
 fast	<p>Apparaten kräver pressning</p> <p>Filterhållaren har hakats av kaffekvarnen utan att pressa</p> <p>Filterhållaren har hakats av innan malningen avslutats eller så har pressningen utförts för tidigt</p> <p>Kaffekvarnens glidbana är igentäppt</p> <p>Kvarnarna är blockerade av ett främmande föremål</p>	<p>En malning har just utförts och kaffefiltret är fasthakat på kaffekvarnen</p> <p>Haka av kaffefiltret och fortsätt genom att pressa kaffet som beskrivs i avs. "Den "perfekta dosen"" "Om du använder föremålet kaffe:"</p> <p>Upprepa malningen</p> <p>Utför rengöringen enligt avs. "8.5 Rengöring av "Smart tamping station"". Om felet kvarstår, kom åt glidbanan genom att öppna den därför avsedda luckan och befria den med användning av borsten</p> <p>Avlägsna det främmande föremålet och rengör kvarnarna enligt avs. "8.3 Rengöring av kvarnarna".</p>
 fast (rött)	<p>Det är nödvändigt att utföra avkalkningen</p>	<p>Utför avkalkningen som illustreras i kap. "11. Avkalkning"</p>
 blinkar (rött) +  blinkar (orange)	<p>Apparaten utför avkalkningen</p>	<p>Fortsätt och komplettera proceduren som beskrivs i kap. "11. Avkalkning"</p>
 blinkar (rött) +  fast (vitt)	<p>Det är nödvändigt att utföra sköljningen</p>	
→		

INDIKATIONSLAMPOR	INDIKATIONSLAMPORNAS BETYDELSE	ÅTGÄRD
 blinkar (rött) +  blinkar (vitt)	Apparaten utför avkalkningscykelns sköljning	
 fast (orange)	Det är nödvändigt att utföra rengöringen av kaffedispensern	Se par. "8.1 Rengöring av kaffedispensern"
 blinkande (orange)	Apparaten utför rengöring av kaffedispensern	
Alla varningslamporna blinkar	Allmänt larm	Kontakta ett servis center

13. OM NÅGOT INTE FUNGERAR

FEL	ORSAK	LÖSNING
Det finns vatten i droppkaret (A10)	Det är en del av den normala funktionen av maskinens interna kretsar	Töm och rengör regelbundet droppkaret
Det kommer inget mer espressokaffe	För lite vatten i behållaren (A14)	Fyll behållaren
	Indikationslampan  (B6) är tänd för att ange att kaffekretsen eller ångkretsen är tom	Tryck in knappen som motsvarar varningsslampan  för att fylla kretsen
	Filtret (C2) eller (C3) är igentäppt	Skölj filtret under rinnande vatten
	Behållaren (A14) är felaktigt isatt och ventilerna i botten är inte öppna	Tryck lätt på behållaren för att öppna ventilerna i botten
	Kalk på hydraulkretsens insida	Utför avkalkning som i kap. "11. Avkalkning"
Alltför finmalet		Dra ut filterhållaren (C1), upprepa procedurerna för att bereda kaffet, med hänsyn till indikationerna i avs. "4.1 Fas 1 - Malning (grinding)" och "4.2 Fas 2 - Pressning (tamping)"
Filterhållaren hakar inte fast på apparaten	Det malna kaffet har inte pressats eller är överdrivet	Upprepa malningen med annorlunda inställningar. Minska dosen: kontrollera att filtret (C2) eller (C3) (1 eller 2 koppar) är korrekt för dosen som ska malas (knapp 2x (B3) vald eller inte)
Espressokaffet droppar från filterhållarens (C1) kanter istället för från hålen	Filterhållaren är dåligt införd	Haka fast filterhållaren korrekt och vrid den med kraft ända ner i botten
	Kaffedispenserns packning (A18) har förlorat elasticitet eller är smutsig	Byt ut kaffedispenserns packning hos ett service center
	Filtret (C2) eller (C3) är igentäppt	Skölj filtret under rinnande vatten
→		

FEL	ORSAK	LÖSNING
Krämen på kaffet är ljus (kaffet rinner snabbt från munstycket)	Det är nödvändigt att se över apparatens inställningar	Dra ut filterhållaren, upprepa procedurerna för att bereda kaffet, med hänsyn till indikationerna i avs. "4.1 Fas 1 - Malning (grinding)" och "4.2 Fas 2 - Pressning (tamping)"
Krämen på kaffet är mörk (kaffet rinner långsamt från pipen)	Det är nödvändigt att se över apparatens inställningar	Dra ut filterhållaren (C1), upprepa procedurerna för att bereda kaffet, med hänsyn till indikationerna i avs. "4.1 Fas 1 - Malning (grinding)" och "4.2 Fas 2 - Pressning (tamping)"
Vid avslutad avkalkning kräver apparaten ytterligare en sköljning	Behållaren har inte fyllts till MAX-nivå under sköljningen	Upprepa sköljningen (se kap. "11. Avkalkning")
Apparaten maler inte kaffe	Det finns ett främmande föremål inuti kaffekvarnen	Utför rengöringen av kvarnarna enligt avs. "8.3 Rengöring av kvarnarna", och försäkra dig att du avlägsnat alla bönorna från behållaren för kaffeböner (A2) innan du drar ut den. Innan du för in kvarnen, sug noggrant ut alla rester från dess utrymme
	Behållaren för kaffeböner (A2) är inte i rätt läge	Behållaren är korrekt införd när pilen ▲ är inriktad med symbolen  och du hör ett "klick"
Om du önskar byta kaffesort	Det är nödvändigt att avlägsna alla kaffebönorna i maskinen	<ul style="list-style-type: none"> • Töm behållaren för kaffeböner (A2) (genom att utföra tomma malningar eller eventuellt suga upp de kvarstående bönorna) • Haka fast filterhållaren (C1) och utför "tomma" malningar, för att befria kaffekanalerna: haka sedan fast filterhållaren vid kaffekvarnens utgång (A19) räkta in texten INSERT och vrid filterhållaren åt höger. Malningen startar när filterhållaren når läget CLOSE och avbryts automatiskt. Upprepa tills filtret är tomt • För in i behållaren (A2) den nya typen av kaffeböner • Om den "perfekta dosen" inte uppnås vid malningen, upprepa proceduren för första användningen
		→

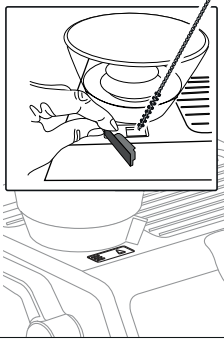
FEL	ORSAK	LÖSNING
<p>Kaffefiltret (C2) eller (C3) är tomt efter malningen</p> <p>Efter malningen är kaffepulvret i filtret för mycket</p>	<p>Kaffekvarnens glidbana är igentäppt</p>	<p>Utför rengöringen enligt avsnitt 8.5 "Rengöring av Smart tamping station". Om felet kvarstår, kom åt glidbanan genom att öppna den däravsedda luckan (A21) och befria den med användning av borsten</p> 
<p>Efter malningen uppnår inte kaffet i filtret (C2) eller (C3) den "perfekta dosen"</p>	<p>"Smart Tamping Station" behöver rengöras</p> <p>Det är nödvändigt att justera mängden malet kaffe</p> <p>Kvarnarna slits med tiden</p>	<p>Utför rengöringen enligt avsnitt 8.5 "Rengöring av Smart tamping station", upprepa sedan malningen</p> <p>Justera mängden med det avsedda vredet (B2) genom att följa indikationerna i avsnitt 7 "Den perfekta dosen". Om vredet redan är i läge max, fortsätt som anges i avsnitt 7 "Inställningsmeny" - "Extra justering av malningen"</p> <p>Utför bytet av kvarnarna enligt indikationerna i avsnitt 8.4 "Utbyte av kvarnarna"</p>

Læs altid sikkerhedsadvarselne inden du bruger maskinen.

1. BESKRIVELSE

1.1 Beskrivelse af maskinen - A

- A1. Låg til kaffebønnebeholder
- A2. Kaffebønnebeholder
- A3. Kopbakke
- A4. Dampknap
- A5. Varmtvandsudløb
- A6. Dampdyse
- A7. Rist til kopbakke til espresso
- A8. Rist til kopbakke til glas eller krus
- A9. Bakkerist
- A10. Drypbakke
- A11. Vandniveaumåler i drypbakke
- A12. Låg til vandbeholder
- A13. Håndtag til udtag af vandbeholder
- A14. Vandbeholder
- A15. Leje til kalkfilter
- A16. Leje til strømstik
- A17. Hovedafbryder (ON/OFF)
- A18. Kaffeudløb
- A19. Udtag til kaffekværn (Tamping station)
- A20. Stempel
- A21. Luge der giver adgang til kaffekværn

1.2 Beskrivelse af kontrolpanelet - B

- B1. Knap til ON/Standby
- B2. Knap til regulering af mængde formalet kaffe
- B3. "X2"-knap til brug af filteret 2 kopper kaffe
- B4. "Kaffe-temperatur"-knap
- B5. "OK" knap: til udledning af drik/bekræftelse af drik
- B6. Knap til "udledning af varmt vand"
- B7. "My" knap: til indstilling af foretrukken mængde af drik
- B8. Knap til funktionsvalg
 - Espresso
 - Americano
 - Coffee
 - Afkalkning
- B9. Kontrollampe for anmodning om "afkalkning"
- B10. Kontrollampe "damp klar"
- B11. "Bønnebeholder mangler"-knap
- B12. Kontrollampe "energibesparelse"
- B13. Kontrollampe "Rengøring" (se "8.1 Rengøring af kaffebryggeren")
- B14. "Bønneneholder tom"-kontrollampe
- B15. Kontrollampe "vandmangel"
- B16. Kontrollampe "tryk"
- B17. Manometer

1.3 Beskrivelse af tilbehøret - C

- C1. Filterholder
- C2. Filter til 1 kop
- C3. Filter til 2 kopper
- C4. Målestrimmel "Total Hardness Test"
- C5. Afkalkningsmiddel
- C6. Aftaglig el-ledning
- C7. Børste
- C8. Tilbehør til rengøring af kaffeudløb
- C9. Softballs
- C10. Mælkekande
- C11. Rengøringsnål til dampdyse

1.4 Rengøringstilbehør ikke inkluderet, anbefalet af producenten

For mere information, besøg Delonghi.com.



Rengøringstabletter

(Se "8.1 Rengøring af kaffebryggeren")

ØEcoMultiClean Vaskemiddel

EAN: 8004399333307

2. TÆNDING AF MASKINEN

Vask tilbehøret med lunkent vand og opvaskemiddel og fortsæt som følger:

1. Indsæt bønnebeholderen (A2) i kaffekværnen (fig. 1). Beholderen er isat korrekt, når pilen ▲ er justeret med symbolet ☒, og der høres et "klik" (fig. 2).
2. Indsæt drypbakken (A10) inklusive kopbakkeristen (A8) og bakkeristen (A9) (fig 3);
3. Tag vandbeholderen ud (A14) (fig 4) og fyld den op med frisk, rent vand. Pas på, at vandet ikke overstiger MAX-strengen (fig. 5).
4. Genindsæt beholderen.

Advarsel: Tænd aldrig for maskinen, hvis der ikke er vand i beholderen, eller hvis beholderen er blevet fjernet.

Bemærk venligst: Det anbefales at tilpasse vandhårhedsgraden snarest muligt ved at følge proceduren, beskrevet i kapitel "7. Menu indstillinger".

3. FØRSTE ANVENDELSE AF MASKINEN

1. Sæt strømstikket (C6) i lejet (A16) på bagsiden af maskinen (fig. 6); sæt derefter stikket i stikkontakten. Sørg for, at hovedafbryderen (A17) på bagsiden af maskinen er blevet tændt I (fig. 7);
2. Anbring en beholder med en minimumskapacitet på 100 ml under varmtvandsbeholderen (nær kaffedispenseren (A18)) (fig. 8);
3. Tryk på knappen (B6) der svarer til kontrollampen ☒ (fig. 9): brygningen begynder og afbrydes automatisk. Tøm beholderen.

Inden maskinen tages i brug er det nødvendigt at skylle alle interne kredsløb igennem. Gå frem som følger:

4. Isæt filterholderen (C1) på maskinen: for at sætte den rigtigt i skal håndtaget på filterholderen være lige ud for symbolet "INSERT" (fig. 10) og drej håndtaget mod højre indtil det er lige ud for "CLOSE";
5. Sæt en beholder under filterholderkoppen og dampdysen (A6);
6. Tryk på knappen OK (B5) (fig. 11): brygningen begynder;
7. Efter brygningen drejes dampknappen (A4) (fig. 12) og dampdyse i et par sekunder for at skylle dampkredsløbet: For optimal dampudløb anbefales det at gentage denne handling 3 eller 4 gange. Dette tillader, at vandet i røret elimineres, før der laves damp.

Nu er maskinen klar til brug.

Bemærk venligst: Hvis maskinen ikke har været i brug i længere tid anbefales det at skylle det interne kredsløb.

Første gang du bruger maskinen, skal der laves 4-5 kopper kaffe, inden kaffemaskinen begynder at give et tilfredsstillende resultat: vær særligt opmærksom på den doserede mængde formalet kaffe i filtret ((C2) eller (C3)) (se vejledningen i afsnit "4.1 Fase 1 - Formaling").

Fortsæt som angivet i kapitel "Den "perfekte dosis"".

4. KAFFETILBEREDNING

4.1 Fase 1 - Formaling

1. Hæld bønnerne i beholderen (A2) (fig. 13). Det tilrådes kun at bruge de nødvendige bønner til tilberedning: på denne måde bruger du altid frisk kaffe;
2. Vælg malegrad (fig. 14). Fabriksindstillingen er 5 (medium maling). Hvis resultatet ikke er tilfredsstillende, skal niveauet justeres efter personlig smag og typen af kaffe (justeringen skal foretages, mens kaffekværnen kører).

Bemærk venligst: Der anbefales en malegrad på mellem 3 og 6 til de fleste slags kaffe. Malingsresultatet ved valg af 1 eller 2 er meget fint og bruges kun til en meget særlig slags kaffe (let ristet).

3. Indsæt et af kaffefiltrene (C2) eller (C3) i filterholderen (C1) (fig. 15). Hvis du bruger filteret til 2 kopper, skal du trykke på X2-knappen (B3): med dette valg fordobles også den leverede mængde espresso.
4. Juster kvantitetsknappen (B2) startende fra minimumspositionen (fig. 16).

Se afsnit "Reguler mængden af formalet kaffe i filtret" for yderligere information.

5. Sæt filterholderen på kaffekværnens udtag (A19) centrert den med skriften INSERT: drej filterholderen mod højre. Formalingen begynder når filterholderen står på CLOSE og den stopper automatisk.

Reguler mængden af formalet kaffe i filtret

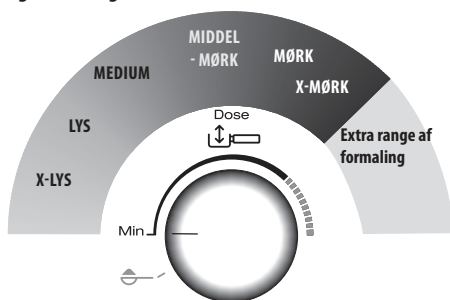

Hver sort af bønner giver forskellige resultater under formaling, og af denne grund kræver dosisjusteringen forsigtighed i starten.

Denne illustration giver indikationer på, hvordan dosis justeres, baseret på ristefarven: det skal betragtes som et udgangspunkt, men det kan variere alt efter kaffebønnernes sammensætning.

1. Indstil dosis fra minimumspositionen.
2. Drej langsomt på knappen med henvisning til din kaffes ristefarve.

4.2 Fase 2 - Stampning

1. Efter formalingen presses håndtaget (A20) ned så langt som muligt (tag ikke filterholderen ud) (fig. 17). Gentag 2 gange for at få det bedste resultat.
2. Hold håndtaget så langt nede som muligt, mens du fjerner filterholderen (fig. 18). Sæt derefter håndtaget tilbage i dets oprindelige position.
3. Når du har kontrolleret, at kaffedosis er korrekt (se "Den "perfekte dosis""), skal du fastgøre filterholderen til kaffedudløbet (A18) (fig. 19).

Bemærk venligst: Hvis der efter stampning er kafferester langs filterets kanter, påvirker dette på ingen måde kvaliteten af ekstraktionen og derfor det endelige resultat.

Den "perfekte dosis"

- Kaffefiltrene har et indvendigt referencemærke, der viser den perfekte mængde.



- Filtre med lasermærkning: den perfekte mængde svarer til mærkningens øverste linje;
- Filtre med præget mærkning: den perfekte mængde svarer til den frmhævede linje;
- Sørg for, at kaffen er på niveau efter presning. Det kan være nødvendigt at justere knappen flere gange (B2), før du når den perfekte dosis.

- Hvis kaffen over- eller underekstraheres, og dosis er inden for den perfekte dosis, skal du justere graden afformaling finere eller grovere (se "4.1 Fase 1 - Formaling"). Hvis kaffen overekstraheres (for langsom brygning), skal formalingen være grovere. Hvis kaffen er underekstraheret (for hurtigt brygning) skal formalingen være finere.
- **Baristaen anbefaler:** Fjern filterholderen, mens pressehåndtaget (A20) er sænket for at opnå en perfekt finish på kaffedosis.
- **Hvis der bruges formalet kaffe:**
 - Hæld den formalede kaffe i filtret;
 - drej justeringsknappen til ;
 - fastgør filterholderen til kaffekværnens udløb;
 - sænk og pres på håndtaget.













4.3 Fase 3 - Brygning

1. Vælg temperatur (fig. 20) (se "Temperaturen til tilberedning af kaffe").
2. Vælg den ønskede drik (fig. 21).
3. Tryk på OK (B5) for at starte brygning (fig. 11) (præinfusion og infusion). Kaffebrygningen stopper automatisk.

Temperaturen til tilberedning af kaffe

Vandtemperaturen styres under hele forberedelsesprocessen for at sikre dens stabilitet under udløbsfasen. La Specialista Prestigio byder på 3 bryggetemperaturer*, som svarer til et niveau mellem 92°C og 96°C.

Alt efter kaffebønnernes sort og ristning anbefales forskellige temperaturer: Robustabønner kræver lav temperatur; Arabica-bønner høj temperatur. Det samme gælder for mørkristede bønner eller letristede bønner.

Temperaturniveau	Tilsvarende kontrollampe	Ristningsniveau
MIN	   	Mørk
MED	   	Middel-mørk
MAKS	   	Lys - mørk

* Denne temperatur henviser til vandet i termoblokken. Den er derfor forskellig fra temperaturen på drikkevaren i koppen eller den temperatur, der måles, når drikkevaren forlader filterholderens dispensere.

5. TILBEREDNING AF MÆLKEDRIKKE

5.1 At skumme mælken

1. Hæld den mængde mælk i kanden (C10) som skal varmes/ skummes, under hensyntagen til, at mængden af mælk øges med 2 eller 3 gange (fig. 22). For at opnå et mere tæt og homogent skum anbefales det at bruge sødmælk ved køleskabstemperatur (ca. 5°C).

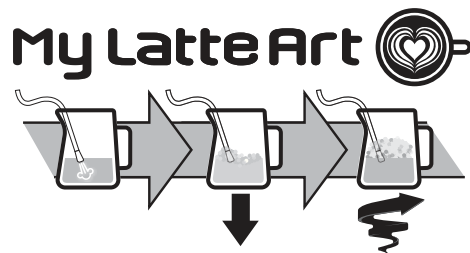

2. For at skumme mælken skal du placere dampdysen (A6) på mælken overflade. Derved blandes luften med mælken og dampen.
3. Hold dampdysen på overfladen, pas på ikke at opsamle for meget luft og skabe for store bobler.
4. Nedsænk dampdysen under mælken overflade: dette skaber en hvirvel. Når den ønskede temperatur er nået luk dampknappen og vent på, at damptilførslen stopper helt, for mælkekanden fjernes.





Baristaen anbefaler:

- **Frisk mælk er bedst.** Brug altid frisk mælk ved køleskabstemperatur.
- For et bedre resultat anbefales det altid at sætte mælkekanden tilbage i køleskabet.
- Sødmælk sikrer fremragende resultater. Resultatet og skummet struktur varierer alt efter den anvendte komælk eller vegetabiliske drikkevarer.
- Efter at have skummet mælken, fjernes boblerne ved at rotere mælkekanden let.

Rengøring af dampdysen:

1. Fjern alle mælkerester fra dampdysen efter hver brug med en klud (fig. 23). Til grundig rengøring tilrådes det at bruge Eco MultiClean: det sikrer hygiejne ved at fjerne mælkeproteiner og fedtstoffer og kan bruges til at rengøre hele maskinen.
2. Lav damp i et par sekunder for at rengøre dysen grundigt (fig. 12).
3. Vent på at dispenseren afkøles: for at bevare dispenserens effektivitet gennem tiden bruges rengøringsnålen (C11) til at holde de 3 huller frie (fig. 24).







6. INDSTIL MÆNGDE AF VAND I KAFFERNE EFTER EGEN SMAG MED KNAPPEN (B7)

- Forbered maskinen på at udlede 1 eller 2 kopper ønsket kaffedrik indtil filterholderen (C1) er komplet med filter (C2) eller (C3) formalet kaffe.
- Drej på knappen (B8) for at vælge den drik, der skal programmeres.
- Tryk på knappen : Kontrollampen, der svarer til tasten  blinker.
- Tryk på OK-knappen for at starte brygningen. Kontrollampe, der svarer til OK og  blinker.
- Når den ønskede mængde er nået tryk på OK. Hvis drikken forudsiger brygningen af en anden ingrediens, begynder brygningen af sidstnævnte: når den ønskede mængde er nået trykkes på OK.
- Tryk på knappen  for at gemme. Maskinen er klar til ny brug, og kontrollampen  forbliver tændt.

Hvis man ikke vil gemme programmeringen trykkes på en hvilken som helst anden knap.

Bemærk venligst:

- Man kan programmere drikke med kaffe, men ikke brygning af damp og varmt vand.
- Programmeringen ændrer mængden af drikke, men ikke af den formalede kaffe.
- Drikkene "X2" kan programmeres separat.
- For at vende tilbage til fabriksindstillingerne, hold tasten  nede indtil den slukkes. Den valgte drik vender tilbage til fabriksindstillingsmængden.**

Kaffeopskrift	Fabrik-sindstilling-smængde	Programmerbar mængde
 Espresso	35 ml	fra 25 til 90 ml
 Espresso X2	70 ml	fra 50 til 180 ml
 Coffee	80 ml	fra 50 til 120 ml
 Coffee X2	160 ml	fra 120 til 240 ml
 Americano	120 ml	<ul style="list-style-type: none"> espresso: fra 25 til 60 ml vand: fra 25 til 120 ml
 Americano X2	240 ml	<ul style="list-style-type: none"> espresso: fra 50 til 120 ml vand: fra 50 til 240 ml







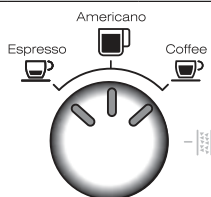

7. MENU INDSTILLINGER

1. Gå ind i menuen:



Tryk samtidigt i 5 sekunder	x2	
-----------------------------	----	--

2. Indstilling med justeringsknap (B8)



Tilsvarende indstilling	Drej til	Justeringer
Ekstra regulering af formaling		x2 → Range 1
		 → Range 2
Vandets hårdhedsgrad		x2 → blødt
		 → medium
		 → hårdt/meget hårdt
Auto-sluk		x2 → 9 minutter
		 → 1,5 time
		 → 3 timer

3. Indstilling med valg af knap:

Energibesparelse	 → Aktiv
	 → Slukket
Nulstil til standard	Hold  knappen nede i mindst 5 sekunder, indtil kontrollampen lyser konstant

4. Gem de nye indstillinger ved at trykke på ON/Standby (B1)

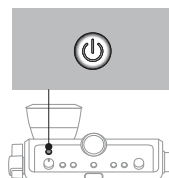











8. RENGØRING AF MASKINEN

Advarsel!

- Der må ikke anvendes opløsningsmidler, slibende rengøringsmidler eller sprit til rengøring af kaffemaskinen.
- Anvend ikke metalgenstande til at fjerne kalk eller kaffeaflejringer, da de kan ridse metal- eller plastkoverfladerne.
- I perioder hvor den ikke tages i brug i mere end en uge anbefales det at skylle den, før maskinen tages i brug.

Fare!



- Dyp aldrig maskinen i vand, når den rengøres: Kaffemaskinen er et elektrisk apparat.
- Inden apparatets udvendige dele rengøres, skal man slukke kaffemaskinen, tage stikket ud af stikkontakten og lade maskinen køle af.

					
	✗	✓	✓	✗	✗
	✓	✗	✗	✓	✓
	✗	✗	✗	✓	✓
	✗	✗	✗	✓	✓
	✗	✗	✓	✓	✗
	✗	✗	✗	✓	✓

8.1 Rengøring af kaffebyggeren

Når kontrollampen  tændes (orange) (B13), er det nødvendigt at rengøre kaffekredsløbet. For at køre rengøringscyklussen skal der købes rengøringstabletter til kaffemaskiner. For mere information, besøg www.Delonghi.com.



1. Indsæt filter til 1 kop (C2) i filterholderen (C1) (fig. 25).
2. Sæt rengøringsudstyret i filteret (C8) (fig. 25), og tryk det helt ned.
3. Sæt rengøringsabletten på tilbehøret (fig. 26).
4. Fastgør filterholderen til kaffebyggeren (A18).
5. Fyld vandtanken (A14). Sørg for, at drypbakken (A10) er tom.

6. Hold knappen nede  (B6) indtil kontrollampen tændes  (B13). Efter et par minutter stopper rengøringen automatisk.
7. Fjern filterholderen og rengøringstilbehøret.
8. Vask filterholderen og filteret under rindende vand.
9. Sæt filterholderen i igen, og fortsæt med skylning ved at trykke på knappen  : det anbefales at placere en beholder under filterholderen.
10. Fjern og tøm drypbakken.

Bemærk venligst:

Denne rengøringscyklus kan startes når som helst ved at trykke på knappen  i et par sekunder. For at annullere handlingen skal du trykke på knappen i 10 sekunder.

8.2 Rengør bønnebeholderens leje

1. Sørg for, at bønnebeholderen (A2) er tom. Forsæt om nødvendigt med et par tomme malinger for at tømme det.
2. Fjern beholderen ved at dreje den mod uret, og tag den ud af maskinen (fig. 27)
3. Støvsug kafferesterne op (fig. 28).
4. Rengør lejet til bønnebeholderen med en fugtig klud og tør (fig. 29);
5. Sæt beholderen i kaffekværnen igen. Beholderen er indsat korrekt, når pilen  er justeret med symbolet , og der høres et "klik" (fig.30).

8.3 Rengøring af kaffekværnene

Når du rengør bønnebeholderen (A2), skal du rengøre beholderens leje og den øverste kværn med en fugtig klud. Kontakt et servicecenter for at fjerne og udskifte kværnen.

Kværnen kan fjernes, hvis kværnen er blokeret af et fremmedlegeme. Hvis dette sker, fjern bønnebeholderen og fortsæt som følger:

1. Fastgør filterholderkoppen (C1), og udfør en "tom" formaling for at frigøre kaffekanalene.
2. Sluk for maskinen.
3. Drej formalingsregulatoren helt i bund imod urets retning, til "REMOVE" (fig. 31).
4. Tag det øverste af kværnen ud ved hjælp af dens håndtag (fig.32).
5. Rengør kværnen med en pensel (fig. 33) og støvsug kafferesterne (fig. 28).

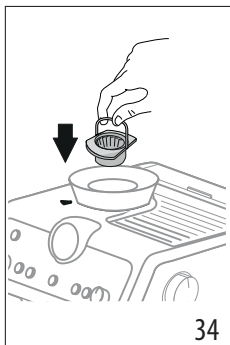
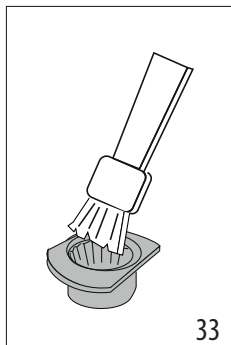

6. Genindtæt kværnen i lejet (fig. 34);
7. Drej regulatoren alt efter hvilken grad af formaling der ønskes (fig. 14);

Kontroller at kværnen er sat godt i ved at trække i håndtaget: kværnen er isat korrekt hvis ikke den bevæger sig.

8.4 Udskiftning af kaffekværnene

Når mængden af formalet kaffe reduceres yderligere, kontakt et servicecenter for at udskifte kværnen: Juster derefter kværnen igen ved at gå til indstillingsmenuen ("7. Menu indstillinger") og vælg det første interval for den ekstra formalingsjustering. Drej derefter mængdejusteringsknappen til (B2) MIN-position, og juster dosis som ved første brug (se "Den "perfekte dosis"").

8.5 Rengøring af "Smart tamping station"

1. Rengør påhægningsstedet med en pensel (fig. 35).
2. Træk i håndtaget (A20) i bund og rens stemplet med en lille pensel (fig. 36) og slip herefter håndtaget.
3. Rengør kaffetragten med den lille børste (C7) (fig. 37).

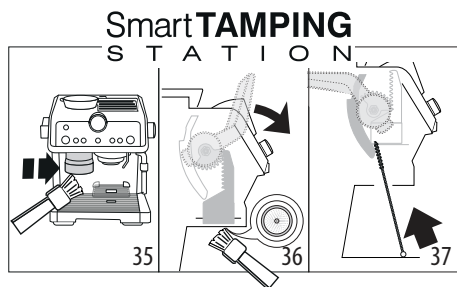

1. Tag den medfølgende teststrimmel "TOTAL HARDNESS TEST" ud af pakningen (C4).
2. Dyp strimlen helt ned i et glas vand i ca. et sekund.
3. Tag strimlen op af vandet, og ryst den let. Indstil maskinen som angivet i kapitel "7. Menu indstillinger".

Resultat af Hårdhedsgrad	Vandets	Knap	Niveau
		×2	1 blødt vand
		≡ 5	2 mellemhårdt vand
		OK	3 hårdt eller meget hårdt vand

4. Indstil maskinen som angivet i kapitel "7. Menu indstillinger".

10. SÅDAN BRUGES SOFTBALLS

Softballs (C9) er et innovativt system, der forlænger maskinens levetid uden at ændre vandets kvalitet, hvilket garanterer brygning af en cremet og aromatisk kaffe. For at maksimere effektiviteten skal du efterlade Softballs i vandet natten over inden brug.

1. Fjern pakken med Softballs fra emballagen (fig. 38).

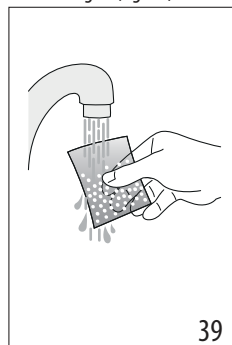
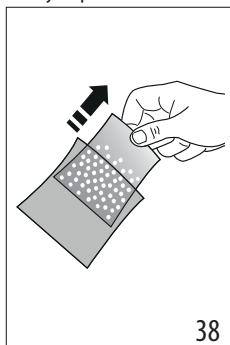

2. Skyl Softballpakken under rindende vand (fig. 39).
3. Sænk posen ned i vandtanken (A14) (fig. 40).

9. VANDETS HÅRDHEDSGRAD

Kontrollampen (B9), der indikerer afkalkning, tænder efter en forudbestemt periode, som afhænger af vandets hårdhedsgrad. Det er muligt at programmere kaffemaskinen i overensstemmelse med vandets reelle hårdhed i området. På den måde skal afkalkning udføres mindre ofte.

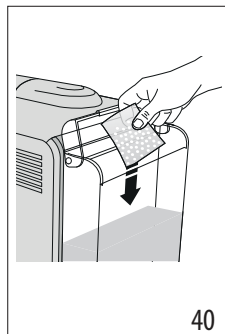

4. Udskift posen med Softballs hver 3. måned (fig. 41).

11. AFKALKNING

Advarsel!

- Læs instruktionerne og etiketten på afkalkningsmidlets pakning (C5), inden du afkalker maskinen.
- Det anbefales at kun anvende De'Longhi afkalkningsmiddel. Brugen af uegnede afkalkningsmidler samt uregelmæssig afkalkning, kan medføre, at der opstår fejl, som ikke dækkes af fabrikantens garanti.
- Afkalkningsmidlet kan beskadige sart overflader. Hvis produktet, ved et uheld, hældes ud, skal man straks tørre det op.

Sådan afkalker du	
Afkalkningsmiddel	De'Longhi afkalkningsmiddel
Beholder	Kapacitet 2 liter
Tid	~40min

1. (HVIS DE FINDES, FJERN BLØDGØRINGSFILTER OG SOFTBALLS). Hæld afkalkningsmiddel i vandtanken (A14) op til niveau **A** (svarende til en 100 ml pakke) markeret på indersiden af tanken (fig. 42).

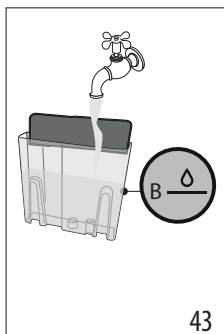
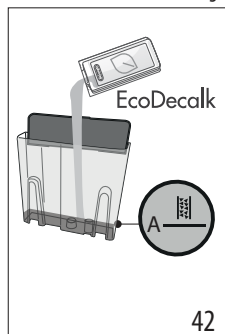

2. Tilsæt vand op til niveauet **B** (fig. 43). Sæt derefter vandtanken tilbage i maskinen.

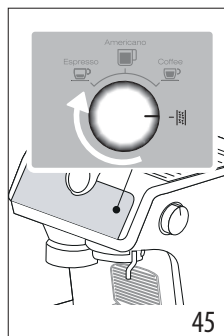
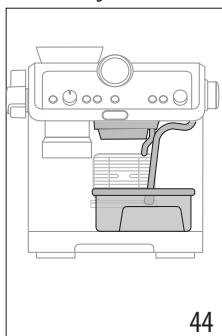

3. Sørg for, at filterholderen (C1) ikke er hæftet på, og anbring en beholder under kaffe- og varmtvandsudløbene og under dampdysen (A6) (fig. 44).
4. Drej justeringknappen (B8) hen på  (fig. 45): kontrollampen OK tændes med en orange farve; kontrollampen OK blinker.
5. Tryk på knappen OK: kontrollampen OK blinker.
6. Afkalkningsprogrammet starter, og afkalkningsvæsken kommer ud af tudene. Afkalkningsprogrammet udfører automatisk en række skylninger med mellemrum, for at fjerne kalkaflejringer inde i kaffemaskinen indtil tanken er fuldstændigt tømt. Brygningen afbrydes og kontrollampen OK bliver hvid. Det er nu nødvendigt at fortsætte med en skylningscyklus:
7. Tøm beholderen der er brugt til at opsamle afkalkningsmidlet og sæt den under udlejerne.
8. Tag vandbeholderen ud, tøm den for eventuelle rester af afkalkningsmiddel, skyl den med rindende vand og fyld den med rent vand op til MAX niveau (fig. 46). Sæt beholderen på plads.

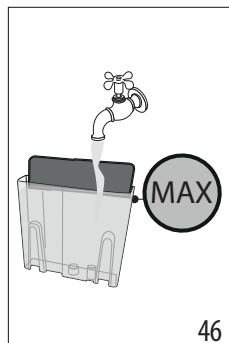











9. Tryk på knappen OK: skylningen sættes i gang.
10. Når skylningen er udført afbrydes udløbet og maskinen er klar til brug.
11. Tøm beholderen med det opsamlede skyllevand.



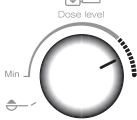

12. Tag drypbakken ud og tøm den for skyllevand.
 13. Tag beholderen ud og fyld den med rent vand og sæt den tilbage.
 Nu er maskinen klar til brug.

Bemærk venligst:







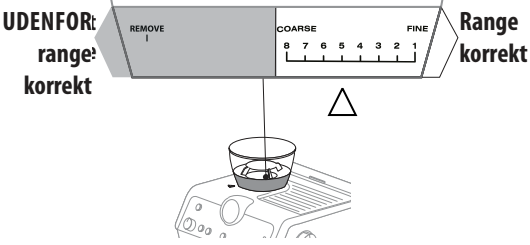



- Afkalkningscyklussen kan startes når som helst (selvom kontrollampen endnu ikke er tændt).
- Hvis afkalkningen er startet ved en fejltagelse, trykkes på knappen OK i 10 sekunder; skylning kan ikke afbrydes.

12. KONTROLLAMPERNES BETYDNING



KONTROLLAMPER	KONTROLLAMPERNES BETYDNING	DRIFT
Alle kontrollamperne blinker kort	Tænding af apparatet	Selvdiagnose
 lyser fast	Det er første gang maskinen anvendes og det er nødvendigt at fylde vandkredsløbet	Fortsæt som angivet i kap. "3. Første anvendelse af maskinen"
 Lyser fast (hvid) <ul style="list-style-type: none"> • Kontrollampen  : angiver den valgte kaffetemperatur • Kontrollampen  : angiver, at maskinen er klar til udledning af varmt vand 	Maskinen er klar til brygning	Gør maskinen klar og fortsæt med at tilberede drikken
 lyser fast	Energisparefunktionen er aktiv	Se kap. "7. Menu indstillinger" hvis man vil deaktivere funktionen
 lyser fast	Kaffebønnebeholder (A2) er tom	Fyld kaffebønnebeholder
 blinker	Man ønsker at formale, men bønnebeholderen (A2) er tom	Fyld kaffebønnebeholder
 Blinker kort med regelmæssigt interval	Justeringsknappen (B2) er drejet hen på positionen maksimal justering 	Når kaffen i filteret efter formalingen ikke er tilstrækkelig, vælges et nyt formalings range som angivet i kapitlet "7. Menu indstillinger".
 lyser fast	Der er ikke nok vand (A14) i beholderen eller vandbeholderen er ikke ordentligt sat i	Fyld beholderen eller tag den ud og sæt den i korrekt
→		

KONTROLLAMPER	KONTROLLAMPERNES BETYDNING	DRIFT
 blinker	Man ønsker at tilberede en drik, men vandbeholderen (A14) er tom	Fyld vandbeholderen op
	Malegraden er for fin, og kaffen løber for langsomt eller slet ikke ud	Tag filterholderen ud (C1), gentag handlingen for at lave kaffe imens man husker på anvisningerne i afsn. "4.1 Fase 1 - Formaling" og "4.2 Fase 2 - Stampning"
	Kaffefilteret (C2) eller (C3) er stoppet	Skyl filtrene under rindende vand
	Tanken (A14) er isat forkert, og dens ventiler er ikke åbne	Tryk let på tanken for at åbne ventilerne
	Kalk inden i det hydrauliske kredsløb	Udfør en afkalkning som angivet i kap. "11. Afkalkning"
 lyser fast	Maskinen er klar til at udlede damp	Maskinen er nået temperaturen til at udlede damp. For at fortsætte med brygningen skal dampknappen drejes (A4)
 blinker	Maskinen er tændt og energisparefunktionen er aktiv: dampknappen (A4) er i position til at udlede damp	Kontrollampen blinker for at advare om at den er på vej til at udlede damp: udledningen begynder så snart maskinen har den rette temperatur
	Maskinen er klar til at udlede damp	Maskinen har den rette temperatur til forberedelse af damp når kontrollampen forbliver tændt
	Maskinen udleder damp	
 lyser fast	Bønnebeholderen er ikke sat i	Sæt bønnebeholderen i korrekt (A2) eller kontroller at den er korrekt isat. Beholderen er indsat korrekt, når pilen ▲ er justeret med symbolet ☒, og der høres et "klik"
 blinker	Indstillingen af malegradsvælgeren er ikke korrekt eller overgår den maksimalt mulige indstilling	Sæt vælgeren i en af malepositionerne (mellem 1 og 8), og husk på: <ul style="list-style-type: none"> • Juster formalingen mens kværnen kører • Juster et niveau ad gangen, og lav mindst 5 malinger mellem den ene indstilling og den næste
	<div style="display: flex; align-items: center; justify-content: center;"> <div style="text-align: center; margin-right: 10px;"> <p>UDENFOR: range korrekt</p> </div>  <div style="text-align: center; margin-left: 10px;"> <p>Range korrekt</p> </div> </div>	



KONTROLLAMPER	KONTROLLAMPERNES BETYDNING	DRIFT
 lyser fast	Maskinen kræver stampning	Der er foretaget en formaling og filterholderen er sat på kaffekværnen
	Filterholderen er taget af kaffekværnen uden af blive presset	Tag filterholderen af og stamp kaffen som beskrevet i afs. "Den "perfekte dosis"" "Hvis der bruges formalet kaffe:"
	Filterholderen er hængt af uden at færdiggøre formaling, eller stampning er udført for tidligt	Gentag formalingen
	Tragten på kaffekværnen er stoppet	Udfør rengøring som beskrevet i afs. "8.5 Rengøring af "Smart tamping station"". Hvis problemet fortsætter, skal du åbne tragten ved at åbne lugen og frigøre den med børsten
	Kværnene er blokerede af et fremmedlegeme	Fjern fremmedlegemet og rens kværnene som beskrevet i afsn. "8.3 Rengøring af kaffekværnene".
 Lyser fast (rødt)	Det er nødvendigt at udføre afkalkning	Udfør en afkalkning som angivet i kap. "11. Afkalkning"
 blinker (rødt) +  blinker (orange)	Maskinen udfører afkalkning	Fortsæt med at afslutte handlingen som beskrevet i kap. "11. Afkalkning"
 blinker (rødt) +  Lyser fast (hvidt)	Det er nødvendigt at foretage en skylning	
 blinker (rødt) +  blinker (hvidt)	Maskinen er i gang med afkalkningscyklussen	
 lyser fast (orange)	Det er nødvendigt at udføre en rengøring af kaffebryggeren	Se afs. "8.1 Rengøring af kaffebryggeren"
 blinker (orange)	Maskinen er i gang med at udføre rengøring af kaffebryggeren	
Alle kontrollamper blinker	General alarm	Ret henvendelse til servicecenter

13. HVIS NOGET IKKE VIRKER

PROBLEM	ÅRSAG	LØSNING
Der er vand i drypbakken (A10)	Det er en del af normal drift af maskinens interne kredsløb	Tøm og rengør drypbakken regelmæssigt
Der løber ikke længere espressokaffe ud	Der mangler vand i vandbeholderen (A14)	Fyld vandbeholderen op
	Kontrollampen  (B6) er tændt for at angive, at kaffe- eller dampkredsløbet er tomt	Tryk på knappen ud for kontrollampen  for at fylde kredsløbet
	Filteret (C2) eller (C3) er tilstoppet	Skyl filtrerne under rindende vand
	Vandbeholderen (A14) sidder ikke rigtigt, og ventilerne på dens bund er ikke åbne	Tryk let på vandbeholderen for at åbne ventilerne på dens bund
	Kalk inden i det hydrauliske kredsløb	Udfør en afkalkning som angivet i kap. "11. Afkalkning"
	Formaling er alt for fin	Tag filterholderen ud (C1), gentag handlingen for at lave kaffe imens man husker på anvisningerne i afsn. "4.1 Fase 1 - Formaling" og "4.2 Fase 2 - Stampning"
Filterholderen er ikke hægtet på maskinen	Den formalede kaffe er ikke blevet presset eller forefindes i overdreven mængde	Gentag formalingen med andre indstillinger. Reducer dosismængden: Kontroller, at filteret (C2) eller (C3) (1 eller 2 kopper) er korrekt for den dosis, der skal males (2x knap (B3) valgt eller ikke)
Espressokaffen siver ud over filterholderens kanter (C1) i stedet for gennem hullerne	Filterholderen sidder ikke rigtigt	Hægt filterholderen korrekt på og drej den til bunds med bestemthed
	Kaffebryggerens pakning (A18) har tabt elasticiteten eller er beskidt	Udskift pakningen på kaffebryggeren hos et service center
	Filteret (C2) eller (C3) er tilstoppet	Skyl filtrerne under rindende vand
Kaffecremen er lys (espressokaffen løber hurtigt ud af kaffestudsden)	Det er nødvendigt at gennemgå maskinens indstillinger	Tag filterholderen ud, gentag handlingen for at lave kaffe imens man tager anvisningerne i afsn. "4.1 Fase 1 - Formaling" og "4.2 Fase 2 - Stampning"
Kaffecremen er mørk (espressokaffen løber for langsomt ud af kaffestudsden)	Det er nødvendigt at gennemgå maskinens indstillinger	Tag filterholderen ud (C1), gentag handlingen for at lave kaffe imens man husker på anvisningerne i afsn. "4.1 Fase 1 - Formaling" og "4.2 Fase 2 - Stampning"
Efter afkalkningscyklussens afslutning anmoder maskinen om en yderligere skylning	Under skyllecyklussen er beholderen ikke blevet fyldt til niveauet MAX	Gentag skylningen (se kap. "11. Afkalkning")
→		

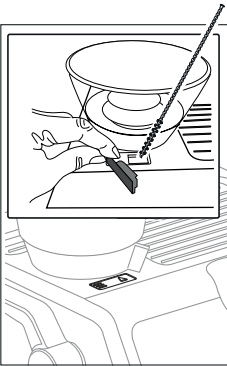
PROBLEM	ÅRSAG	LØSNING
Maskinen formaler ikke kaffen	Der er et fremmedlegeme tilstede internt i kaffekværnen	Udfør rengøring som beskrevet i afsn. "8.3 Rengøring af kaffekværnene", sørg for at have fjernet alle kaffebønner fra beholderen (A2) inden den tages af. Inden kværnen genindsættes skal lejet støvsuges for enhver rest
Hvis man ønsker at skifte kvaliteten af kaffen	Er det nødvendigt at fjerne alle eksisterende kaffebønner i maskinen	Beholderen er indsat korrekt, når pilen ▲ er justeret med symbolet ☒, og der høres et "klik" <ul style="list-style-type: none"> • Tøm kaffebønne beholderen (A2) (ved at udføre nogle formalinger uden kaffebønner eller ved eventuelt at støvsuge resterende bønner op) • Sæt filterholderen (C1) på og lav en "tom" formaling for at frigøre kaffekanalene: sæt filterholderen på hanen til formalet kaffe (A19) ved at centre den med teksten INSERT og dreje holderen mod venstre. Formalingen begynder når filterholderen står på CLOSE og den stopper automatisk. Gentag indtil filteret er tomt • Sæt det nye sortiment af kaffebønner i beholderen (A2) • Hvis den "perfekte dosis" ikke nås under formaling, fortsættes som ved første brug
Efter formaling er kaffefilteret (C2) eller (C3) tomt Efter formalingen er der for meget kaffepulver i filtret	Tragten på kaffekværnen er stoppet	Udfør rengøring som beskrevet i afs. "8.5 Rengøring af "Smart tamping station"". Hvis problemet fortsætter, skal du åbne renden ved at åbne lugen (A21) og frigøre den med børsten <div style="text-align: center; margin-top: 10px;">  </div>
→		

PROBLEM	ÅRSAG	LØSNING
Efter formaling når kaffepulveret i filteret (C2) eller (C3) når ikke den "perfekte dosis"	"Smart Tamping Station" skal rengøres	Udfør rengøring som beskrevet i afs. "8.5 Rengøring af "Smart tamping station", gentag derfor formalingen
	Det er nødvendigt at øge mængden af formalet kaffe	Regulér mængden med den særlige knap (B2) ved at følge anvisninger i afsn. "Den "perfekte dosis"". Hvis knappen allerede er i maks. position fortsættes som angivet i afsnittet "7. Menu indstillinger" - "Ekstra regulering af formaling"
	Kværnene slides med tiden	Udfør udskiftning af kværnene som beskrevet i afsn. "8.4 Udskiftning af kaffekværnene"

Lue aina turvallisuusohjeet sisältävä asiakirja ennen laitteen käyttöä.

1. KUVAAUS

1.1 Laitteen kuvaus - A

- A1. Kahvipapusailiön kansi
- A2. Kahvipapusailiö
- A3. Kuppialusta
- A4. Höyrynuppi
- A5. Kuumavesisuutin
- A6. Höyryn annosteluputki
- A7. Espresso-kuppiritilä
- A8. Kuppiritilä laseille tai mukeille
- A9. Alustan ritilä
- A10. Tippa-alusta
- A11. Tippa-alustan veden tason ilmaisin
- A12. Vesisäiliön kansi
- A13. Vesisäiliön irrotuskahva
- A14. Vesisäiliö
- A15. Pehmennysuodattimen paikka
- A16. Virtajohdon liittimen paikka
- A17. Virtakatkaisin (ON/OFF)
- A18. Kahvisuutin
- A19. Kahvimyllyn ulostulokohta (Tamping station)
- A20. Tamperin vipu
- A21. Luukku kahvimyllyn kahvikourua varten

1.2 Ohjauspaneelin kuvaus - B

- B1. ON/Standby-näppäin
- B2. Jauhetun kahvin määrän säätönuppi
- B3. Näppäin "X2": 2 kahvin suodattimen käyttämiseksi
- B4. Kahvin lämpötilan näppäin
- B5. "OK"-näppäin: juoman annostelu/vahvistus
- B6. Kuumen veden annostelunäppäin
- B7. "My"-näppäin: juomien määrän muokkaus
- B8. Toimintojen valintanuppi
 - Espresso
 - Americano
 - Coffee
 - Kalkinpoisto
- B9. Kalkinpoiston merkkivalo
- B10. Höyry valmis -merkkivalo
- B11. Kahvipapusailiön puuttumisen merkkivalo
- B12. Energiansäästön merkkivalo
- B13. Puhdistuksen merkkivalo (katso "8.1 Kahvisuuttimen puhdistus")
- B14. Tyhjän kahvipapusailiön merkkivalo
- B15. Veden puuttumisen merkkivalo
- B16. Tappauksen merkkivalo
- B17. Painemittari

1.3 Varusteiden kuvaus - C

- C1. Suodatinkuppipidike
- C2. 1 kupin suodatin
- C3. 2 kupin suodatin
- C4. "Total Hardness Test" -reagenssiliuska
- C5. Kalkinpoistoaine
- C6. Irrotettava virtajohto
- C7. Puhdistusharja
- C8. Kahvisuuttimen puhdistusväline
- C9. Softballs
- C10. Maitokannu
- C11. Höyrysuuttimen puhdistusneula

1.4 Valmistajan suosittelemat puhdistusvarusteet, jotka eivät kuulu toimitukseen

Lue lisäohjeet  Delonghi.com.

Puhdistustabletit

(Katso "8.1 Kahvisuuttimen puhdistus")

Puhdistusaine

EAN: 800439933307

2. KEITTIMEN VALMISTELU

Pese kaikki lisävarusteet haalealla vedellä ja astianpesuaineella ja toimi sitten seuraavasti:

1. Laita kahvipapusailiö (A2) kahvimyllyyn (kuva 1). Säiliö on asetettava oikeaoppisesti, kun nuoli ▲ on kohdistettuna symboliin  ja kuuluu klik-ääni (kuva 2).
2. Laita tippa-alusta (A10), jossa on kuppiritilä (A8) ja alustan ritilä (A9) (kuva 3).
3. Irrota vesisäiliö (A14) (kuva 4) ja täytä se riittävästi puhdalla vedellä. Ole tarkkana, ettei MAX-kirjoitus ylitä (kuva 5).
4. Laita säiliö sitten takaisin paikoilleen.

Varoitus: *Keitintä ei saa koskaan käynnistää, ellei säiliössä ole vettä tai ellei säiliö ole paikoillaan.*

Tärkeää: *Säädä veden kovuus mahdollisimman pian noudattamalla ohjeita, jotka on annettu luvussa "7. Asetusten valikko".*

3. ENNEN KEITTIMEN KÄYTTÖÖNOTTOA

1. Aseta virtajohdon liitin (C6) paikoilleen (A16) keittimen taakse (kuva 6). Laita sitten pistoke pistorasiaan. Varmista, että laitteen takaosassa oleva virtakatkaisin (A17) on painettu asentoon I (kuva 7).
2. Laita kuumavesisuuttimen alle (kahvisuuttimen kohdalle (A18)) astia, jonka tilavuus on vähintään 100 ml (kuva 8).
3. Paina näppäintä (B6) merkkivalon  (kuva 9) kohdalla: annostelu alkaa ja päättyy automaattisesti. Tyhjennä astia. Ennen kuin keitintä aletaan käyttää, sen sisäpiirit on huuhdeltava. Toimi seuraavasti:

- Kiinnitä suodattimella varustettu suodatinkuppipidikke (C1) keittimeen: sen oikeaan kiinnittymistä varten aseta suodatinkuppipidikkeen kahva kohdakkain symbolin "INSERT" kanssa (kuva 10) ja käännä kahvaa oikealle, kunnes se asetuu "CLOSE"-kohtaan;
- Laita astia suodatinpidikkeen ja höyrysuuttimen alle (A6).
- Paina OK-näppäintä (B5) (kuva 11): annostelu alkaa.
- Kun annostelu on päättynyt, käännä höyrynuppia (A4) (kuva 12) ja annostele höyryä muutaman sekunnin ajan höyrypiiriin huuhtelemiseksi: parasta höyryannostelua varten suosituksena on toistaa tämä toimenpide 3–4 kertaa. Näin putkessa oleva vesi voidaan poistaa ennen höyryn annostelua.

Näin keitin on käyttövalmis.

Tärkeää: *Sisäisten piirien huuhdeltua suositellaan tehtäväksi myös silloin, kun keittintä ei käytetä pitkään aikaan.*

Ensimmäisellä käyttökerralla tulee valmistaa 4–5 kahvia ennen kuin keittimen valmistama kahvi on hyvää. Kiinnitä huomiota erityisesti: suodattimessa olevaan kahvijauheen määrään ((C2) tai (C3)) (katso ohjeet kappaleesta "4.1 1. vaihe - Jauhatus (grinding)").

Toimi noudattamalla ohjeita luvusta "Täydellinen annos".

4. KAHVIN VALMISTUS

4.1 1. vaihe - Jauhatus (grinding)

- Lisää pavut säiliöön (A2) (kuva 13). Suosituksena on, että kahvipapuja lisätään ainoastaan valmistuksessa tarvittava määrä: näin kahvi on aina tuoretta.
- Valitse jauhatuskarkeus (kuva 14). Oletusasetuksena on 5 (keskihieno jauhatus). Jos tulos ei tyydytä, säädä tasoa oman makusi ja kahvityypin mukaan (säätö tulee tehdä kahvimyllyn toimiessa).

Tärkeää: *Jauhatuskarkeutta välillä 3–6 suositellaan useimmille kahveille. Valinnan ollessa 1 tai 2 jauhatuskarkeus on hyvin hieno, ja sitä tulee käyttää vain erityiskahvin tapauksessa (kevyt paahoto).*

- Laita yksi kahvisuodattimista (C2) tai (C3) suodatinpidikkeeseen (C1) (kuva 15). Jos käytät 2 kupin suodatinta, paina näppäintä X2 (B3): kun tämä on valittuna, myös annostellun espresson määrä kaksinkertaistuu.
- Säädä määrän nuppia (B2) minimiasennosta alkaen (kuva 16).

Katso lisätietoja kappaleesta "Säädä kahvijauheen määrää suodattimessa".

- Kiinnitä suodatinpidike kahvimyllyn ulostulokohtaan (A19) ja kohdistaa se INSERT-tekstiin: käännä kuppia sitten oikealle. Jauhatus alkaa, kun kuppi saavuttaa CLOSE-asennon, ja keskeytyy automaattisesti.

Säädä kahvijauheen määrää suodattimessa

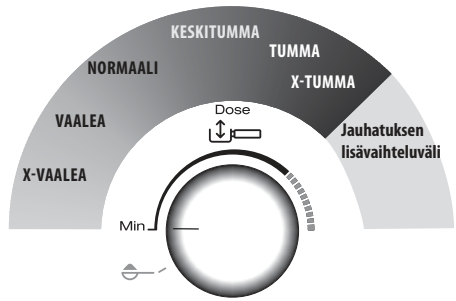

Jokainen kahvipapulaji antaa eri jauhatustuloksen, joten annoksen säätö tulee tehdä tarkoin alussa.

Tässä kuvassa näytetään, miten annos säädetään paahotvärin perusteella: tiedot ovat suuntaa antavia ja voivat vaihdella kahvipapujen koostumuksen perusteella.

- Aseta annos minimiasennosta.
- Käännä nuppia hitaasti kahvin paahotvärin perusteella.

4.2 2. vaihe - Tamppaus (tamping)

- Kun jauhatus on valmis, laske tamppausvipu (A20) loppuun asti (älä irrota suodatinpidikettä) (kuva 17). Täydellistä tulosta varten toista 2 kertaa.
- Pidä vipua painettuna loppuasennossa suodatinpidikkeen irrotuksen ajan (kuva 18). Tuo vipu sitten alkuasentoon.
- Kun on tarkistettu, että kahviannos on oikein (katso "Täydellinen annos"), liitä suodatinpidike kahvisuuttimeen (A18) (kuva 19).

Tärkeää: *Jos kahvia jää suodattimen sivuille tamppauksen aikana, uuttamislaatu ja näin ollen lopputulos ei kuitenkaan heikkene.*

Täydellinen annos

- Kahvisuodattimilla on sisäinen merkintä ihanteellisen annoksen tunnistamiseksi.

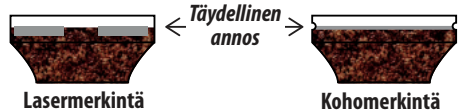

- Lasermerkinnällä varustetut suodattimet: täydellinen annos vastaa merkinnän ylintä viivaa;
- Kohomerkinnällä varustetut suodattimet: täydellinen annos vastaa koholla olevaa viivaa;
- Varmista, että kahvi on tasaisesti tamppauksen jälkeen. Nuppia (B2) saatetaan joutua säätämään monta kertaa ennen kuin annos on täydellinen.
- Jos kahvi on yli- tai aliuuttunut ja annos on täydellisen annoksen mukainen, säädä jauhatuskarkeus hienommaksi tai karkeammaksi (katso "4.1 1. vaihe - Jauhatus (grinding)"). Jos kahvi on yliuuttunut (annostelu liian hidasta), jauhatus-

sen tulee olla karkeampi. Jos kahvi on aliuuttunut (annostelu liian nopea), jauhatuksen tulee olla hienempi.

- **Baristan vinkit:** Irrota suodatinpidike tamppausvivun (A20) ollessa laskettuna, jotta kahviannoksen viimeistely onnistuisi.
- **Jos käytetään esijauhettua kahvia:**
 - lisää esijauhettua kahvia suodatimeen
 - käännä nuppi asentoon 
 - kiinnitä suodatinpidike kahvimyllyn ulostulokohtaan
 - laske tamppausvipu.













4.3 3. vaihe - Annostelu (brewing)

1. Valitse lämpötila (kuva 20) (katso ”Kahvin valmistuksen lämpötila”).
2. Valitse haluamasi juoma (kuva 21).
3. Paina OK (B5) annostelun aloittamiseksi (kuva 11) (esiuttaminen ja uuttaminen). Kahvin annostelu alkaa ja keskeytyy automaattisesti.

Kahvin valmistuksen lämpötila

Veden lämpötilaa hallinnoidaan koko valmistusvaiheen aikana tasaisuuden takaamiseksi annosteluvaiheessa. Specialista Prestigio tarjoaa 3 uuttamislämpötilaa*, jotka vastaavat vaihteluväliä 92–96°C.

Populajikkeen ja paahtoasteen perusteella suositellaan eri lämpötilaa: Robusta-pavut edellyttävät alhaista lämpötilaa, ja Arabica-pavut edellyttävät korkeaa lämpötilaa. Sama pätee tummapaahtoisiin papuihin tai juuri paahdettuihin papuihin.

Lämpötilan taso	Vastaava merkkivalo	Paahtoaste
MIN.	   	Tumma
NORM.	   	Keskitumma
MAKS.	   	Vaalea - Keskitumma

* Tämä lämpötila koskee thermoblockissa olevaa vettä. Se poikkeaa kupissa olevan juoman lämpötilasta tai lämpötilasta, joka mitataan, kun juoma tulee ulos suodatinpidikkeen suuttimesta.

5. MAITUJUOMIEN VALMISTUS

5.1 Vaahdota maito

1. Lisää kannuun (C10) maito, jonka tahdot lämmitteä/ vaahdottaa. Ota huomioon, että maidon tilavuus 2- tai 3-kertaistuu (kuva 22). Jotta vahto olisi tiiviimpää ja yhtenäisempää, suosituksena on käyttää täysmaitoa, joka on jääkaappikylmää (noin 5°C).

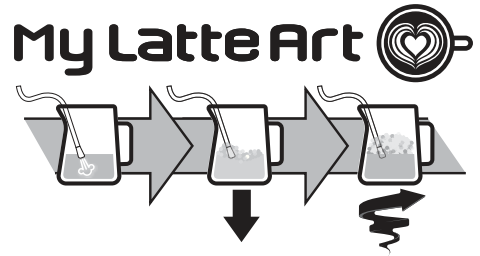

2. Maidon vaahdottamiseksi aseta höyryn annosteluputki (A6) maidon pintaan: näin ilma sekoittuu maitoon ja höyryyn.
3. Pidä höyrysuutin pinnassa. Ole tarkkana, ettei otta liikaa ilmaa, jolloin kuplat ovat liian suuria.
4. Upota höyrysuutin maidon pinnan alle. Näin syntyy pyörre. Kun haluttu lämpötila on saavutettu, sulje höyrynuppi uudelleen ja odota, että höyryn annostelu keskeytyy kokonaan ennen kuin otat maitokannun pois.

Baristan vinkit:

- **Tuore maito on parasta.** Käytä aina tuoretta ja jääkaappikylmää maitoa.
- Parempaa tulosta varten maitokannu kannattaa aina laittaa takaisin jääkaappiin.
- Täysmaito takaa erinomaiset tulokset. Vaahdon koostumus ja tulos riippuvat käytetystä lehmänmaidosta ja kasvijuomasta.
- Kun maito on vaahdotettu, poista kuplat pyörittämällä maitokannua kevyesti.

Höyrysuuttimen puhdistus:

1. Poista jokaisen käytön jälkeen liinalla maitojäämät höyrysuuttimesta (kuva 23). Perusteellista puhdistusta varten suositellaan Eco MultiClean -puhdistusaineen käyttöä. Se poistaa maidon proteiinit ja rasvat, ja sitä voidaan käyttää koko keittimen puhdistukseen.
2. Annostelee höyryä muutaman sekunnin ajan puhdistaaaksesi suuttimen kunnolla (kuva 12).
3. Odota, että suutin jäähtyy. Jotta sen tehokkuus säilyisi, käytä puhdistusneulaa (C11) 3 reiän vapaana pitämiseksi (kuva 24).

6. MUOKKAA KAHVIJUOMIEN PITUUTTA NÄPPÄIMESTÄ (my) (B7)

- Valmistele keitin annostelemaan 1 tai 2 kupillista kahvijuurua, jota tahdotaan annostella, kunnes kiinnitetään suodatinpidike, (C1) jossa on suodatin, (C2) tai (C3) kahvijauhetta.
- Käänä nuppia (B8) valitaksesi ohjelmoitavan juoman.
- Paina näppäintä (my): näppäintä (my) vastaava merkkivalo vilkkuu.
- Paina OK-näppäintä annostelun aloittamiseksi. Merkkivalot, jotka vastaavat näppäimiä OK ja (my), vilkkuvat.
- Kun määrä on sopiva, paina OK. Jos juomaan kuuluu jonkin muun ainesosan annostelu, tämän annostelu alkaa. Kun haluttu määrä on saavutettu, paina OK.
- Paina näppäintä (my) tallentaaksesi. Keitin on valmis uuteen käyttöön, ja merkkivalo (my) palaa.

Jos ohjelmointia ei haluta tallentaa, paina mitä tahansa muuta näppäintä.

Tärkeää:

- Kahvijuomat voidaan ohjelmoida, mutta ei höyryn ja kuumien veden annostelua.
- Ohjelmointi muokkaa juomamääriä, mutta ei jauhetun kahvin määrää.
- Juomat "X2" voidaan ohjelmoida erikseen.
- Tehdasasetuksiin palaamiseksi pidä painettuna näppäintä (my) sammumiseen asti. Valittu juoma palaa oletusarvoon.



Kahvin ohje	Oletusarvoinen määrä	Ohjelmoitava määrä
 Espresso	35 ml	25–90 ml
 Espresso X2	70 ml	50–180 ml
 Coffee	80 ml	50–120 ml
 Coffee X2	160 ml	120–240 ml
 Americano	120 ml	<ul style="list-style-type: none"> espresso: 25–60 ml vesi: 25–120 ml
 Americano X2	240 ml	<ul style="list-style-type: none"> espresso: 50–120 ml vesi: 50–240 ml

7. ASETUSTEN VALIKKO

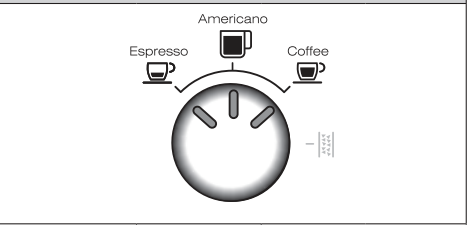

1. Siirry valikkoon:		
Pidä painettuna samanaikaisesti 5 sekunnin ajan	x2	(my)
→		

2. Asetukset nupista tehtävällä valinnalla (B8)



Vastaava asetus	Käänä kohtaan	Säädöt
Jauhatuksen lisäsäätö		x2 → Vaihteluväli 1
		☰ → Vaihteluväli 2
Veden kovuus		x2 → pehmeä
		☰ → puolikova
		OK → kova/hyvin kova
Automaattinen sammutus		x2 → 9 minuuttia
		☰ → 1,5 tuntia
		OK → 3 tuntia

3. Asetukset näppäimestä tehtävällä valinnalla:

Energian säästö	 → Päällä
	 →  Pois päältä
Oletusarvot	Pidä näppäintä (my) painettuna vähintään 5 sekunnin ajan niin kauan kuin merkkivalo palaa yhtäjaksoisesti

4. Tallenna uudet asetukset painamalla ON/Stand-by-näppäintä (B1)

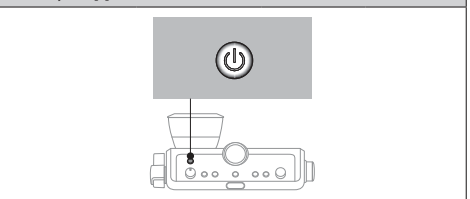

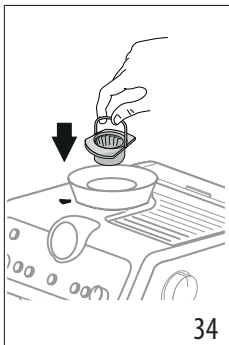
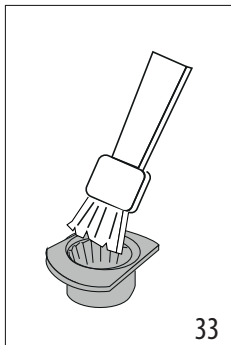

6. Laita mylly paikoilleen (kuva 34).
7. Käännä säädintä ja valitse haluamasi jauhatuskarkeus (kuva 14).

Tarkista, että mylly on kunnolla paikoillaan, vetämällä sitä kahvasta. Mylly on oikeaoppisesti paikoillaan, jos se ei liiku.

8.4 Myllyjen vaihto

Kun jauhettua kahvimäärä vähenee entisestään, käänny huoltokorjaamon puoleen myllyjen vaihtamiseksi. Säädä sitten uudelleen kahvimyllyä siirtymällä asetusvalikkoon ("7. Asetusten valikko") ja valitsemalla jauhatuksen ensimmäisen lisäsäädön vaihteluvälin. Käännä sitten määrän säätönappi (B2) MIN-asettoon ja säädä annosta samoin kuin ensimmäisellä käyttökerralla (katso "Täydellinen annos").

8.5 Puhdistus: "Smart tamping station"

1. Puhdista kiinnitysalue sudilla (kuva 35).
2. Vedä vipu (A20) loppuun asti ja puhdista tamperi (kuva 36) sudilla. Vapauta sitten vipu.
3. Puhdista kahvikouru puhdistusharjalla (C7)(kuva 37).

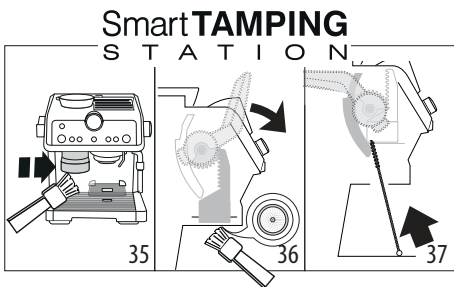

9. VEDEN KOVUUS

Kalkinpoiston merkkivalo (B9) syttyy ennalta määritetyn toiminta-ajan päätteeksi. Aika riippuu veden kovuudesta. Keitin voidaan ohjelmoida myös käyttämäsi veden kovuudelle, jolloin myös kalkinpoistoon liittyvistä toimenpiteistä tulee harvempia.

1. Ota varustuksiin kuuluva reagenssiliuska pois pakkauksesta "TOTAL HARDNESS TEST" (C4).
2. Upota se kokonaan vesilasiin noin sekunnin ajaksi.
3. Ota liuska vedestä ja ravista sitä kevyesti. Tee keittimen asetukset noudattamalla ohjeita luvusta "7. Asetusten valikko".

Veden kovuustestin tulos	Näppäin	Kovuusaste
	× 2	1 pehmeä vesi
		2 puolikova vesi
	OK	3 kova tai hyvin kova vesi

4. Tee keittimen asetukset noudattamalla ohjeita luvusta "7. Asetusten valikko".

10. SOFTBALLSIEN KÄYTTÖ

Softballs (C9) on innovatiivinen järjestelmä, joka pidentää keittimen käyttöikää veden laatua muuttamatta. Näin se takaa kerman ja aromaattisen kahvin. Tehokkuuden optimoimiseksi jätä Softballsit veteen kokonaiseksi yöksi ennen käyttöä.

1. Poista Softballs-paketti pakkauksesta (kuva 38).

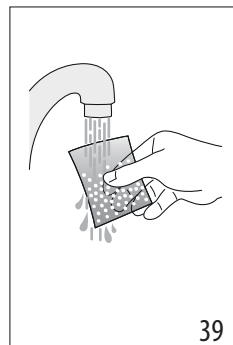
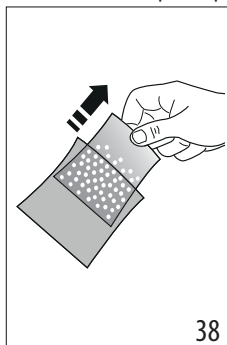

2. Huuhtelee Softballs-paketti juoksevilla vedellä (kuva 39).
3. Upota pussi vesisäiliöön (A14) (kuva 40).

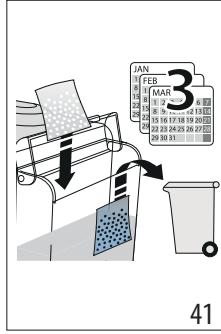
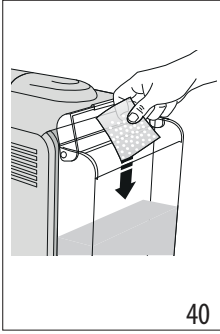

4. Vaihda Softballs-pussi 3 kuukauden välein (kuva 41).

11. KALKINPOISTO

Varoitus!

- Lue huolella kalkinpoistoaine valmistajan antamat käyttöohjeet ja merkinnät ennen käyttöä. (C5)Ne löytyvät kalkinpoistoaine pakkauksesta.
- Suosittelemme käyttämään ainoastaan De'Longhin kalkinpoistoainetta. Väärälaisten kalkinpoistoaineiden käyttäminen, tai jos kalkinpoistoa ei suoriteta, voi aiheuttaa vikoja, joita valmistajan takuu ei korvaa.
- Kalkinpoistoaine voi vaurioittaa herkkiä pintoja. Jos tuotetta läikkyi vahingossa, kuivaa heti.

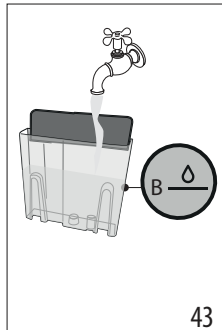
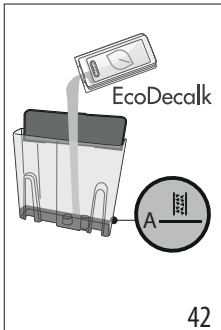

Kalkinpoiston ohjeet	
Kalkinpoistoaine	De'Longhi-kalkinpoistoaine
Astia	Tilavuus 2 litraa
Aika	~40min

1. (JOS ON, POISTA PEHMENNYSSUODATIN JA SOFTBALLS).
Lisää vesisäiliöön (A14) kalkinpoistoainetta tasoon  A asti (vastaa 100 ml:n pakkausta). Se on merkitty säiliön sisäpuolelle (kuva 42).

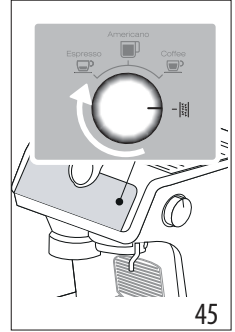
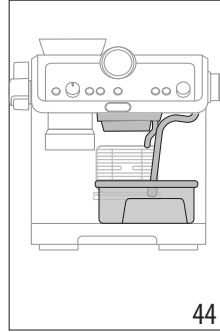

2. Lisää vettä tasoon  B (kuva 43) asti. Laita säiliö sitten takaisin keittimeen.



3. Varmista, että suodatinpidike (C1) ei ole kiinnitettyä ja aseta astia kahvi- ja kuumavesisuutinten alle ja höyrysuuttimen alle (A6) (kuva 44).
4. Käännä nappi (B8) asentoon  (kuva 45): OK-merkkivalo syttyy ja alkaa palaa oranssina; merkkivalo  vilkkuu.
5. Paina OK-näppäintä: merkkivalo OK vilkkuu.
6. Kalkinpoisto-ohjelma käynnistyy, ja kalkinpoistonestettä alkaa tulla ulos suuttimista. Kalkinpoisto-ohjelma suorittaa automaattisesti huuhtelujaksoarjan kahvinkeittimen sisällä olevan kalkkijäämän poistamiseksi, kunnes säiliö on tyhjä.

Annostelu keskeytyy, ja merkkivalosta OK tulee valkoinen. Huuhtelujakso on tarpeen:

7. Tyhjännä kalkinpoistoainenesteen talteenotossa käytetty astia ja aseta se suutinten alle.
8. Irrota vesisäiliö, tyhjännä se mahdollisista kalkinpoistoaineliuoksen jäämistä, huuhtele se juoksevassa vedessä ja täytä se raikkaalla vedellä MAX-tasoon asti (kuva 46). Laita säiliö sitten takaisin paikoilleen.

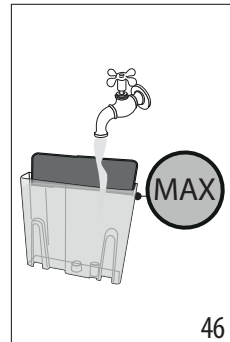









9. Paina OK-näppäintä: huuhtelu alkaa.
10. Kun huuhtelu on suoritettu, annostelu keskeytyy ja keitin on käyttövalmis.
11. Tyhjännä huuhteluveden keräysastian.





12. Irrota ja tyhjä tippa-alusta ja laita se sitten takaisin paikoilleen.
13. Irrota säiliö ja täytä se raikkaalla vedellä. Aseta takaisin paikoilleen.
- Nyt keitin on käyttövalmis.







Tärkeää:

- Kalkinpoistojakso voidaan käynnistää milloin tahansa (vaikka vastaava merkkivalo ei palaisikaan).
- Jos kalkinpoisto aloitettiin vahingossa, pidä OK-näppäintä painettuna 10 sekunnin ajan. Huuhtelua ei voida keskeyttää.

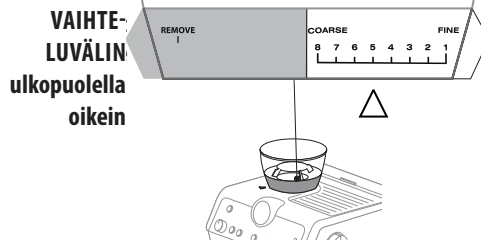
12. MERKKIVALOJEN SELITYKSET

MERKKIVALOT	MERKKIVALOJEN SELITYKSET	TOIMINTA
Kaikki merkkivalot vilkkuvat lyhyesti	Keittimen käynnistys	Itsemääritys
 palaa yhtäjaksoisesti	Keitin käynnistetään ensimmäistä kertaa, ja vesipiiri on täytettävä.	Etene noudattamalla ohjeita, jotka on annettu luvussa "3. Ennen keittimen käyttöönottoa"
 palaa yhtäjaksoisesti (valkoisena)	Keitin on valmis annostelemaan	Valmistelee keitin ja jatka juoman valmistukseen
<ul style="list-style-type: none"> Merkkivalo  osoittaa valitun kahvin lämpötilan Merkkivalo  : osoittaa, että keitin on valmis annostelemaan kuumaa vettä 		
 palaa yhtäjaksoisesti	Energiansäästötoiminto on päällä	Katso lukua "7. Asetusten valikko", jos tahdot ottaa toiminnon pois päältä
 palaa yhtäjaksoisesti	Kahvipapusaäiliö (A2) on tyhjä	Täytä kahvipapusaäiliö
 vilkkuva	Jauhatusta tahdotaan jatkaa, mutta kahvipapusaäiliö (A2) on tyhjä	Täytä kahvipapusaäiliö
 Vilkkuu lyhyesti tasaisin aikaväleihin	Nuppi (B2) on käännettynä animmäissäädön asentoon	Kun suodattimessa oleva kahvin määrä ei riitä jauhatuksen jälkeen, valitse uusi jauhatuksen vaihteluväli noudattamalla ohjeita luvusta "7. Asetusten valikko".
 palaa yhtäjaksoisesti	Säiliössä (A14) ei ole riittävästi vettä tai vesisäiliö ei ole kunnolla laitettuna	Täytä säiliö tai irrota säiliö ja laita se oikeaoppisesti jälleen paikoilleen
→		

MERKKIVALOT	MERKKIVALOJEN SELITYKSET	TOIMINTA
 vilkkuva	Juoman valmistusta tahdotaan jatkaa, mutta vesisäiliö (A14) on tyhjä	Täytä vesisäiliö
	Kahvi on liian hienoksi jauhettua, ja kahvi valuu tämän vuoksi liian hitaasti tai sitä ei tule ollenkaan.	Irrota suodatinkuppipidike (C1) ja toista kahvin valmistuksen toimenpiteet ottamalla huomioon ohjeet kappaleesta ”4.1.1. vaihe - Jauhatus (grinding)” ja ”4.2.2. vaihe - Tampaus (tamping)”
	Kahvinsuodatin (C2) tai (C3) on tukossa	Huuhtelee suodattimet juoksevan veden alla
	Säiliö (A14) on asetettu huonosti paikoilleen, eivätkä sen venttiilit ole auki	Paina säiliötä kevyesti niin, että sen venttiilit avautuvat
	Vesipiirissä on kalkkia	Suorita kalkkinpoisto noudattamalla ohjeita, jotka on annettu luvussa ”11. Kalkkinpoisto”
 palaa yhtäjaksoisesti	Keitin on valmis annostelemaan höyryä	Keitin on saavuttanut riittävän lämpötilan höyryn annostelua varten. Annostelun tekemiseksi käännä höyrynuppia (A4)
 vilkkuva	Keitin on päällä ja energiansäästötoiminto on päällä: höyrynuppi (A4) on asemassa höyryn annostelua varten	Merkkivalo vilkkuu osoittaen, että keitin valmistautuu höyryn annosteluun. Annostelu alkaa heti kun keitin on oikeassa lämpötilassa
	Keitin on valmis annostelemaan höyryä	Keittimen lämpötila on oikeaoppinen höyryn valmistukseen, kun merkkivalo palaa yhtäjaksoisesti
	Keitin annostelee höyryä	
 palaa yhtäjaksoisesti	Kahvipapusäiliö on ei ole paikoillaan	Laita kahvipapusäiliö (A2) kunnolla paikoilleen tai tarkista, että se on kunnolla paikoillaan. Säiliö on asetettuna oikeaoppisesti, kun nuoli ▲ on kohdistettuna symboliin 
		→

MERKKIVALOT	MERKKIVALOJEN SELITYKSET	TOIMINTA
 vilkkuva	<p>Jauhatuskarkeuden valitsinta ei ole säädetty oikein tai se ylittää suurimman sallitun asetuksen</p>	<p>Vie valitsin yhteen jauhatusasenoista (välillä 1–8) ja muista tehdä seuraavat toimenpiteet:</p> <ul style="list-style-type: none"> Säädi jauhatus kahvimyllyn toimiessa Säädi yksi taso kerrallaan ja tee vähintään 5 jauhatusa säätöjen välissä
	<p>VAIHTELUVÄLIN ulkopuolella oikein</p>  <p>Vaihteluväli oikein</p>	
 palaa yhtäjaksoisesti	<p>Keitin pyytää tamppausta</p>	<p>Jauhatus on juuri suoritettu, ja suodatinkuppi on kiinnitetty kahvimyllyyn</p>
	<p>Suodatinpidike on irrotettu kahvimyllystä tampperista</p>	<p>Irrota suodatinpidike ja jatka tamppaamalla kahvi noudattamalla ohjeita, jotka on kerrottu kappaleessa "Täydellinen annos" "Jos käytetään esijauhettua kahvia:"</p>
	<p>Suodatinpidike on irrotettu ennen jauhatus lopetusta tai tamppaus on tehty liian aikaisin</p>	<p>Toista jauhatus</p>
	<p>Kahvimyllyn kahvikouru on tukossa</p>	<p>Puhdista noudattamalla ohjeita, jotka on annettu kappaleessa "8.5 Puhdistus: "Smart tamping station"". Jos ongelma jatkuu, siirry kourun kohdalle avaamalla luukku ja vapauta se käyttämällä puhdistusharjaa</p>
	<p>Vieras esine on tukkinut myllyt</p>	<p>Poista vieras esine ja puhdista myllyt noudattamalla ohjeita kappaleesta "8.3 Myllyjen puhdistus".</p>
 palaa yhtäjaksoisesti (punaisena)	<p>Kalkinpoisto on tarpeen</p>	<p>Suorita kalkinpoisto noudattamalla ohjeita, jotka ovat luvussa "11. Kalkinpoisto"</p>
 vilkkuu (punainen) +  vilkkuu (oranssi)	<p>Keitin suorittaa kalkinpoistoa</p>	<p>Suorita toimenpide loppuun noudattamalla ohjeita, jotka on annettu luvussa "11. Kalkinpoisto"</p>
 vilkkuu (punainen) +  palaa yhtäjaksoisesti (valkoinen)	<p>Huuhtelu on tarpeen</p>	



MERKKIVALOT	MERKKIVALOJEN SELITYKSET	TOIMINTA
 vilkkuu (punainen) +  vilkkuu (valkoinen)	Keitin suorittaa kalkinpoistojakson huuhtelun	
 palaa yhtäjaksoisesti (oranssi)	Kahvisuuttimen puhdistus on tarpeen	Katso kappale ”8.1 Kahvisuuttimen puhdistus”
 vilkkuu (oranssi)	Keitin suorittaa kahvisuuttimen puhdistusta	
Kaikki merkkivalot vilkkuvat	Yleinen hälytys	Käännä huoltokorjaamon puoleen

13. JOS ON ONGELMIA

ONGELMA	SYY	RATKAISU
Tippa-alustassa (A10) on vettä	Tämä kuuluu keittimen sisäpiirin normaaliin toimintaan	Tyhjennä ja puhdista tippa-alusta säännöllisesti
Espressokahvia ei enää tule	Säiliössä ei ole vettä (A14)	Täytä säiliö
	Merkkivalo  (B6) palaa osoittaen, että kahvi- tai höyrypiiri on tyhjä	Paina näppäintä merkkivalon  kohdalla piirin täyttämiseksi
	Suodatin (C2) tai (C3) on tukossa	Huuhtele suodattimet juoksevan veden alla
	Säiliö (A14) on asetettu huonosti paikoilleen, eivätkö sen pohjassa olevat venttiilit ole auki	Paina säiliötä kevyesti niin, että sen pohjassa olevat venttiilit avautuvat.
	Vesipiirissä on kalkkia	Suorita kalkinpoisto noudattamalla ohjeita, jotka on annettu luvussa ”11. Kalkinpoisto”
	Liian hieno jauhatus	Irrota suodatinkuppipidike (C1) ja toista kahvin valmistuksen toimenpiteet ottamalla huomioon ohjeet kappaleesta ”4.1 1. vaihe - Jauhatus (grinding)” ja ”4.2 2. vaihe - Tamppaus (tamping)”
Suodatinkuppi ei kiinnity keittimeen	Jauhetta kahvia ei ole tampattu tai sitä on liikaa	Toista jauhatus eri asetuksilla. Vähennä annoksen määrää: tarkista, että suodatin (C2) tai (C3) (1 tai 2 kuppia) on oikea suhteessa jauhatettavaan annokseen (näppäin 2x (B3) valittuna vai ei)
Espresso valuu suodatinkupin reunoista (C1) eikä reitistä	Suodatinkuppi ei ole kunnolla paikoillaan	Kiinnitä suodatinkuppi oikeaoppisesti ja käännä se loppuun asti voimakkaasti
	Kahvisuuttimen tiiviste (A18) on löystynyt tai likaantunut	Vaihda kahvisuuttimen tiiviste valtuutetussa huoltokeskuksessa
	Suodatin (C2) tai (C3) on tukossa	Huuhtele suodattimet juoksevan veden alla

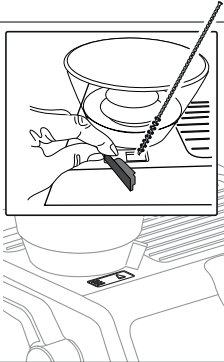

ONGELMA	SYY	RATKAISU
Kahvin vaahto on vaaleaa (valuu nopeasti suuttimesta)	Keittimen asetukset tulee tarkistaa	Irrota pidike ja toista kahvinvalmistus-toimenpiteet ottaen huomioon ohjeet kappaleesta "4.1 1. vaihe - Jauhatus (grinding)" ja "4.2 2. vaihe - Tamppaus (tamping)"
Kahvin vaahto on tummaa (valuu hitaasti suuttimesta)	Keittimen asetukset tulee tarkistaa	Irrota suodatinkuppipidike (C1) ja toista kahvin valmistuksen toimenpiteet ottaen huomioon ohjeet kappaleesta "4.1 1. vaihe - Jauhatus (grinding)" ja "4.2 2. vaihe - Tamppaus (tamping)"
Keitin pyytää toisen huuhtelun kalkinpoiston päätteeksi	Säiliötä ei ole täytetty MAX-tasoon asti huuhtelujakson aikana	Toista huuhtelu (katso luku "11. Kalkinpoisto")
Keitin ei jauha kahvia	Kahvimyllyn sisällä on vieras esine	Puhdista myllyt noudattamalla ohjeita, jotka on annettu kappaleessa "8.3 Myllyjen puhdistus". Varmista, että olet poistanut kaikki pavut kahvipapusaäiliöstä (A2) ennen sen poistoa. Ennen myllyn laittamista uudelleen paikoilleen imuroi kaikki jäämät sen kohdalta
	Kahvipapusaäiliö (A2) ei ole oikeaoppisessa asennossa	Säiliö on asetettuna oikeaoppisesti, kun nuoli ▲ on kohdistettuna symboliin ☒ ja kuuluu klik-ääni
Jos halutaan vaihtaa kahvilaatua	Kaikki keittimessä olevat pavut on poistettava	<ul style="list-style-type: none"> • Tyhjennä kahvipapusaäiliö (A2) (tekemällä tyhjäjauhatuksia tai imuroimalla jäljelle jääneet pavut). • Kiinnitä suodatinkuppipidike (C1) ja tee tyhjäjauhatuksia kahvikanan vapauttamiseksi. Kiinnitä sitten suodatinkuppipidike kahvimyllyn ulostulokohtaan (A19) ja kohdistaa se INSERT-kirjoitukseen. Käännä sitten pidikettä oikealle. Jauhatus alkaa, kun kuppi saavuttaa CLOSE-asennon, ja keskeytyy automaattisesti. Toista, kunnes suodatin on tyhjä • Laita säiliöön (A2) uusi kahvipaputyyppe • Jos jauhatusta ei saavuteta täydellistä annosta, toimi samoin kuin ensikäytön kohdalla
		→

ONGELMA	SYY	RATKAISU
<p>Jauhatuksen jälkeen kahvuodatin (C2) tai (C3) on tyhjä</p> <p>Suodattimessa on liikaa kahvijauhetta</p>	<p>Kahvimyllyn kahvikouru on tukossa</p>	<p>Puhdista noudattamalla ohjeita, jotka on annettu kappaleessa "8.5 Puhdistus: "Smart tamping station"". Jos ongelma jatkuu, siirry kourun kohdalle avaamalla luukku (A21) ja vapauta se käyttämällä puhdistusharjaa</p> 
<p>Jauhatuksen jälkeen suodattimessa on kahvijauhetta (C2) tai (C3) ei saavuta täydellistä annosta</p>	<p>"Smart Tamping Station" on puhdistettava</p> <p>Jauhetun kahvin määrää on säädettävä</p> <p>Myllyt kuluvat ajan myötä</p>	<p>Puhdista noudattamalla ohjeita, jotka on annettu kappaleessa "8.5 Puhdistus: "Smart tamping station"", ja toista sitten jauhatus</p> <p>Säädä määrää omasta nupista (B2) noudattamalla ohjeita kappaleesta "Täydellinen annos". Jos nuppi on jo max-asennossa, etene noudattamalla ohjeita osiosta "7. Asetusten valikko" - "Jauhatuksen lisäsäätö"</p> <p>Vaihda myllyt noudattamalla ohjeita kappaleesta "8.4 Myllyjen vaihto"</p>

Перед использованием прибора прочитайте предупреждения по технике безопасности.

1. ОПИСАНИЕ

1.1 Описание прибора — А

- A1. Крышка контейнера для зерен
- A2. Контейнер для зерен
- A3. Подставка для чашек
- A4. Рукоятка подачи пара
- A5. Узел подачи горячей воды
- A6. Трубка подачи пара
- A7. Решетка подставки для чашек для эспрессо
- A8. Решетка подставки для чашек для стаканов или кружек
- A9. Решетка поддона
- A10. Поддон для сбора капель
- A11. Индикатор уровня воды в поддоне для сбора капель
- A12. Крышка бачка для воды
- A13. Рукоятка извлечения бачка для воды
- A14. Бачок для воды
- A15. Местоположение фильтра смягчения воды
- A16. Гнездо разъема шнура питания
- A17. Главный выключатель (ON/OFF)
- A18. Узел подачи кофе
- A19. Выход кофемолки (Tamping station)
- A20. Рычаг придавливателя
- A21. Дверца доступа к желобу кофемолки

1.2 Описание контрольной панели - В

- B1. Кнопка ON/Standby
- B2. Рукоятка регулировки количества молотого кофе
- B3. Кнопка X2: использование фильтра 2 кофе
- B4. Кнопка «температура кофе»
- B5. Кнопка ОК: подача напитка/подтверждение
- B6. Кнопка подачи горячей воды
- B7. Кнопка Mu: индивидуальный подбор объема напитков
- B8. Ручка выбора функций
 - Espresso
 - Americano
 - Кофе
 - Удаление накипи
- B9. Индикатор удаления накипи
- B10. Индикатор готовности пара
- B11. Индикатор отсутствия контейнера для зерен
- B12. Индикатор режима энергосбережения
- B13. Индикатор очистки (см. «8.1 Очистка узла подачи кофе»)
- B14. Индикатор пустого контейнера для зерен
- B15. Индикатор отсутствия воды
- B16. Индикатор прессования
- B17. Манометр

1.3 Описание принадлежностей — С

- C1. Фильтродержатель
- C2. Фильтр 1 чашки
- C3. Фильтр 2 чашек
- C4. Индикаторная полоска Total Hardness Test
- C5. Средство для удаления накипи
- C6. Шнур питания съемный
- C7. Ершик
- C8. Приспособление для очистки узла подачи кофе
- C9. Softballs
- C10. Графин для молока
- C11. Игла очистки для наконечника пара

1.4 Не включенные приспособления для очистки, рекомендованные производителем

Дополнительные сведения см. на сайте Delonghi.com.



Таблетки для очистки

(см. «8.1 Очистка узла подачи кофе»)

 **Чистящее средство**
EAN: 8004399333307

2. ПОДГОТОВКА ПРИБОРА

Теплой водой и средством для посуды вымойте все приспособления и выполните следующее:

1. Установите контейнер для зерен (A2) в кофемолку (рис. 1). Контейнер установлен правильно, если стрелка ▲ выровнена с символом  и слышится щелчок (рис. 2).
2. Установите поддон для сбора капель (A10) в комплекте с решеткой подставки для чашек (A8) и с решеткой поддона (A9) (рис. 3).
3. Снимите бачок для воды (A14) (рис. 4) и наполните его свежей чистой водой, не превышая отметку MAX (рис. 5).
4. Установите на место бачок для воды.

Внимание! Не включайте прибор без воды в бачке или без самого бачка.

Примечание. Рекомендуется как можно быстрее отрегулировать жесткость воды путем выполнения процедуры, описанной в главе «7. Меню настроек».

3. ПЕРВОЕ ВКЛЮЧЕНИЕ ПРИБОРА

1. Установите разъем шнура питания (C6) в специальное гнездо (A16) сзади прибора (рис. 6), затем вставьте вилку в розетку. Убедитесь, что главный выключатель (A17), находящийся сзади прибора, нажат в положении I (рис. 7).
2. Поместите под узлом подачи горячей воды (рядом с узлом подачи кофе (A18)) емкость минимальным объемом 100 мл (рис. 8).

3. Нажмите кнопку (B6) рядом с индикатором  (рис. 9), подача начнется и остановится автоматически. Слейте емкость.

Перед началом пользования машиной необходимо промыть внутренние контуры. Выполните следующие действия:

4. Наденьте фильтродержатель (C1) вместе с фильтром на кофемашину. Чтобы правильно закрепить фильтродержатель, выровняйте его ручку с надписью «INSERT» (рис. 10) и поверните рукоятку вправо до выравнивания с позицией «CLOSE».
5. Поместите емкость под фильтродержателем и под трубкой подачи пара (A6).
6. Нажмите кнопку ОК (B5) (рис. 11), начнется подача.
7. Когда подача завершена, поверните рукоятку пара (A4) (рис. 12) и подайте пар в течение нескольких секунд, чтобы ополоснуть контур пара. Для оптимальной подачи пара рекомендуется повторить это действие 3 или 4 раза. Это позволит перед подачей пара удалить воду в трубке.

Теперь прибор готов к работе.

Примечание. Промывание внутренних контуров рекомендуется также после длительного простоя прибора.

При первом использовании для получения удовлетворительного результата необходимо приготовить 4–5 чашек кофе. Особое внимание обратите на дозу молотого кофе в фильтре ((C2) или (C3)) (см. инструкции в параграфе «4.1 Этап 1 - Помол (grinding)»).

Выполните действия, указанные в главе «Идеальное количество».

4. ПРИГОТОВЛЕНИЕ КОФЕ

4.1 Этап 1 - Помол (grinding)

1. Засыпьте зерна в контейнер (A2) (рис. 13). Рекомендуется засыпать только то количество зерен, которое требуется для приготовления. Таким образом кофе всегда будет использоваться свежим.
2. Выберите степень помола (рис. 14). Заводская настройка 5 (средний помол). Если результат неудовлетворительный, отрегулируйте уровень в зависимости от собственного вкуса и от типа кофе (регулировку следует выполнять во время работы кофемолки).

Примечание. Степень помола от 3 до 6 рекомендуется для большинства типов кофе. При выборе значения 1 или 2 помол очень мелкий, который используется только для особых типов кофе (слегка обжаренный).

3. Поместите один из фильтров кофе (C2) или (C3) в фильтродержатель (C1) (рис. 15). Если используется фильтр для 2 чашек, нажмите кнопку X2 (B3). Благодаря этому вдвое увеличится количество подаваемого эспрессо.

4. Отрегулируйте рукоятку количества (B2) начиная с минимального положения (рис. 16).

Обратитесь к параграфу «Регулировка количества молотого кофе в фильтре» за дополнительными указаниями.

5. Закрепите фильтродержатель на выходе кофемолки (A19), выровняв его относительно надписи INSERT, затем поверните фильтродержатель вправо. Помол начинается, когда держатель достигает положения CLOSE, и прекращается автоматически.

Регулировка количества молотого кофе в фильтре



Каждый сорт зерна дает различный результат во время помола, поэтому в начале следует выполнить тщательную регулировку количества.

На изображении даются инструкции по регулировке количества на основе цвета обжарки. Их можно рассматривать как исходные, но они могут отличаться в зависимости от состава кофейных зерен.

1. Настройте количество начиная с минимального положения.
2. Медленно вращайте рукоятку с учетом цвета обжарки ваших кофейных зерен.

4.2 Этап 2 - Прессование (tamping)

1. После помола опустите рычаг прижима (A20) до упора (не снимайте фильтродержатель) (рис. 17). Для получения отличного результата повторите 2 раза.
2. Во время снятия фильтродержателя удерживайте рычаг опущенным до упора (рис. 18). Затем приведите рычаг в исходное положение.
3. После того, как убедились, что количество кофе правильное (см. «Идеальное количество»), закрепите фильтродержатель на узле подачи кофе (A18) (рис. 19).

Примечание. Если после прессования по краям фильтра остается кофе, это никак не влияет на качество заварки и, следовательно, на конечный результат.

Идеальное количество

- Фильтры кофе внутри имеют маркировку для определения идеального количества.

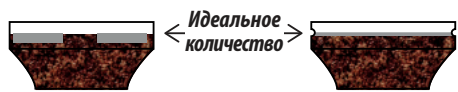

Лазерная маркировка

Рельефная маркировка

- Фильтры с лазерной маркировкой: идеальное количество соответствует верхней линии маркировки.
- Фильтры с рельефной маркировкой: идеальное количество соответствует линии выпуклости.
- Убедитесь, что кофе после прижима находится на уровне. Может потребоваться несколько раз регулировать рукоятку (B2) до получения идеального количества.
- Если кофе слишком экстрагирован или недоэкстрагирован, а количество находится в диапазоне идеального, отрегулируйте помол на более мелкий или более крупный (см. «4.1 Этап 1 - Помол (grinding)»). Если экстракция кофе повышена (слишком медленная подача), помол должен быть крупнее. Если экстракция кофе низкая (слишком быстрая подача), помол должен быть мельче.
- **Бариста рекомендует:** Доставьте фильтрдержатель, когда рычаг придавливания (A20) опущен, так получается отличный прижим дозы кофе.
- **Если используется предварительно молотый кофе:**
 - насыпьте предварительно молотый кофе в фильтр;
 - установите рукоятку на ☞;
 - закрепите фильтрдержатель на выходе кофемолки;
 - опустите рычаг прижима.

4.3 Этап 3 - Подача (brewing)

1. Выберите температуру (рис. 20, см. «Температура для приготовления кофе»).
2. Выберите желаемый напиток (рис. 21).
3. Нажмите ОК (B5) для начала подачи (рис. 11) (предварительная заварка и заварка). Подача кофе остановится автоматически.

Температура для приготовления кофе

Контроль за температурой воды осуществляется на протяжении всего процесса приготовления, чтобы обеспечить его стабильность на этапе экстракции. La Specialista Prestigio предлагает 3 уровня температуры заварки, которые соответствуют диапазону от 92° до 96 °С.

В зависимости от типа и степени обжарки зерен рекомендуется использование различных уровней температуры: зерна робусты требует более низкой температуры, а зерна арабики - более высокой. Те же требования действительны и для зерен темной обжарки или только что обжаренных зерен.

Уровень температуры	Соответствующий индикатор	Уровень обжарки
МИН.		темный
СРЕД		средне-темный
МАКС.		светло-темный

- * Эта температура относится к воде в термоблоке. Она отличается от температуры напитка в чашке или от температуры, замеренной когда напиток выходит из узлов подачи фильтрдержателя.

5. ПРИГОТОВЛЕНИЕ МОЛОЧНЫХ НАПИТКОВ

5.1 Вспенивание молока

1. Налейте в графин (C10) количество молока, которое вы хотите подогреть/вспенить. Следует помнить, что объем молока увеличится в 2 или в 3 раза (рис. 22). Для получения более плотной и однородной пены рекомендуется использовать цельное коровье молоко прохладной температуры (около 5 °С).

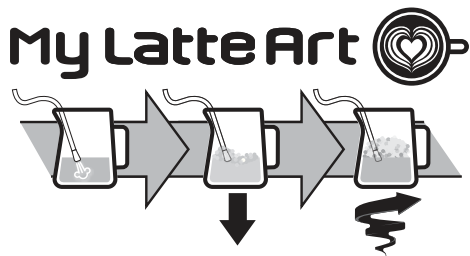

2. Для вспенивания молока опустите трубку подачи пара (A6) на поверхность молока, таким образом воздух смешается с молоком и паром.
3. Удерживайте узел подачи пара на поверхности и следите, чтобы не попадало слишком много воздуха, от этого возникают слишком большие пузыри.
4. Погрузите узел подачи пара ниже поверхности молока, таким образом создается воронка. Когда достигнута нужная температура, закройте рукоятку пара и дождитесь полной остановки подачи пара до того, как убрать графин молока.

Бариста рекомендует:

- **Лучше использовать прохладное молоко.** Всегда берите свежее молоко прохладной температуры.
- Чтобы получить наилучший результат, рекомендуется всегда держать графин с молоком в холодильнике.
- Цельное молоко обеспечивает отличный результат. Результат и текстура пены зависят от того, используется ли коровье молоко или растительные напитки.
- После вспенивания удалите пузыри из молока путем небольшого вращения по кругу графина с молоком.

Очистка узла подачи пара:

1. После каждого использования тряпкой удалите остатки молока с узла подачи пара (рис. 23). Для более тщательной очистки рекомендуется использовать Eco MultiClean. Средство обеспечивает гигиену, поскольку удаляет протеины и жиры молока. Его также можно использовать для очистки всей машины.
2. Подайте пар в течение нескольких секунд, чтобы хорошо очистить узел подачи (рис. 12).
3. Дождитесь охлаждения узла подачи. Для поддержания длительной исправности узла подачи используйте иглу для очистки (C11), чтобы держать свободными 3 отверстия (рис. 24).

6. ИНДИВИДУАЛЬНЫЙ ПОДБОР ОБЪЕМА КОФЕЙНЫХ НАПИТКОВ С ПОМОЩЬЮ КНОПКИ (my) (B7)

1. Подготовьте машину для подачи 1 или 2 чашек желаемого кофейного напитка вплоть до установки держателя (C1) с фильтром (C2) или (C3) и молотого кофе.
2. Поверните рукоятку (B8) для выбора напитка для программирования.
3. Нажмите кнопку (my): начнет мигать световой индикатор, соответствующий кнопке (my).
4. Нажмите кнопку ОК для начала подачи. Индикаторы кнопок ОК и (my) мигают.
5. После достижения необходимого количества нажмите ОК. Если напиток предусматривает подачу еще одного ингредиента, начинается его подача. После достижения необходимого количества нажмите ОК.
6. Нажмите кнопку (my) для сохранения. Прибор готов к новому использованию, индикатор (my) остается гореть. Если вы не хотите сохранить программирование, нажмите любую другую кнопку.

Примечание.



- Можно программировать кофейные напитки, но не подачу пара и горячей воды.

- Программирование изменяет количество напитков, а не количество молотого кофе.
- Напитки «X2» можно программировать по отдельности.
- Чтобы вернуться к заводским параметрам, **удерживайте нажатой кнопку (my) до выключения.** Выбранный напиток вернется к заводским параметрам.





Рецепт кофе	Заводское количество	Программируемое количество
 Espresso	35 мл	от 25 до 90 мл
 Espresso X2	70 мл	от 50 до 180 мл
 Coffee	80 мл	от 50 до 120 мл
 Coffee X2	160 мл	от 120 до 240 мл
 Americano	120 мл	• эспрессо: от 25 до 60 мл • вода: от 25 до 120 мл
 Americano X2	240 мл	• эспрессо: от 50 до 120 мл • вода: от 50 до 240 мл

7. МЕНЮ НАСТРОЕК

1. Вход в меню:		
нажимайте одновременно в течение 5 секунд	x2	(my)
2. Настройки, выбираемые рукояткой (B8)		
		
Соответствующая настройка	Повернуть на	Регулировки
Дополнительная регулировка помола	 Espresso	x2 → диапазон 1
		☰ → диапазон 2
→		

Жесткость воды	 Americano	×2 → мягкая
		☰ → средней жесткости
		○OK → жесткая/ очень жесткая
Автовывключение	 Coffee	×2 → 9 минут
		☰ → 1,5 часа
		○OK → 3 часа

3. Настройки, выбираемые кнопкой:

Экономия энергии	 → подключено
	 →  выключено
Заводские параметры	Удерживайте нажатой в течение 5 секунд кнопку  , пока индикатор не будет гореть ровным светом

4. Сохраните новые настройки нажатием ON/Standby (B1)

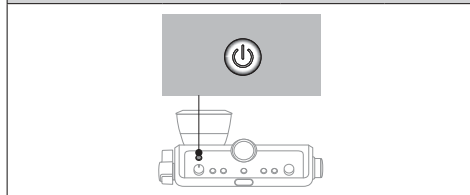

8. ОЧИСТКА ПРИБОРА











Внимание!

- Не используйте для чистки кофемашины растворители, абразивные моющие средства или спирт.
- Не используйте металлические предметы для удаления накипи или отложений кофе, поскольку они могут оцарапать металлические или пластмассовые поверхности.
- В случае простоев свыше одной недели перед повторным использованием машины рекомендуется выполнить ополаскивание.

Опасно!



- При очистке ни в коем случае не допускайте погружения машины в воду, это электрический прибор.

- Перед любой операцией по очистке внешних частей прибора выключите его, выньте вилку из розетки и дайте ему остыть.

					
	×	✓	✓	×	×
	✓	×	×	✓	✓
	×	×	×	✓	✓
	×	×	×	✓	✓
	×	×	✓	✓	×
	×	×	×	✓	✓

8.1 Очистка узла подачи кофе

Когда индикатор  загорается (оранжевый) (B13), необходимо выполнить очистку контура кофе. Для выполнения цикла очистки приобретите таблетки для очистки кофемашин. Более подробные сведения см. на веб-сайте www.Delonghi.com.

1. Установите фильтр 1 чашки (C2) в фильтродержатель (C1) (рис. 25).
2. Установите в фильтр приспособление для очистки (C8) (рис. 25) и нажмите до упора.
3. Положите таблетку для очистки на приспособление (рис. 26).
4. Закрепите фильтродержатель к узлу подачи кофе (A18).
5. Наполните бачок для воды (A14). Убедитесь, что поддон для сбора капель (A10) пуст.
6. Удерживайте нажатой кнопку  (B6), пока не загорится индикатор  (B13). Через несколько минут очистка автоматически остановится.
7. Снимите фильтродержатель и приспособление для очистки.
8. Вымойте фильтродержатель и фильтр под проточной водой.
9. Установите на место фильтродержатель и выполните ополаскивание нажатием кнопки  ; рекомендуется установить емкость под фильтродержателем.

10. Снимите и слейте поддон для сбора капель.

Примечание.

Этот цикл очистки можно запустить в любой момент нажатием кнопки  в течение нескольких секунд. Для отмены действия удерживайте кнопку 10 секунд.

8.2 Очистите место размещения контейнера для зерен

1. Убедитесь, что контейнер для зерен (A2) пуст. При необходимости выполните несколько пустых помолов для его полного опорожнения.
2. Отсоедините контейнер путем его поворота против часовой стрелки и снимите его с машины (рис. 27)
3. Остатки кофе уберите пылесосом (рис. 28).
4. Влажной тряпкой очистите место расположения контейнера для зерен и высушите (рис. 29).
5. Установите контейнер в кофемолку. Контейнер установлен правильно, если стрелка ▲ выровнена с символом  и слышится щелчок (рис. 30).

8.3 Очистка жерновов

Когда выполняется очистка контейнера для зерен (A2), очистите место расположения контейнера и верхний жернов с помощью влажной тряпки. Обращайтесь в сервисный центр для снятия и замены жерновов.

Можно снять жернов, если кофемолка заблокирована посторонним предметом. Если это произошло, снимите контейнер для зерен и выполните следующее:

1. Закрепите фильтродержатель (C1) и выполните пустой помол для освобождения канала кофе.
2. Выключите прибор.
3. Поверните против часовой стрелки регулятор помола до упора в положение «REMOVE» (рис. 31).
4. Достаньте верхнюю часть жернова за специальную ручку (рис. 32).
5. Очистите жернов кисточкой (рис. 33) и пылесосом уберите кофейные остатки (рис. 28).

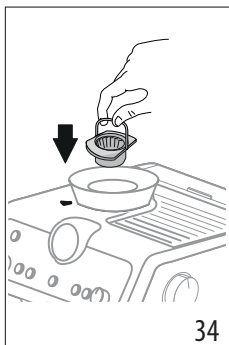
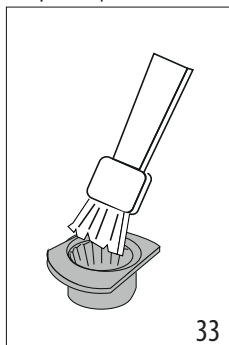

6. Установите жернов в свое гнездо (рис. 34).

7. Поверните регулятор и выберите желаемую степень помола (рис. 14).

Убедитесь, что жернов хорошо посажен, потянув его за ручку: он хорошо установлен, если не двигается.

8.4 Замена жерновов

Если количество молотого кофе снова уменьшается, обратитесь в сервисный центр для замены жерновов. Затем снова отрегулируйте кофемолку через меню настроек («7. Меню настроек») путем выбора первого диапазона дополнительной регулировки помола. Затем поверните рукоятку регулировки количества (B2) в положение MIN и отрегулируйте количество как при первом использовании (см. «Идеальное количество»).

8.5 Очистка Smart tamping station

1. Очистите зону крепления кисточкой (рис. 35).
2. Потяните рычаг (A20) до упора и кисточкой очистите придавливатель (рис. 36), затем отпустите рычаг.
3. С помощью ершика (C7) очистите желоб кофе (рис. 37).

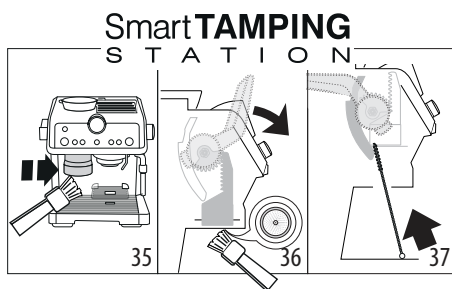

9. ЖЕСТКОСТЬ ВОДЫ

Индикатор  (B9) удаления накипи загорается через определенный период работы, продолжительность которого зависит от жесткости воды. Можно запрограммировать прибор на основании фактической жесткости воды в разных регионах. Таким образом увеличивается интервал проведения операции по удалению накипи.

1. Достаньте из упаковки индикаторную полоску из комплекта поставки TOTAL HARDNESS TEST (C4).
2. Полностью погрузите полоску в стакан воды на одну секунду.
3. Достаньте полоску из воды и отряхните ее. Настройте прибор, как указано в главе «7. Меню настроек».

Результат проверки жесткости воды	Кнопка	Степень
	× 2	1 мягкая вода

Результат проверки жесткости воды	Кнопка	Степень жесткости
		2 вода средней жесткости
		3 жесткая или очень жесткая вода

4. Настройте прибор, как указано в главе «7. Меню настроек».

10. КАК ПОЛЬЗОВАТЬСЯ SOFTBALLS

Softballs (C9) является инновационной системой, которая продлевает срок службы машины, не влияет на качество воды и обеспечивает подачу ароматного кофе с пышной пенкой. Для наибольшей эффективности оставьте Softballs в воде на всю ночь перед использованием.

1. Достаньте пакет Softballs из упаковки (рис. 38).

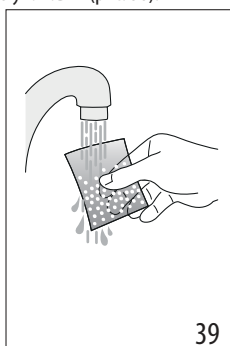
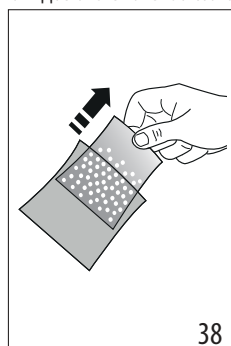

2. Ополосните проточной водой пакет Softballs (рис. 39).

3. Погрузите пакет в бак для воды (A14) (рис. 40).

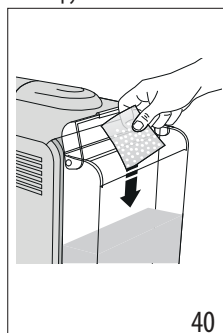

4. Заменяйте пакет Softballs каждые 3 месяца (рис. 41).

11. УДАЛЕНИЕ НАКИПИ

Внимание!

- Перед применением прочитайте инструкции и этикетку средства для удаления накипи (C5) на упаковке средства.
- Рекомендуется использовать только средство для удаления накипи компании De'Longhi. Использование неподходящих средств, а также нерегулярное удаление накипи могут вызвать неисправности, на которые не распространяется гарантия производителя.
- Средство для удаления накипи может повредить чувствительные поверхности. Если продукт случайно опрокинут, немедленно высушите.

Для удаления накипи

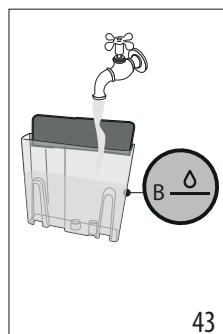
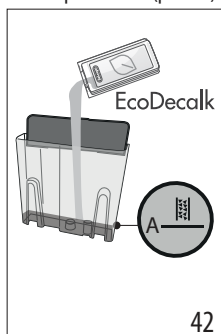

Средство для удаления накипи	Средство для удаления накипи De'Longhi
Емкость	Объем 2 литра
Время	~40 мин.

1. (СНИМИТЕ ФИЛЬТР СМЯГЧЕНИЯ ВОДЫ И SOFTBALLS, ЕСЛИ ИМЕЮТСЯ). Залейте в бак для воды (A14) средство для удаления накипи до уровня **A** (соответствует упаковке на 100 мл), указанного на внутренней стороне бачка (рис. 42).

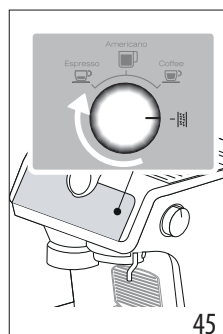
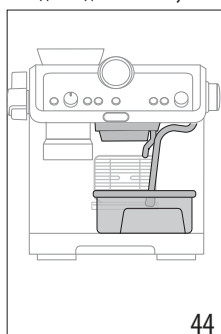

2. Долейте воду до уровня **B** (рис. 43). Установите бак для воды на машину.



3. Убедитесь, что фильтродержатель (С1) не закреплен, поместите емкость под узлы подачи кофе, горячей воды и под узел подачи пара (А6) (рис. 44).
4. Поверните рукоятку (В8) на  (рис. 45), индикатор ОК загорится оранжевым светом: начнет мигать световой индикатор .
5. Нажмите кнопку ОК: начнет мигать световой индикатор ОК.
6. Запускается программа удаления накипи, а жидкость для удаления накипи выходит из узлов подачи. Программа удаления накипи автоматически выполняет ряд ополаскиваний через заданные промежутки для удаления накипи изнутри кофемашины до полного опорожнения бачка для воды. Подача останавливается, а индикатор ОК становится белым. Необходимо выполнить цикл ополаскивания:
 7. Слейте емкость, использованную для сбора раствора для удаления накипи, и снова поместите ее под узлами подачи.
 8. Достаньте бачок для воды, слейте остатки раствора для удаления накипи, промойте его проточной водой и залейте свежую воду до отметки MAX (рис. 46). Установите бачок на место.
 9. Нажмите кнопку ОК, запускается ополаскивание.
 10. После завершения ополаскивания подача останавливается, а прибор готов к использованию.
 11. Слейте емкости сбора воды ополаскивания.
 12. Достаньте и слейте поддон для сбора капель, затем установите его на место.
 13. Достаньте бачок для воды и налейте свежую воду, затем поставьте его на место.
 Теперь прибор готов к применению.





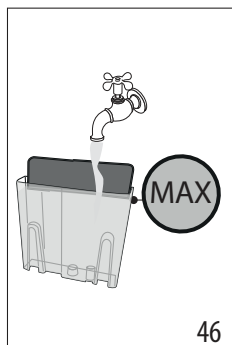







Примечание.

- Цикл удаления накипи можно запустить в любой момент (даже если соответствующий индикатор еще не горит).
- Если удаление накипи запущено по ошибке, удерживайте кнопку ОК в течение 10 секунд. Ополаскивание нельзя прервать.













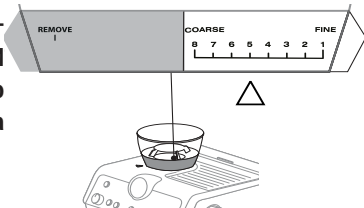
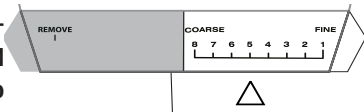

12. ЗНАЧЕНИЕ СВЕТОВЫХ ИНДИКАТОРОВ

ИНДИКАТОРЫ	ЗНАЧЕНИЕ ИНДИКАТОРОВ	СВЕТОВЫХ	ДЕЙСТВИЕ
Все индикаторы быстро мигают	Включение прибора		Самодиагностика
 горит ровно	Это первое включение кофемашины, поэтому необходимо наполнить контур воды.		Выполните действия, указанные в гл. "3. Первое включение прибора"
			→



ИНДИКАТОРЫ	ЗНАЧЕНИЕ ИНДИКАТОРОВ	СВЕТОВЫХ	ДЕЙСТВИЕ
 горит ровно (белый) <ul style="list-style-type: none"> Индикатор  : указывает выбранную температуру кофе Индикатор  : указывает, что машина готова к подаче горячей воды 	Машина готова к подаче		Подготовьте машину и выполните приготовление напитка
 горит ровно	Подключена функция энергосбережения.		Обратитесь к гл. “7. Меню настроек”, если хотите отключить функцию
 горит ровно	Контейнер для зерен (A2) пуст		Наполните контейнер для зерен
 мигает	Необходимо выполнить помол, но контейнер для зерен (A2) пуст		Наполните контейнер для зерен
 быстро мигает в регулярные промежутки	<p>Ручка (B2) повернута в положение максимальной регулировки</p> 		Если после помола кофе в фильтре недостаточно, выберите новый диапазон помола, как указано в главе “7. Меню настроек”.
 горит непрерывно	Недостаточно воды в бачке (A14) или бачок для воды плохо установлен		Наполните бачок или извлеките его и правильно установите.
 мигает	Необходимо выполнить приготовление напитка, но бачок для воды (A14) пуст		Заполните бачок для воды
	Слишком мелкий помол, кофе выходит медленно или не выходит вообще.		Снимите фильтродержатель (C1), повторите действия по приготовлению кофе с учетом инструкций из пар. «4.1 Этап 1 - Помол (grinding)» и «4.2 Этап 2 - Прессование (tamping)»
	Фильтр кофе (C2) или (C3) закупорен		Ополосните фильтры под проточной водой
	Бачок (A14) плохо установлен, а соответствующие клапаны не открыты		Слегка нажмите на бачок, чтобы открыть клапаны
	Наличие накипи в водяной системе		Выполните удаление накипи, как указано в гл. “11. Удаление накипи”
 горит ровно	Прибор готов к подаче пара		Прибор достиг температуры для подачи пара. Для начала подачи поверните рукоятку пара (A4)
 мигает	Прибор включен, подключена функция энергосбережения. Рукоятка пара (A4) находится в положении для подачи пара		Индикатор мигает, сообщая, что прибор готовится к подаче пара. Подача начнется, как только прибор нагреется до нужной температуры.
	Прибор готов к подаче пара		Если индикатор горит ровно, прибор нагрелся до температуры, необходимой для подачи пара
	Прибор подает пар		



ИНДИКАТОРЫ	ЗНАЧЕНИЕ ИНДИКАТОРОВ	СВЕТОВЫХ	ДЕЙСТВИЕ
 горит непрерывно	Контейнер для зерен не установлен		Правильно установите контейнер для зерен (A2) или убедитесь, что он правильно установлен. Контейнер установлен правильно, если стрелка ▲ выровнена с символом ☐ и слышен щелчок
 мигает	Неверная регулировка селектора степени помола, он находится за пределами максимальной возможной регулировки		<p>Приведите селектор в одно из положений помола (между 1 и 8), помните, что:</p> <ul style="list-style-type: none"> • следует регулировать помол, когда кофемолка находится в работе • следует регулировать на один уровень за раз и выполнить не менее 5 помолов между двумя регулировками
	<p>ЗА ПРЕДЕЛАМИ правильного диапазона</p> 		<p>Правильный диапазон</p> 
 горит ровно	Прибор требует прессование.		Только что был выполнен помол, и фильтродержатель закреплен на кофемолке.
	Фильтродержатель снят с кофемолки без предварительного прессования.		Снимите фильтродержатель и выполните прессование кофе, как представлено в пар. "Идеальное количество" "Если используется предварительно молотый кофе:"
	Фильтродержатель был снят до завершения помола, или прессование было выполнено слишком рано		Повторите помол
	Закупорен желоб кофе кофемолки		Выполните очистку, как указано в пар. "8.5 Очистка Smart tamping station". Если проблема не устранена, откройте дверцу для доступа к желобу и прочистите его ершиком
	Жернова заблокированы посторонним предметом		Удалите посторонний предмет и очистите жернова, как указано в пар. «8.3 Очистка жерновов».
 горит ровно (красный)	Необходимо выполнить удаление накипи		Выполните удаление накипи, как указано в гл. "11. Удаление накипи"
 мигает (красный) +  мигает (оранжевый)	Прибор выполняет удаление накипи		Завершите действие, как представлено в гл. "11. Удаление накипи"
			→

ИНДИКАТОРЫ	ЗНАЧЕНИЕ ИНДИКАТОРОВ	СВЕТОВЫХ	ДЕЙСТВИЕ
 мигает (красный) +  горит непрерывно (белый)	Необходимо ополаскивание	выполнить	
 мигает (красный) +  мигает (белый)	Прибор выполняет ополаскивание из цикла удаления накипи		
 горит ровно (оранжевый)	Необходимо выполнить очистку узла подачи кофе		См. пар. "8.1 Очистка узла подачи кофе"
 мигает (оранжевый)	Прибор выполняет очистку узла подачи кофе		
Все индикаторы мигают	Общее предупреждение		Обратитесь в сервисный центр

13. ЕСЛИ ИМЕЮТСЯ НЕПОЛАДКИ

ПРОБЛЕМА	ПРИЧИНА	УСТРАНЕНИЕ
Есть вода в поддоне для сбора капель (A10)	Это входит в нормальную работу внутренних контуров машины	Регулярно сливайте и очищайте поддон для сбора капель
Эспрессо не поступает	Нет воды в бачке (A14)	Заполните бачок
	Индикатор  (B6) горит, что означает, что контур кофе или контур пара пуст	Нажмите кнопку, соответствующую индикатору  , для заполнения контура
	Фильтр (C2) или (C3) закупорен	Ополосните фильтры под проточной водой
	Неправильно установлен бачок (A14), и клапаны на дне не открыты.	Слегка нажмите на бачок, чтобы открыть клапаны на дне.
	Наличие накипи в водяной системе	Выполните удаление накипи, как указано в гл. "11. Удаление накипи"
	Слишком мелкий помол	Снимите фильтродержатель (C1), повторите действия по приготовлению кофе с учетом инструкций из пар. "4.1 Этап 1 - Помол (grinding)" и "4.2 Этап 2 - Прессование (tamping)"
Держатель фильтра не закрепляется на приборе.	Молотый кофе не был придавлен, или его слишком много	Повторите помол с другими настройками. Уменьшите количество дозы. Убедитесь, что фильтр (C2) или (C3) (1 или 2 чашки) правильно подобран в зависимости от дозы для помола (кнопка 2x (B3) выбрана или нет)
		→

ПРОБЛЕМА	ПРИЧИНА	УСТРАНЕНИЕ
Кофе эспрессо выходит по краям фильтродержателя (C1) , а не из отверстий	Держатель фильтра плохо установлен	Правильно закрепите держатель фильтра и поверните его с усилием до упора
	Прокладка узла подачи кофе (A18) потеряла упругость или загрязнена	Замените прокладку узла подачи кофе в сервисном центре
	Фильтр (C2) или (C3) закупорен	Ополосните фильтры под проточной водой
Пенка кофе светлого цвета (кофе быстро выходит из носика).	Необходимо откорректировать настройки прибора	Снимите держатель, повторите действия по приготовлению кофе с учетом инструкций из пар. "4.1 Этап 1 - Помол (grinding)" и "4.2 Этап 2 - Прессование (tamping)"
Пенка кофе темного цвета (кофе медленно выходит из носика)	Необходимо откорректировать настройки прибора	Снимите фильтродержатель (C1), повторите действия по приготовлению кофе с учетом инструкций из пар. «4.1 Этап 1 - Помол (grinding)» и «4.2 Этап 2 - Прессование (tamping)»
После завершения удаления накипи прибор запрашивает еще одно ополаскивание.	Во время цикла ополаскивания бачок не был наполнен до отметки MAX	Повторите ополаскивание (см. гл. "11. Удаление накипи")
Прибор не выполняет помол кофе	Внутри кофемолки находится посторонний предмет	Выполните очистку жерновов, как указано в пар. «8.3 Очистка жерновов», убедитесь, что из контейнера для зерен удалены все зерна (A2) перед тем, как его достать. Перед установкой жернова на место тщательно уберите все остатки с места его расположения
	Контейнер для зерен (A2) в неправильном положении	Контейнер установлен правильно, если стрелка ▲ выровнена с символом ☐ и слышен щелчок
Если вы хотите поменять сорт кофе	Необходимо удалить все зерна, имеющиеся в машине	<ul style="list-style-type: none"> • Опорожните контейнер для зерен (A2) (с помощью пустых помолов или с помощью удаления оставшихся зерен). • Закрепите фильтродержатель (C1) и выполните помол вхолостую, чтобы освободить канал кофе. Закрепите держатель фильтра на выходе кофемолки (A19), выровняйте по надписи INSERT и поверните вправо держатель. Помол начинается, когда держатель достигает положения CLOSE, и прекращается автоматически. Повторите, пока фильтр не останется пустым • Поместите в контейнер (A2) новый сорт кофейных зерен • Если при помоле не достигается идеальное количество, выполните действия как при первом использовании
		➔

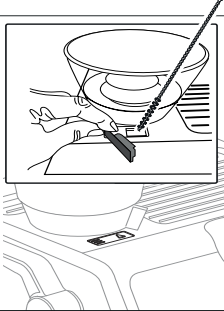
ПРОБЛЕМА	ПРИЧИНА	УСТРАНЕНИЕ
<p>После помола фильтр кофе (C2) или (C3) пуст</p> <p>После помола в фильтре слишком много кофейного порошка</p>	<p>Закупорен желоб кофе кофемолки</p>	<p>Выполните очистку, как указано в пар. «8.5 Очистка Smart tamping station». Если проблема не устранена, откройте дверцу (A21) для доступа к желобу и прочистите его ершиком</p> 
<p>После помола кофейный порошок в фильтре (C2) или (C3) не достигает идеального количества</p>	<p>Smart Tamping Station (выход кофемолки) нуждается в очистке</p> <p>Необходимо отрегулировать количество молотого кофе</p> <p>Со временем жернова изнашиваются</p>	<p>Выполните очистку, как указано в пар. «8.5 Очистка Smart tamping station», затем повторите помол</p> <p>Отрегулируйте количество при помощи специальной рукоятки (B2) согласно указаниям из пар. «Идеальное количество». Если рукоятка уже в положении макс, выполните действия, указанные в разделе «7. Меню настроек» - «Дополнительная регулировка помола»</p> <p>Выполните замену жерновов, как указано в пар. «8.4 Замена жерновов»</p>

Құрылғыны пайдаланбас бұрын әрқашан қауіпсіздік ережелерін оқып алыңыз.

1. СИПАТТАМАСЫ

1.1 Құрылғының сипаттамасы - А

- A1. Дән ыдысының қақпағы
- A2. Дән ыдысы
- A3. Кесе науасы
- A4. Бу тетігі
- A5. Ыстық су шүмегі
- A6. Бу түтігі
- A7. Эспрессоға арналған кесе торы
- A8. Шыныаяқтар мен кружкаларға арналған тор
- A9. Тамшы науасының торы
- A10. Тамшы науасы
- A11. Тамшы науасындағы су деңгейінің көрсеткіші
- A12. Су ыдысының қақпағы
- A13. Су ыдысын шығару тұтқасы
- A14. Су ыдысы
- A15. Су жұмсартқыш сүзгінің корпусы
- A16. Қуат сымын қосқыш ұяшығы
- A17. Негізгі қосқыш (ON/OFF)
- A18. Кофе шүмегі
- A19. Кофе тартқыштың шығысы (тығыздау станциясы)
- A20. Тығыздағыш тетігі
- A21. Кофе тартқыш құйғысының қақпағы

1.2 Басқару тақтасының сипаттамасы - В

- B1. ON/Standby түймесі
- B2. Тартылған кофе мөлшерін реттеу дөңгелегі
- B3. "2x" түймесі: 2 кофелік сүзгіні таңдау
- B4. Кофе температурасын реттеу түймесі
- B5. "OK" түймесі: сусынды құю/растау
- B6. Ыстық су түймесі
- B7. "Mu" түймесі: сусын мөлшерін реттеу
- B8. Функцияны таңдау дөңгелегі
 - Эспрессо
 - Американо
 - Кофе
 - Қақтан тазалау
- B9. "Қақ тазалау" шамы
- B10. "Бу дайын" шамы
- B11. "Дән ыдысы жоқ" шамы
- B12. "Қуат үнемдеу" шамы

- B13. "Тазалау" шамы ("8.1 Кофе шүмегінің тазалау" бөлімін қараңыз)
- B14. "Дән ыдысы бос" шамы
- B15. "Су жоқ" шамы
- B16. "Басу" шамы
- B17. Қысым манометрі

1.3 Қосалқы құралдардың сипаттамасы - С

- C1. Сүзгі ұстатқыш
- C2. 1 кесе сүзгісі
- C3. 2 кесе сүзгісі
- C4. "Жалпы қаттылықты тексеру" қағазы
- C5. Қақ тазартқыш
- C6. Алынбалы қуат сымы
- C7. Түтік щеткасы
- C8. Кофе шүмегінің тазалау керек-жарағы
- C9. Жұмсақ түйіршіктер
- C10. Сүт құтысы
- C11. Бу түтігін тазалау инесі

1.4 Өндіруші ұсынған тазалауға арналған қосымша қосалқы құралдар

Қосымша ақпарат алу үшін www.delonghi.com сайтына кіріңіз.

Тазалау таблеткасы

("8.1 Кофе шүмегінің тазалау" бөлімін қараңыз)



ØEcoMultiClean Тазалағыш

EAN коды: 8004399333307

2. ҚҰРЫЛҒЫНЫ ДАЙЫНДАУ

Барлық қосымша құралдарды жылы сумен және ыдыс жуғыш сұйықтықпен жуып, мына әрекеттерді орындаңыз:

1. Дән ыдысын (A2) кофе тартқышқа (1-сурет) салыңыз. ▲ көрсеткісі □ белгісіне тура келгенде және "сырт" еткен дыбыс естілгенде ыдыс орнына дұрыс түскені (2-сурет).
2. Тамшы науасын (A10) кесе торы (A8) және тамшы науасының торымен (A9) бірге орнына салыңыз (3-сурет);
3. Су ыдысын (A14) (4-сурет) шығарыңыз және таза сумен MAX деңгейінен (5-сурет) асырмай толтырыңыз.
4. Ыдысты құрылғыдағы орнына салыңыз.

Маңызды: Құрылғыны ыдысында су болмағанда немесе ыдыстың өзі болмағанда ешқашан пайдаланбаңыз.

Есіңізде болсын: Судың қаттылығын "7. Параметрлер мәзірі" бөліміндегі нұсқауларға жүгіне отырып, тез арада реттеңіз.

3. ҚҰРЫЛҒЫ ПАРАМЕТРЛЕРІН ОРНАТУ

1. Қуат сымның жалғағышын (С6) құрылғының артқы жағындағы ұяшыққа (А16) енгізіңіз (6-сурет), содан кейін розеткаға қосыңыз. Құрылғының артындағы негізгі қосқыштың (А17) басылғанына және I күйіне орнатылғанына көз жеткізіңіз (7-сурет);
 2. Ыстық су шүмегінің астына сыйымдылығы 100 мл бос ыдысты (кофе шүмегінің (А18) жанына) суретте көрсетілгендей қойыңыз (8-сурет).
 3.  индикатор шамының (9-сурет) жанындағы (В6) түймесін басыңыз: құю басталады да, автоматты түрде тоқтайды. Ыдысты босатыңыз.
- Кофе жасағышты пайдаланбас бұрын, құрылғының ішкі айналым жолдары шайылуы керек. Мына әрекетті орындаңыз:
4. Сүзгісі салынған сүзгі ұстатқышты (С1) құрылғыға бекітіңіз. Дұрыс бекіту үшін, сүзгі ұстатқыштың тұтқасын INSERT белгісіне (10-сурет) туралаңыз да, тұтқаны оңға қарай CLOSE белгісімен тураланғанша бұраңыз;
 5. Сүзгі ұстатқыштың және бу түтігінің (А6) астына ыдыс қойыңыз;
 6. ОК түймесін (В5) басыңыз: құю басталады (11-сурет);
 7. Қою аяқталған кезде, бу тетігін (А4) (12-сурет) бұрап, бу айналымын шаю үшін бірнеше секунд бу ытқытып шығарыңыз: ең жақсы нәтиже болуы үшін осы әрекетті 3 немесе 4 рет қайталаңыз. Бұл процедураның мақсаты – буды сусын дайындау мақсатында пайдалану алдында су айналымында қалған суды шығару.

Құрылғы пайдалануға дайын болады.

Есіңізде болсын: Құрылғы ұзақ уақыт бойы пайдаланылмаған кезде де ішкі жүйелерді шайған жөн.

Құрылғыны бірінші рет пайдаланған кезде, ол қанағаттанарлық нәтижені 4-5 кесе кофе жасағаннан кейін береді. Сүзгідегі ((С2) немесе (С3)) тартылған кофенің мөлшеріне ерекше назар аударыңыз ("4.1 1-қадам - ұнтақтау" бөліміндегі нұсқауларды көріңіз).

"Мінсіз мөлшер" бөлімінде сипатталғандай жалғастырыңыз.

4. КОФЕ ДАЙЫНДАУ

4.1 1-қадам - ұнтақтау

1. Дән ыдысына (А2) кофе дәндерін салыңыз (13-сурет). Дәндердің тек қазір қолданылатын мөлшерін ғана тартқан жөн, сонда кофе әрқашан жас болады.
2. Кофені тарту деңгейін таңдаңыз (14-сурет). Зауыттық параметр – 5 (орташа тарту). Егер ол тым майда немесе тым ірі болса, деңгейді жеке талғамға және қолданылудағы кофе түріне сай реттеңіз (реттеуді тек кофе тартқыш жұмыс істеп жатқан кезде ғана орындауға болады).

Есіңізде болсын: Көптеген кофелер үшін 3 және 6 аралығындағы тарту деңгейі ұсынылады. 1 немесе 2 тарту деңгейлері кофені тым ұсақ етеді, сондықтан оларды тек белгілі бір кофе түрлеріне (аз ғана қуырылған) ғана пайдаланған жөн

3. (С2) немесе (С3) тартылған кофе сүзгісіне сүзгі ұстағышқа (С1) (15-сурет) салыңыз; егер 2 кеселік сүзгі қолданылып жатса, 2х түймесін (В3) басыңыз: бұл сондай-ақ шүмектен ағатын эспрессо кофесінің мөлшерін екі еселендіреді.
4. Мөлшер деңгейін орнату үшін дөңгелекті (В2) ең аз күйден бастап жоғары қарай реттеңіз (16-сурет).

Қосымша нұсқауларды "Сүзгідегі тартылған кофе мөлшерін реттеу" бөлімінен қараңыз.

5. Сүзгі ұстатқышты кофе тартқыштың шығыс тесігіне (А19) бекітіп, оны "INSERT" жазуына туралаңыз да, оңға қарай бұраңыз. Кофені тарту сүзгі ұстатқыш CLOSE деңгейіне жеткен кезде басталып, автоматты түрде тоқтайды.

Сүзгідегі тартылған кофе мөлшерін реттеу



Кофені тартқан кезде, әртүрлі кофе сұрыптары әртүрлі нәтижені береді: сондықтан, мөлшерді бастапқыда реттегенде өте мұқият болуыңыз керек.

Бұл суретте қуыру түсіне байланысты мөлшерді реттеу әдісі көрсетілген: мұны жалпы нұсқау ретінде қабылдаған жөн, себебі іс жүзінде соңғы реттеу дәндердің құрамына байланысты әртүрлі болуы мүмкін.

1. Мөлшерді ең төменгі күйден бастап реттеңіз.
2. Белгілі бір дәндердің қуыру түсіне қарап, дұрыс деңгейді табу үшін дөңгелекті ақырын бұраңыз.

4.2 2-қадам - тығыздау

1. Кофе тарту қадамын орындай отырып, тығыздау тетігін (A20) толығымен төмен түсіріңіз (сүзгіні шүмек астындағы орнында қалдыра отырып) (17-сурет). Мінсіз нәтиже алу үшін осы қадамды екі рет қайталаңыз.
2. Сүзгі ұстағышты (18-сурет) шығару кезінде тығыздау тетігін толық төмен басып, одан кейін бастапқы күйіне қайтарыңыз.
3. Мөлшердің қажетті деңгейде екеніне көз жеткізе отырып ("Мінсіз мөлшер" бөлімін қараңыз), сүзгі ұстағышты (A18) (19-сурет) қайнатқыш шүмегіне бекітіңіз.

Есіңізде болсын: Басудан кейін сүзгінің жиектерінде қалған кофе ешбір жағдайда қайнату сапасына нұқсан келтірмейді, яғни, соңғы нәтижеге де әсер етпейді.

"Мінсіз мөлшер"

- Кофе сүзгілерінің ішіндегі анықтама белгісі мінсіз мөлшерді білдіреді.



Лазер белгісі

Бұдыр белгісі

- Лазер белгісі бар сүзгілер үшін: белгінің жоғарғы сызығы мінсіз мөлшерді білдіреді.
 - Бұдыр белгісі бар сүзгілер: бұдырлы сызық мінсіз мөлшерді білдіреді.
- Тығыздаудан соң, кофенің дұрыс деңгейде екеніне көз жеткізіңіз. Мінсіз мөлшерге қол жеткізу үшін деңгейді реттеу дөңгелегімен (B2) бірнеше рет реттеу қажет болуы мүмкін.
 - Егер кофе тіпті мінсіз дозада тым қою немесе тым ашық болып шықса, оны дәндерді майдалану немесе ірілеу етіп тарту арқылы реттеуге болады ("4.1 1-қадам - ұнтақтау" бөлімін қараңыз). Артып шығуды түзету үшін (кофе тым баяу шықса), ірілеу параметрді таңдаңыз. Кеміп шығуды түзету үшін (кофе тым тез шықса), майдалау параметрді таңдаңыз.
 - **Бариста кеңестері:** Сүзгі ұстағышын тетік (A20) әлі төменде тұрған кезде тығыздағыштан шығарыңыз, сонда кофе мөлшері мінсіз біркелкі болып шығады.
 - **Тартылған кофені пайдаланған кезде:**
 - тартылған кофені сүзгі ішіне қасықпен тығыздаңыз;
 - тетікті  күйіне бұраңыз;
 - сүзгі ұстағышты тартқыштың шүмегіне бекітіңіз;
 - тығыздау тетігін төменге түсіріңіз.

4.3 3-қадам - қайнату

1. Температураны таңдаңыз (20-сурет) ("Кофе дайындау температурасы" бөлімін қараңыз).
2. Қалаған сусынды таңдаңыз (21-сурет).
3. Қайнатуды бастау үшін ОК (B5) түймесін басыңыз (11-сурет) (демдеу және алдын ала демдеу). Кофе құйылуы автоматты түрде тоқтайды.

Кофе дайындау температурасы

Кофені ағызу барысында бүкіл дайындау процесінің тұрақтылығын қамтамасыз ету үшін судың температурасы бақыланады. Specialista Prestigio құрылғысында 3 демдеу

температурасы* бар, олар 92 және 96°C арасында реттеледі.

Температураның тиімді деңгейі дән сұрыбы мен қуырылу деңгейіне байланысты реттеледі: Робуста дәндері үшін төменірек, ал арабика дәндері үшін жоғарырақ температура қажет. Аз қуырылған және қатты қуырылған дәндер үшін де температура осылай реттеледі.

Температура деңгейі	Тиісті индикатор шамы	Қуыру түсі
Минимум		Қара
Орташа		Орташа-қара
Максимум		Ашық-Орташа

* Бұл – термоблоктағы судың температурасы. Сондықтан, мұны кеседегі сусынның немесе сүзгі ұстағыштың шүмектерінен шыққан кездегі сусынның температурасы деп ойламаңыз.

5. СҮТ СУСЫНДАРЫН ЖАСАУ

5.1 Сүтті көпіршіту

1. Құтыны (C10) қайнаған сүттің көлемі 2-3 есе ұлғаятынын есепке ала отырып жылытылатын/көпіршітетін сүт мөлшерімен толтырыңыз (22-сурет). Көпіршің тығыз және біркелкі болуы үшін сывырдың тоңазытқышта температурасында (шамамен 5°C) сақталған қаймағы алынбаған сүт қолданылуы керек.

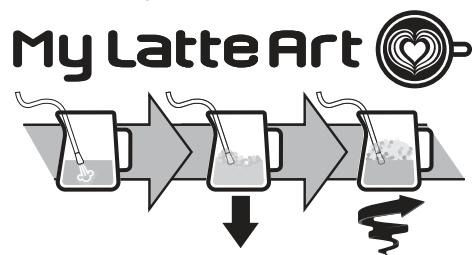

2. Сүтті көпіршіту үшін бу түтігінің (A6) саптамасын сұйықтықтың бетіне тигізіңіз: бұл ауаның сүтпен және бумен араласуына мүмкіндік береді.
3. Бу саптамасын тек сусынның бетіне тигізіңіз және тым көп ауа енгізбеңіз және қажетсіз үлкен көбіктерді шығармаңыз.
4. Саптама ұшын тек сүттің бетіне ғана батырыңыз, сонда сұйықтық ішінде иірілім пайда болады. Сүт қалаған температураға дейін қызған соң, буды өшіріңіз де, сүт құтысын құрылғыдан алмас бұрын ағудың толық тоқтағанын күтіңіз.

Бариста кеңестері:

- Жас сүтті пайдаланған өте жақсы болады. Әрқашан тоңазытқыштан жаңа ғана алынған жас сүтті пайдаланыңыз.
- Ең жақсы нәтижелер алу үшін сүт құтысы пайдаланылмаған кезде, оны тоңазытқышқа салып қойыңыз.
- Қаймағы алынбаған сүт жақсы нәтижелер береді. Көпіршіктің түрі мен текстурасы қолданылатын сүттің түрі мен көкөніс сусындарына байланысты болады.
- Сүтті көпірткен соң, құтыны жайлап айналдыра шайқау арқылы қажет емес көбіктерді жойыңыз.





Бу түтігін тазалау:

1. Қолданудан кейін су түтігін (23-сурет) әрқашан шүберекпен сүртіп, сүт қалдықтарын кетіріп отырыңыз. Тереңінен тазалау үшін ұсынылатын процедура – Eco MultiClean өнімін пайдалану: бұл өнім сүт ақуыздары мен майларын жою арқылы максималды тазалықпен қамтамасыз етеді және оны бүкіл құрылғыны тазалау үшін пайдалануға болады.
2. Бу түтігін тазалау үшін бірнеше секунд бу шығарыңыз (12-сурет).
3. Бу түтігі суығанша күтіңіз: уақыт өте келе бу түтігі тиімді жұмыс істеуі үшін 3 тесікті (24-сурет) арнайы тазалау құралымен (C11) кез келген кедергіден тазалаңыз.

6. КОФЕ СУСЫНДАРЫНЫҢ МӨЛШЕРІН

ТҮЙМЕСІМЕН (B7) РЕТТЕУ

1. Сүзгі ұстатқышты (C1) ((C2) немесе (C3) сүзгісі салынған және тартылған кофе салынған) бекіткен соң, құрылғыны

- жасағыңыз келген кофе сусынының 1 немесе 2 кесесін құюға дайындаңыз.
- Бағдарламаланатын сусынды таңдау үшін дөңгелекті (B8) бұраңыз.
 -  түймесін басыңыз:  түймесінің шамы жыпылықтайды.
 - Құюды бастау үшін ОК түймесін басыңыз. ОК және  түймелерінің шамдары жыпылықтайды.
 - Қажетті мөлшерге жеткен соң, ОК түймесін басыңыз. Егер сусында басқа ингредиент болса, құрылғы оны да құюды бастайды: қажетті мөлшер құйылған соң, ОК түймесін басыңыз.
 - Сақтау үшін  түймесін басыңыз. Осыдан кейін құрылғы қайта пайдалануға дайын болады және  шамы жанған күйде қалады.











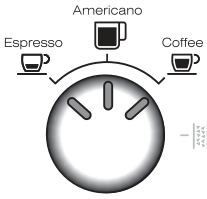

Егер жаңа параметрді сақтағыңыз келмесе, кез келген басқа түймені басыңыз.

Есіңізде болсын:

- Кофе сусындарын бағдарламалауға болады, бірақ бу және ыстық су құюды бағдарламалау мүмкін емес.
- Бағдарламалаудан соң тартылған кофе мөлшері емес, құйылатын сусынның мөлшері ғана өзгертіледі
- "2x" сусындарын бөлек бағдарламалауға болады.
- Әдепкі зауыттық параметрлерді қалпына келтіру үшін  түймесін шам сөнгенше басып тұрыңыз. Таңдалған сусын әдепкі мөлшерге қайта орнатылады.





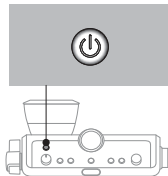

Кофе рецепті	Әдепкі мөлшер	Бағдарламаланатын мөлшер
 Espresso	35 мл	25-90 мл
 Espresso 2x	70 мл	50-180 мл
 Coffee	80 мл	50-120 мл
 Coffee 2x	160 мл	120-240 мл
 Americano	120 мл	• эспрессо: 25-60 мл • су: 25-120 мл
 Americano 2x	240 мл	• эспрессо: 50-120 мл • су: 50-240 мл

7. ПАРАМЕТРЛЕР МӘЗІРІ

1. Мәзірге кіріңіз:		
Бірге 5 секунд басып тұрыңыз	2x	
2. (B8) дөңгелегімен орнатылатын параметрлер		
		
Тиісті параметр	Келесіге бұраңыз	Параметрлер
Кофе тартуды қосымша реттеу	Espresso 	x2 ➔ 1-ауқым
		 ➔ 2-ауқым
Су қаттылығы	 Americano	x2 ➔ жұмсақ
		 ➔ орташа
		 ➔ қатты/өте қатты
Автоматты түрде өшіру	 Coffee	x2 ➔ 9 минут
		 ➔ 1.5 сағат
		 ➔ 3 сағат
3. Түймелермен орнатылатын параметрлер		
Қуат үнемдеу	 ➔ Белсенді	
	 ➔  Өшіру	
Әдепкі мәндер		Түймені кемінде 5 секунд басып тұрып  , шам тұрақты болып жанғанда жіберіңіз
➔		

4. Жаңа параметрлерді ON/Standby түймесін (B1) басу арқылы сақтаңыз



					
	×	×	✓	✓	×
	×	×	×	✓	✓









8. ҚҰРЫЛҒЫНЫ ТАЗАЛАУ

Маңызды!

- Кофе құрылғысын тазалау үшін еріткіштерді, қырғыш заттарды немесе спиртті пайдаланбаңыз.
- Қоқымдарды және кофе қалдықтарын кетіру үшін металдан жасалған заттарды пайдаланбаңыз, себебі олар құрылғының металл немесе пластмасса бөліктерін сырып тастауы мүмкін.
- Құрылғы бір аптадан астам уақыт бойы пайдаланылмайтын болса, кез келген сусынды дайындамас бұрын шаю циклін орындаған жөн болады.

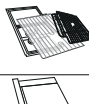

Қауіпті!

- Тазалау кезінде кофе жасағышты ешқашан суға батырмаңыз, себебі ол – электрлік құрылғы.
- Құрылғының сыртынан тазалау жұмыстарын бастамас бұрын, оны өшіріп, розеткадан суырып, суығанша күтіңіз.

					
	×	✓	✓	×	×
	✓	×	×	✓	✓
	×	×	×	✓	✓
	×	×	×	✓	✓
→					

8.1 Кофе шүмегіні тазалау

 шамы жанған кезде (қызғылт-сары) (B13), бұл кофе жолдарын тазалау қажет деген сөз. Ол үшін бөлек сатып алынуы тиіс, кофе жасағыш машиналарға арналған арнайы таблеткалар қажет. Қосымша ақпарат алу үшін www.Delonghi.com сайтына кіріңіз.

1. 1 кесе кофе сүзгісін (C2) сүзгі ұстатқышқа (C1) енгізіңіз (25-сурет).
2. Тазалау керек-жарағын сүзгіге (C8) (25-сурет) орналастырып, үй түймесін басыңыз.
3. Тазалау таблеткасын қосалқы құралға (26-сурет) салыңыз.
4. Сүзгі ұстағышты кофе шүмегіне (A18) бекітіңіз.
5. Ыдысты (A14) сумен толтырыңыз. Тамшы науасының (A10) бос екеніне көз жеткізіңіз.
6.  түймесін (B6)  (B13) шамы жанғанша басып тұрыңыз. Бірнеше минуттан соң, тазалау циклі автоматты түрде тоқтайды.
7. Сүзгі ұстағышты және тазалау қосалқы құралын шығарып алыңыз.
8. Сүзгі ұстағышты және сүзгіні ағын су астында жуыңыз.
9. Сүзгі ұстағышты орнына бекітіп,  түймесін басу арқылы шаю циклін орындаңыз: сүзгі ұстағыш астына бос ыдыс қойған жөн.
10. Тамшы науасын алып, босатыңыз.

Есіңізде болсын:

Осы тазалау циклін  түймесін бірнеше секунд басып тұру арқылы кез келген уақытта орындауға болады. Бас тарту үшін түймені кемінде 10 секунд басып тұрыңыз.

8.2 Дән ыдысының корпусын тазалау

1. Дән ыдысының (A2) бос екеніне көз жеткізіңіз. Күдіктенсеңіз, көз жеткізу үшін кофе тартқышқа аз ғана жұмыс істетіңіз.

- Ыдысты сағат тіліне қарсы бұрау арқылы босатып, құрылғыдан шығарып алыңыз (27-сурет).
- Кофе қалдықтарын шаңсорғышпен тазалаңыз (28-сурет).
- Дән ыдысының корпусын ылғал шүберекпен сүртіп, артынша құрғақ шүберекпен сүртіп кептіріңіз (29-сурет);
- Дән ыдысын кофе тартқыштағы орнына салыңыз. ▲ көрсеткісі □ таңбасына тураланғанда және "сырт" еткен дыбыс естілгенде, ыдыс орнына толық түскені (30-сурет).

8.3 Қашаутістерді тазалау

Дән ыдысын (A2) тазалап жатқан кезде, ыдыс корпусын және жоғарғы қашаутісті дымқыл шүберекпен тазалаңыз. Егер қашаутісті алып, ауыстыру қажет болса, қызмет орталығымен хабарласыңыз.

Егер кофе тартқыш бөгде зат кесірінен бітеліп қалса, қашаутісті шығарып алуға болады. Мұндай жағдай болса, дән ыдысын шығарып алып, мынаны орындаңыз:

- Сүзгі ұстағышты (C1) бекітіп, ішкі жолды босату үшін кофе тартқышты қысқа уақытқа іске қосыңыз.
- Құрылғыны өшіріңіз.
- Тартуды реттеу дөңгелегін сағат тіліне қарсы бағытта барған жеріне дейін, яғни, "REMOVE" күйіне дейін барғанша бұраңыз (31-сурет).
- Жоғарғы қашаутісті тұтқасынан ұстап, корпустан тартып шығарып алыңыз (32-сурет).
- Қашаутісті қылшақпен (33-сурет) тазалап, кофе қалдықтарын шаңсорғышпен алып тастаңыз (28-сурет).

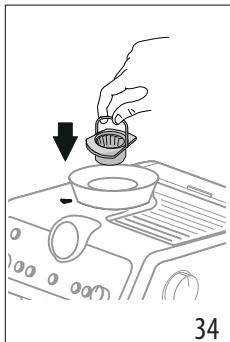
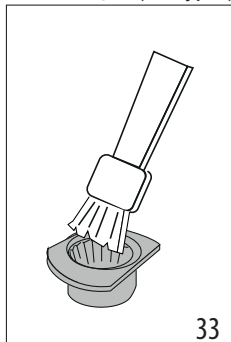

- Қашаутісті корпусқа салыңыз (34-сурет);
 - Реттеу дөңгелегін қалаған тарту деңгейін таңдау үшін бұраңыз (14-сурет);
- Тұтқаны тарту арқылы қашаутістің дұрыс орналастырылғанын тексеріңіз: ол орнына дұрыс түссе, қозғалмайды.

8.4 Қашаутістерді ауыстыру

Тартылған кофенің мөлшері күткендегіден аз болып шықса, қашаутістерді ауыстыру үшін қызмет көрсету орталығымен хабарласыңыз: жаңа қашаутістерді орнатқан соң, параметрлер мәзіріне ("7. Параметрлер мәзірі") кіру және "тартуды қосымша реттеу" параметрінің бірінші ауқымын таңдау арқылы кофе тартқышты реттеңіз. Одан кейін, тартылған кофе мөлшерін реттеу дөңгелегін (B2) MIN күйіне орнатып, бірінші рет қолданғанда салынуы тиіс мөлшерді салыңыз ("Мінсіз мөлшер" бөлімін қараңыз).

8.5 "Ақылды тығыздау станциясын"

тазалау

- Бекіту аймағын щеткамен тазалаңыз (35-сурет).
- Тетікті (A20) толығымен төменге басып, тығыздағышты щеткамен (36-сурет) тазалаңыз да, тетікті жіберіңіз.
- Кофе құйғысын (37-сурет) тазалау үшін түтік щеткамы (C7) пайдаланыңыз.

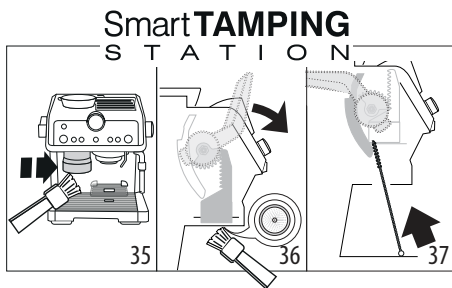

9. СУ ҚАТТЫЛЫҒЫ

Қақ тазалау шамы (B9) су қаттылығы параметріне байланысты алдын ала анықталған жұмыс кезеңінен кейін жанады. Бұл құрылғыны сіз тұратын жердегі нақты су қаттылығына сай бағдарламалауға да болады, сонда жиі қақ тазалау қажет болмайды.

- TOTAL HARDNESS TEST көрсеткіш қағазын (C4) орамынан шығарыңыз.

2. Қағазды стакандағы суға бір секундқа толығымен батырып алыңыз.
3. Қағазды судан шығарып, жайлап сілкіңіз. Құрылғыны "7. Параметрлер мәзірі" бөлімінде көрсетілгендей тиісінше орнатыңыз.

Су сынағының нәтижесі	Қаттылығы	Түйме	Деңгей
		x2	1 жұмсақ су
		≡ ⚙	2 орташа су
		○ OK	3 қатты немесе өте қатты су

4. Құрылғыны "7. Параметрлер мәзірі" бөлімінде көрсетілгендей тиісінше орнатыңыз.

10. ЖҰМСАҚ ТҮЙІРШІКТЕРДІ ПАЙДАЛАНУ ӘДІСІ

Жұмсақ түйіршіктер (C9) дегеніміз судың қасиеттерін өзгертпей, құрылғының жарамдылық мерзімін ұзартатын және кофені бірқалыпты қою және хош иісті ететін инновациялық жүйе. Өңдеудің тиімділігін жақсарту үшін жұмсақ түйіршіктерді қолданбас бұрын бір түнге суға салып қойыңыз.

1. Жұмсақ түйіршіктер қалташығын орамнан шығарыңыз (38-сурет).

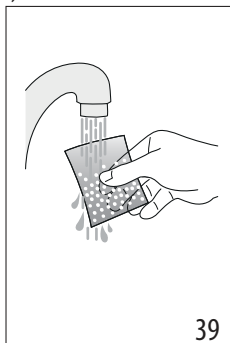
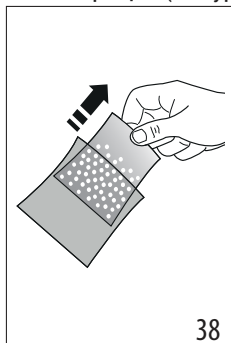

2. Жұмсақ түйіршіктер қалташығын ағын су (39-сурет) астында шайыңыз.
3. Қалташықты су ыдысына батырыңыз (A14) (40-сурет).

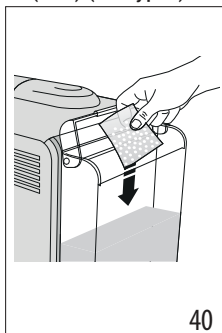

4. Жұмсақ түйіршіктер қалташығын 3 ай сайын ауыстырыңыз (41-сурет).

11. ҚАҚ ТАЗАЛАУ

Маңызды!

- Қақ тазалағышты (C5) қолданбас бұрын, нұсқауларды және қаптама жапсырмасындағы нұсқауларды оқып шығыңыз.
- Тек De'Longhi қақ тазалағышын пайдаланыңыз. Басқа қақ тазалағыш өнімдерді пайдалану және/немесе қақ тазалау процедурасын дұрыс орындамау өнім жасаушысының кепілдігінде қаралмаған ақаулықтарға себеп болуы мүмкін.
- Қақ тазалағыш нәзік беттерді зақымдауы мүмкін. Егер бұл өнім байқаусызда төгіліп кетсе, оны дереу құрғатыңыз.

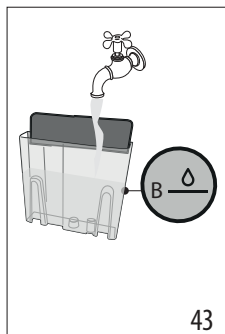
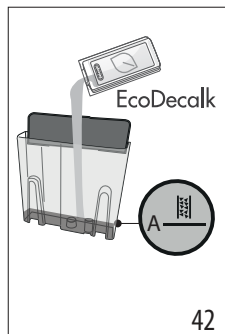

Қақ тазалау	
Қ а қ тазартқыш	De'Longhi қақ тазартқышы
Ыдыс	Сыйымдылығы – 2 литр
Уақыты	~40 мин

1. (ЕГЕР БОЛСА, СУ ЖҰМСАРТҚЫШТЫ ЖӘНЕ ЖҰМСАҚ ТҮЙІРШІКТЕРДІ ШЫҒАРЫП АЛЫҢЫЗ). Қақ тазалағышты су ыдысына (A14) ішіндегі бірінші деңгейге А дейін толтырып құйыңыз (бұл бір 100 мл қапшыққа тең) (42-сурет).

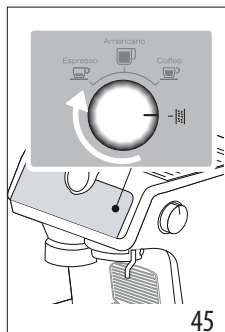
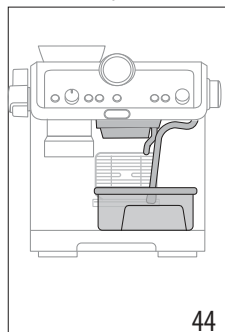

2. Суды $\frac{1}{2}$ В деңгейіне дейін құйыңыз (43-сурет). Сосын су ыдысын құрылғыға салыңыз.



3. Бұл кезде сүзгі ұстағышы (C1) бекітілмеген болуы керек. Кофе шүмегінің және ыстық су шүмегінің астына бос ыдыс қойып, бүтінгінің (A6) (44-сурет) астына да бөлек бір ыдыс қойыңыз.
4. Тетікті (B8)  күйіне (45-сурет) бұраңыз: ОК шамы қызғылт-сары түсте жанады:  шамы жыпылықтайды.
5. ОК түймесін басыңыз: ОК шамы жыпылықтайды.
6. Қақ тазалау бағдарламасы басталады және шүмектен қақ тазалағыш сұйық зат шығады. Қақ тазалау бағдарламасы құрылғының ішіндегі қақты тазалау үшін бірнеше шаю және кідіру әрекеттерін ыдыс босағанша орындайды.

Қақ тазалау тоқтап, ОК шамы енді ақ болып жанады. Бұл шаю циклі орындалуы қажет дегенді білдіреді:

7. Қақ тазалағыш ерітіндіні жинау үшін пайдаланылған ыдысты босатып, оларды шүмектер астына қайта қойыңыз.

8. Су ыдысын шығарып алып, қақ тазалағыш ерітіндінің кез келген қалдығынан босатыңыз да, ағын су астында шайып, MAX деңгейіне дейін таза сумен толтырыңыз (46-сурет). Су ыдысын корпусқа қайта салыңыз.

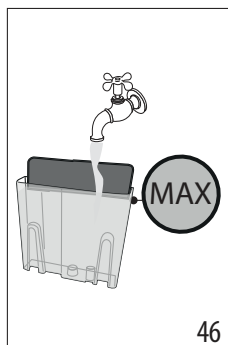





9. ОК түймесін басыңыз: шаю циклі басталады.
10. Шаю циклі аяқталған соң, су ағуы тоқтайды да, құрылғы пайдалануға дайын болады.
11. Шаятын суды жинау үшін қолданылатын ыдыстарды босатыңыз.
12. Тамшы науасын шығарып алып, босатыңыз да, құрылғыға қайта салыңыз.
13. Ыдысты шығарып, таза сумен толтырып, орнына қайта салыңыз.
- Осыдан кейін құрылғы пайдалануға дайын.



Есіңізде болсын:

- Қақ тазалау циклін кез келген уақытта бастауға болады (тиісті шам әлі жанбаса да).
- Қақ тазалау функциясы қателікпен іске қосылып кетсе, оны ОК түймесін 10 секунд басып тұру арқылы тоқтатуға болады; ал шаю циклін тоқтату мүмкін емес.

12. ИНДИКАТОР ШАМДАРЫНЫҢ ТҮСІНДІРМЕСІ

ШАМДАР	ШАМДАРДЫҢ ТҮСІНДІРМЕСІ	ЖҰМЫС ТҮРІ
Барлық шамдар аз ғана уақыт жыпылықтайды	Құрылғы іске қосылуда	Өзін-өзі тексеруде
 тұрақты жанады	Құрылғы бірінші рет іске қосылған және су айналу жолдары толтырылуы керек	Келесі бөлімде көрсетілген нұсқауларды орындаңыз: "3. Құрылғы параметрлерін орнату"
<p> тұрақты жанады (ақ)</p> <ul style="list-style-type: none"> •  шамы: таңдалған кофе температурасын көрсетеді •  шамы: құрылғының су құюға дайын екенін көрсетеді 	Құрылғы сұйықтықтарды құюға дайын	Құрылғы параметрлерін орнатып, сусын дайындауды бастаңыз
 тұрақты жанады	Қуат үнемдеу функциясы іске қосылған	Бұл функцияны ажырату туралы нұсқауларды "7. Параметрлер мәзірі" бөлімінен қараңыз
 тұрақты жанады	Дән ыдысы (A2) бос	Дән ыдысын толтырыңыз
 жыпылықтауда	Кофе тарту функциясы таңдалған, бірақ дән ыдысы (A2) бос	Дән ыдысын толтырыңыз
 тұрақты аралықтарда қысқа уақыт жыпылықтайды	<p>Дөңгелек (B2) MAX күйіне орнатылған</p> 	Сүзгідегі жаңа тартылған кофе жеткіліксіз болған кезде, "7. Параметрлер мәзірі" бөлімінде түсіндірілген жаңа кофе тарту ауқымын таңдаңыз.
 тұрақты жанады	Ыдыста жеткілікті бос орын жоқ (A14) немесе ыдыс орнына дұрыс салынбаған	Ыдысты сумен толтырыңыз немесе ыдысты алып, оны дұрыстап салыңыз
		→

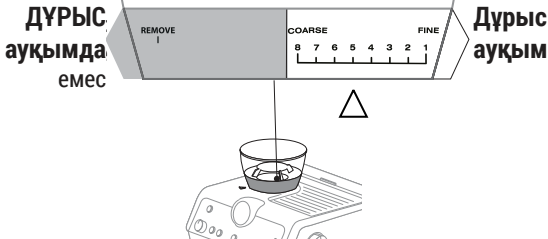
ШАМДАР	ШАМДАРДЫҢ ТҮСІНДІРМЕСІ	ЖҰМЫС ТҮРІ
 жыпылықтауда	Сусын дайындау әрекеті орындалуда, бірақ су ыдысы (A14) бос	Ыдысты сумен толтырыңыз
	Дәндер тым майда болып тартылғандықтан, кофе өте жай құйылуда немесе мүлдем құйылмауда	Сүзгі ұстағышты (C1) шығарып алып, кофе жасау қадамдарын қайталап орындаңыз, бірақ "4.1 1-қадам - ұнтақтау" және "4.2 2-қадам - тығыздау" бөлімдерінде көрсетілген нұсқауларды есепке алыңыз
	(C2) немесе (C3) кофе сүзгісі бітелген	Сүзгілерді ағын су астында шайыңыз
	Ыдыс (A14) орнына дұрыс салынбаған және тиісті клапандар ашылмаған	Клапандарды ашу үшін ыдысты үстінен жайлап басыңыз
	Су айналымында қақ қалыптасқан	"11. Қақ тазалау" бөлімде сипатталғандай етіп қақтан тазалаңыз
 тұрақты жанады	Құрылғы бу шығаруға дайын	Құрылғы бу шығаруға болатын ең қолайлы температураға жетті. Бу түтігінен бу шығару үшін бу дөңгелегін (A4) бұраңыз
 жыпылықтауда	Құрылғы іске қосулы және қуат үнемдеу функциясы жұмыс істеп тұр. Бу дөңгелегі (A4) бу шығару күйінде	Индикатор шамы құрылғының бу шығаруға дайындалып жатқанын көрсету үшін жыпылықтайды. Бу айналым жолы тиісті температураға жеткен кезде, құйылу басталады
	Құрылғы бу шығаруға дайын	Шам тұрақты жанған күйде қалған кезде, құрылғы тиісті температураға жеткені
	Құрылғы бу шығаруда	
 тұрақты жанады	Дән ыдысы орнына салынбаған	Дән ыдысын (A2) дұрыстап салыңыз немесе оның орнына дұрыс салынғанын тексеріңіз. Ыдыс ▲ көрсеткісі □ таңбасына тураланғанда және "сырт" еткен дыбыс шыққанда орнына дұрыс түскені
		→

ШАМДАР	ШАМДАРДЫҢ ТҮСІНДІРМЕСІ	ЖҰМЫС ТҮРІ
 жыпылықтауда	<p>Кофе тарту деңгейін реттеу таңдағышының параметрі дұрыс емес немесе ең жоғарғы рұқсат етілген деңгейден асып тұр</p> <p>ДҰРЫС ауқымда емес</p>  <p>Дұрыс ауқым</p>	<p>Таңдағышты қалыпты параметрлердің біріне қайтарыңыз (1 және 8 аралығында), бірақ мынаны ескеріңіз:</p> <ul style="list-style-type: none"> • Кофе тарту деңгейі кофе тартқыш жұмыс істеп тұрған кезде реттелуі тиіс • Тартқыш бір реттегенде тек бір деңгейге жылжытылуы тиіс және бір реттеуден келесі реттеуге дейін кемінде 5 рет пайдаланылуы керек
 тұрақты жанады	<p>Құрылғы кофеңі тығыздауды сұрайды</p> <p>Сүзгі ұстатқыш кофе тартқыштан кофеңі тығыздамай тұрып ажыратылған</p> <p>Сүзгі ұстағыш кофе тарту аяқталмай тұрып шығарылған немесе тығыздау қадамы тым тез орындалған</p> <p>Кофе тартқыштың құйғысы бітелген</p> <p>Қашауістерге бөгде заттар жабысқан</p>	<p>Кофе жаңа ғана тартылды және сүзгі ұстағыш кофе тартқышқа бекітілді</p> <p>Сүзгі ұстатқышты шешіп алып, кофеңі келесі бөлімде сипатталғандай етіп тығыздаңыз: "Мінсіз мөлшер" "Тартылған кофеңі пайдаланған кезде:"</p> <p>Кофе тарту қадамын қайталаңыз</p> <p>"8.5 "Ақылды тығыздау станциясын" тазалау" бөлімде сипатталғандай етіп тазалаңыз. Проблема қайталана берсе, құйғыға баратын ауыздың қақпағын ашып, түтік щеткамен бітелген жерді тазалаңыз</p> <p>Бөгде заттарды алып тастап, қашауістерді "8.3 Қашауістерді тазалау" бөлімінде түсіндірілгендей етіп тазалаңыз.</p>
→		

ШАМДАР	ШАМДАРДЫҢ ТҮСІНДІРМЕСІ	ЖҰМЫС ТҮРІ
 тұрақты жанады (қызыл)	Қақ тазалау қажет етіледі	Қақ тазалауды келесі бөлімде көрсетілгендей орындаңыз: "11. Қақ тазалау"
 жыпылықтайды (қызыл) +  жыпылықтайды (қызыл-сары)	Қақ тазалау орындалуда	Процедураны "11. Қақ тазалау" бөлімінде сипатталғандай етіп орындаңыз
 жыпылықтайды (қызыл) +  тұрақты жанады (ақ)	Шаю циклі орындалуы қажет	
 жыпылықтайды (қызыл) +  жыпылықтайды (ақ)	Қақ тазалау циклі аяқталған соң, шаю қадамы орындалады	
 тұрақты жанады (қызыл-сары)	Кофе шүмегін тазалау қажет	"8.1 Кофе шүмегін тазалау" бөлімін қараңыз
 жыпылықтауда (қызыл-сары)	Кофе шүмегін тазалау орындалуда	
Барлық индикатор шамдары жыпылықтайды	Жалпы ескерту	Тұтынушыларды қолдау қызметтерімен хабарласыңыз

13. АҚАУЛЫҚТАРДЫ ЖОЮ

ПРОБЛЕМА	СЕБЕБІ	ШЕШІМІ
Тамшы науасында (A10) су бар	Бұл су құрылғының ішкі айналым жолдарынан шығады және бұл олардың жұмысынан кейін болатын қалыпты нәрсе	Тамшы науасын тұрақты түрде босатыңыз және тазалаңыз
→		

ПРОБЛЕМА	СЕБЕБІ	ШЕШІМІ
Құрылғы эспрессо кофесін жасай алмауда	Ыдыста су жоқ (А14)	Су ыдысын толтырыңыз
	☞ (В6) шамы кофе немесе бу айналымы бос екенін көрсету үшін жанады	Жүйені толтыру үшін ☞ шамына тиесілі түймені басыңыз
	(С2) немесе (С3) кофе сүзгісі бітелген	Сүзгілерді ағын су астында шайыңыз
	Ыдыс (А14) орнына дұрыс салынбаған және оның түбіндегі клапандар ашық емес	Түбіндегі клапандарды ашу үшін ыдысты үстінен жайлап басыңыз
	Су айналымында қақ қалыптасқан	"11. Қақ тазалау" бөлімде сипатталғандай етіп қақтан тазалаңыз
	Кофе тым майда етіліп тартылған	Сүзгі ұстағышты (С1) шығарып алып, кофе жасау қадамдарын қайталап орындаңыз, бірақ "4.1 1-қадам - ұнтақтау" және "4.2 2-қадам - тығыздау" бөлімдерінде көрсетілген нұсқауларды есепке алыңыз
Сүзгі ұстағыш құрылғыға бекітілмеуде	Тартылған кофе тығыздалмаған немесе кофе мөлшері тым көп	Кофе тарту қадамдарын әртүрлі параметрлермен қайталап көріңіз. Доза мөлшерін азайту: (С2) немесе (С3) сүзгісі (1 немесе 2 кесе) мен кофе тарту мөлшері бір-біріне сәйкес екенін (2x түймесі (В3) таңдалған немесе таңдалмағанын) тексеріңіз
Эспрессо кофесі тесіктерден емес, сүзгі ұстағыштың (С1) жиектерінен тамшылайды	Сүзгі ұстағышы дұрыс бекітілмеген	Сүзгі ұстатқышты дұрыс бекітіңіз және жеткен жеріне дейін мықтап бұраңыз
	Кофе шүмегінің (А18) аралық тығыздағышының иілгіштігі нашарлаған немесе ол кірлеген	Кофе шүмегінің аралық тығыздағышын қызмет орталығына ауыстыртыңыз
	(С2) немесе (С3) кофе сүзгісі бітелген	Сүзгілерді ағын су астында шайыңыз
→		

ПРОБЛЕМА	СЕБЕБІ	ШЕШІМІ
Эспрессо кілегейі тым ақ (шүмектен тым тез ағады)	Құрылғы параметрлері қайта орнатылуы керек	Сүзгі ұстағышты шығарып алып, кофе жасау қадамдарын қайталап орындаңыз, бірақ "4.1 1-қадам - ұнтақтау" және "4.2 2-қадам - тығыздау" бөлімдерінде көрсетілген нұсқауларды есепке алыңыз
Эспрессо кілегейі тым қара (шүмектен тым баяу ағады)	Құрылғы параметрлері қайта орнатылуы керек	Сүзгі ұстағышты (C1) шығарып алып, кофе жасау қадамдарын қайталап орындаңыз, бірақ "4.1 1-қадам - ұнтақтау" және "4.2 2-қадам - тығыздау" бөлімдерінде көрсетілген нұсқауларды есепке алыңыз
Қақ тазалау циклі аяқталған соң, құрылғы шаю циклін орындауды сұрайды	Шаю циклі барысында су ыдысы MAX деңгейіне дейін толтырылмаған	Шаю циклін қайталаңыз ("11. Қақ тазалау" бөлімін қараңыз)
Құрылғы кофені тартпайды	Кофе тартқышта бөгде зат бар	Қашаутістерді "8.3 Қашаутістерді тазалау" бөлімінде түсіндірілгендей тазалап, дән ыдысын (A2) оны шығарып алмас бұрын оның ішіндегі дәндердің барлығын алып тастаңыз. Қашаутісті орнына салмас бұрын, барлық қалдықтарды корпустан шаңсорғышпен алып тастаңыз
	Дән ыдысы (A2) орнына дұрыс салынбаған	▲ көрсеткісі  таңбасына тураланғанда және "сырт" еткен дыбыс естілгенде, ыдыс орнына толық түскені
→		

ПРОБЛЕМА	СЕБЕБИ	ШЕШІМІ
Басқа кофе түріне ауыстыру	Қазір құрылғы ішінде тұрған кофе алынып тасталуы керек	<ul style="list-style-type: none"> • Дәндер ыдысын (A2) босатыңыз (кофе тартқышын дән салмай жұмыс істету немесе ішінде қалған дәндерді шаңсорғышпен тазалау арқылы) • Ішкі жолды тазалау үшін сүзгі ұстағышты (C1) орнына бекітіп, кофе тартқышты дәндер салынбаған күйінде шамалы жұмыс істетіңіз: енді сүзгі ұстағышты кофе тартқыштың шүмегіне (A19) INSERT белгісіне туралай отырып бекітіңіз де, оны оңға қарай бұраңыз. Кофені тарту сүзгі ұстатқыш CLOSE деңгейіне жеткен кезде басталып, автоматты түрде тоқтайды. Осы әрекетті сүзгі босағанша қайталаңыз • Ыдысты (A2) жаңа кофе дәндері сұрыбымен толтырыңыз • Егер тартылған кофе мөлшері күткен мінсіз мөлшер болмай шықса, құрылғы параметрлерін құрылғыны алғашқы пайдалануға дайындаған кездегідей реттеңіз
		→

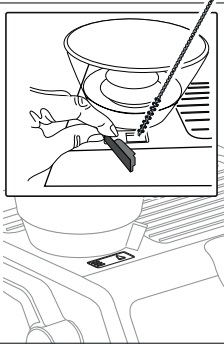
ПРОБЛЕМА	СЕБЕБИ	ШЕШІМІ
<p>Кофені тартқан соң, (C2) немесе (C3) кофе сүзгісі босайды</p> <p>Кофені тартқан соң, сүзгіде тым көп кофе қалады</p>	<p>Кофе тартқыштың құйғысы бітелген</p>	<p>"8.5 "Ақылды тығыздау станциясын" тазалау" бөлімде сипатталғандай етіп тазалаңыз. Проблема қайталана берсе, құйғыға баратын ауыздың қақпағын (A21) ашып, түтік щеткамен бітелген жерді тазалаңыз</p> 
<p>Кофені тартқан соң, (C2) немесе (C3) сүзгісінің ішіндегі кофе мөлшері "мінсіз мөлшерге" жетпейді</p>	<p>"Ақылды тығыздау станциясы" тазалануы керек</p> <p>Тартылған кофе мөлшері реттелуі қажет</p> <p>Уақыт өте келе қашаутістер тозады</p>	<p>"8.5 "Ақылды тығыздау станциясын" тазалау" бөлімінде түсіндірілгендей тазалап, тарту қадамын қайталаңыз</p> <p>Кофе мөлшерін дөңгелекпен (B2) реттеп, ""Мінсіз мөлшер"" бөліміндегі нұсқауларды орындаңыз. Егер дөңгелек макс. күйінде бұған дейін тұрған болса, онда "7. Параметрлер мәзірі" - "Кофе тартуды қосымша реттеу" бөлімінде түсіндірілген әрекетті орындаңыз</p> <p>Қашаутістерді "8.4 Қашаутістерді ауыстыру" бөлімінде көрсетілгендей ауыстырыңыз.</p>

A készülék használata előtt mindig el kell olvasni a biztonságos használatra vonatkozó figyelmeztetéseket tartalmazó füzetet.

1. LEÍRÁS

1.1 A készülék leírása - A

- A1. Szemes kávé tartó fedele
- A2. Szemes kávé tartó
- A3. Csészetartó
- A4. Gőz szabályozógomb
- A5. Forró víz adagoló
- A6. Gőz adagoló cső
- A7. Csészetartó rács espresso kávéhoz
- A8. Csészetartó rács pohárhoz vagy mug csészéhez
- A9. Csepptálca rács
- A10. Csepptálca
- A11. A csepptálcában lévő víz szintjét mutató piros úszó
- A12. Víztartály fedél
- A13. Víztartály kiemelő fogantyú
- A14. Víztartály
- A15. Vízlágyító szűrő helye
- A16. Tápkábel csatlakozó helye
- A17. Főkapcsoló (ON/OFF)
- A18. Kávé adagoló
- A19. Kávédaráló kimenet (Tamping station)
- A20. Kávétömörítő kar
- A21. Fedél a kávédaráló csúszdájához

1.2 Kezelőfelület leírása - B

- B1. ON/Standby gomb
- B2. Őrölt kávé mennyiségét szabályozó gomb
- B3. „X2” gomb: a 2 kávé szűrő használatához
- B4. „Kávé hőmérséklete” gomb
- B5. „OK” gomb: az ital adagolásához/jóváhagyáshoz
- B6. „Forró víz adagoló” gomb
- B7. „My” gomb: az italok hosszúságának egyéni ízlés szerinti beállítása
- B8. Funkcióválasztó gomb
 - Espresso
 - Americano
 - Kávé
 - Vízköoldás
- B9. „Vízköoldás” jelzőfény
- B10. „Gőz készen van” jelzőfény
- B11. „Nincs szemes kávé tartó” jelzőfény
- B12. „Energiatakarékosság” jelzőfény
- B13. „Tisztítás” jelzőfény (lásd „8.1 A kávéadagoló tisztítása”)
- B14. „Szemes kávé tartó üres” jelzőfény
- B15. „Nincs víz” jelzőfény
- B16. „Tömörítés” jelzőfény
- B17. Manométer

1.3 A tartozékok leírása - C

- C1. Szűrőtartó egység
- C2. 1 csésze szűrő
- C3. 2 csésze szűrő
- C4. Vízkeménység mérő csík "Total Hardness Test"
- C5. Vízköoldószer
- C6. Eltávolítható tápkábel
- C7. Tisztító kefe
- C8. Kávéadagoló tisztító tartozék
- C9. Softballs
- C10. Tejes kancsó
- C11. Tisztító tű a gőzfúvókához

1.4 A szállítás a tisztító tartozékokat nem tartalmazza, de a gyártó által ajánlottak

További információért látogasson el a Delonghi.com weboldalra.



Tisztító tabletták

(Lásd „8.1 A kávéadagoló tisztítása”)

 **Tisztítószer**
EAN: 800439933307

2. A KÉSZÜLÉK ELŐKÉSZÍTÉSE

Langyos vízzel és konyhai mosogatószerrel mossa el az összes tartozékot, majd az alábbiak szerint járjon el:

1. Tegye a szemes kávé tartót (A2) a kávédarálóba (1. ábr.). A tartály megfelelően van behelyezve, ha a ▲ nyíl a  szimbólumhoz igazodik, és „kattanást” hall (2. ábr.).
2. Helyezze be a csepptalcát (A10) és a csészetartó rácsot (A8), valamint a csepptálca rácsot (A9) (3. ábr.);
3. Vegye ki a víz tartályt (A14) (4. ábr.) és töltsze fel friss, tiszta vízzel, ügyeljen arra, hogy a víz ne lépje túl a MAX jelzést (5. ábr.).
4. Majd helyezze be a tartályt.

Figyelem: *Soha ne indítsa be a készüléket, ha a tartályban nincs víz vagy a tartály nincs a helyén.*

Megjegyzés: *Tanácsos minél előbb beállítani a víz keménységét a „7. Beállítások menü” című fejezetben leírtak szerint.*

3. A KÉSZÜLÉK ELSŐ BEINDÍTÁSA

1. Illesse a tápkábel csatlakozóját (C6) a készülék hátulján kialakított helyre (A16) (6. ábr.); majd illesse a villásdugót a csatlakozó aljzatba. Győződjön meg arról, hogy a készülék hátulján lévő főkapcsoló (A17) I állásban van lenyomva (7. ábr.);
2. Helyezzen a forró víz adagoló alá (a kávéadagolóval egyvonalban (A18)) egy legalább 100 ml úrtartalmú edényt (8. ábr.);
3. Nyomja meg a gombot (B6) a jelzőfényrel egy magasságban  (9. ábr.): kezdetét veszi az adagolás és automatikusan félbeszakad. Ürítse ki a tartót.

A gép használata előtt át kell öblíteni a gép belső hidr. köreit. Az alábbiak szerint járjon el:

4. Akassza a szűrőtartó egységet (C1) a gépre: a helyes akasztáshoz állítsa egy vonalba a szűrőtartó egység karját az „INSERT” szimbólummal (10. ábr.) és forgassa a nyelet jobbra, amíg egy vonalba nem kerül el a „CLOSE” pozícióval;
5. Helyezzen egy edényt a szűrőtartó egység és a gőz adagoló cső alá (A6);
6. Nyomja meg az OK gombot (B5) (11. ábr.): az adagolás megindul;
7. Az adagolás végén forgassa el a gőz szabályozógombot (A4) (12. ábr.) és engedjen ki gőzt pár másodpercig a gőz kör tisztítása érdekében: a gőz megfelelő kiengedéséhez javasoljuk, hogy ismétlje meg ezt a műveletet 3 vagy 4 alkalommal. Ez lehetővé teszi a víz eltávolítását a csőből, mielőtt kiengedné a gőzt.

A készülék készen áll a használatra.

Megjegyzés: A belső körök öblítését a készülék hosszabb leállása után is ajánlott elvégezni.

Első használatkor 4-5 kávét kell lefőzni, mielőtt a készülék kielégítő eredményt produkálna: különösen figyeljen a szűrőbe tett őrölt kávé adagra ((C2) vagy (C3)) (lásd a „4.1 1. szakasz - őrlés (grinding)” bekezdésben foglalt utasításokat).

A „A„tökéletes adag”” fejezetben leírtak szerint járjon el.

4. KÁVÉKÉSZÍTÉS

4.1 1. szakasz - őrlés (grinding)

1. Öntse a kávészemeket a tartóba (A2) (13. ábra). Javasoljuk, hogy mindig csak az elkészítéshez szükséges kávészem-mennyiséget öntse be: így mindig friss kávét használj;
2. Válassza ki az őrlés finomságát (14. ábr.). A gyári beállítás az 5 (közepes finomságú őrlés). Ha az eredmény nem kielégítő, állítsa be a szintet az egyéni ízlésnek és a kávé típusának megfelelően (a beállítást a kávédaráló működése közben kell elvégezni).

Megjegyzés: A legtöbb kávé esetében a 3 és 6 közötti őrlés finomság javasolt. Az 1 vagy 2 beállítással darált kávé eredménye nagyon finom őrlemény, csak különleges kávékhoz javasolt (kevésbé pörkölt).

3. Helyezze be az egyik kávészűrőt (C2) vagy (C3) a szűrőtartóba (C1) (15. ábr.). Ha a 2 csészéhez való szűrőt használja, nyomja meg az X2 gombot (B3): ezzel a választással megkettőzi az adagolt espresso mennyiségét is.
4. Forgassa el a mennyiség beállító gombot (B2) a minimum helyzetről indulva (16. ábr.).

További információért lásd a „Szabályozza a szűrőben lévő őrölt kávé mennyiségét” bekezdést.

5. Akassza a szűrőtartót a kávédaráló kimenetére (A19), az INSERT felirattal egyvonalban: ezután forgassa jobbra az

egységet. Az őrlés akkor veszi kezdetét, amikor a kar eléri a CLOSE pozíciót és automatikusan félbeszakad.

Szabályozza a szűrőben lévő őrölt kávé mennyiségét



Minden kávészem fajta más-más eredményt ad az őrlés során, ezért különös gonddal kell eljárni az adag első beállításakor.

Ez a magyarázat utasításokat ad arra vonatkozóan, hogy hogyan állítsa be az adagot a pörkölés színe alapján: ezt kiindulási pontként kell kezelni, amely változhat a kávészemek összetétele alapján.

1. A minimum pozíciótól kell beállítani az adagot.
2. A kávé pörkölési színének alapján forgassa lassan a gombot.

4.2 2. szakasz - Tömörítés (tamping)

1. Az őrlés után engedje le a tömörítő kart (A20) a végállásig (ne vegye ki a szűrőtartót) (17. ábr.). A tökéletes eredményért ismétlje meg 2-szer.
2. Tartsa lent a kart végállásban a szűrőtartó eltávolítása során (18. ábr.). Ezután helyezze vissza a kart az eredeti helyzetébe.
3. Miután ellenőrizte, hogy a kávé adag megfelelő (lásd „A „tökéletes adag””, csatlakoztassa a szűrőtartót a kávéadagolóra (A18) (19. ábr.).

Megjegyzés: Ha a tömörítés után a szűrő peremén marad némi kávé, az egyáltalán nem befolyásolja az adagolás minőségét, illetve a végeredményt.

A „tökéletes adag”

- A kávészűrők egy belső jellel rendelkeznek a tökéletes adag jelöléséhez.



- Lézer jelöléssel rendelkező szűrők: a tökéletes adag jelölés felső vonalának felel meg;
- Domború jelöléssel rendelkező szűrők: a tökéletes adag a jelölés kidomborodó vonalának felel meg;

- Győződjön meg arról, hogy a kávé a tömörítés után egy szintben van. Lehetséges, hogy többször kell beállítani a gombot (B2), mielőtt eléri a tökéletes adagot.
- Ha a kávé túl- vagy alul kivont, és az adag a tökéletes adagon belül van, állítsa finomabbra vagy durvábbra az őrlés mértékét (lásd „4.1 1. szakasz - Őrlés (grinding)”). Ha a kávé túlzottan kivont (az adagolás túl lassú), az őrlésnek durvábbnak kell lennie. Ha a kávé kevésbé kivont (az adagolás túl gyors), az őrlésnek finomabbnak kell lennie.
- **A barista javaslata:** Akkor húzza ki a szűrőtartót, amikor a tömörítő kar (A20) le van engedve, hogy a kávé adagja tökéletes legyen.
- **Ha előre őrlött kávékat használ:**
 - öntse az előre őrlött kávé a szűrőbe;
 - forgassa a kapcsológombot  állásba;
 - akassza a szűrőtartót a kávédaráló kimenetére;
 - engedje le a tömörítő kart.













4.3 3. szakasz - Adagolás (brewing)

1. Válassza ki a hőmérsékletet (20. ábr.) (lásd „A kávékészítéshez szükséges hőmérséklet”).
2. Válassza ki a kívánt italt (21. ábr.).
3. Nyomja meg az OK gombot (B5) az adagolás megkezdéséhez (11. ábra) (előinfúzió és infúzió). A kávé adagolása automatikusan leáll.

A kávékészítéshez szükséges hőmérséklet

A víz hőmérséklete a kávékészítés teljes folyamata során ellenőrzött, így garantált a stabilitása a kivonás során. A Specialista Prestigio 3 kávéfőzési hőmérséklet* kínál, melyek egy 92 °C és 96 °C közötti tartománynak felelnek meg.

A kávézsemek fajtájától és pörkölésétől függően különböző hőmérséklet javasolt: a Robusta kávézsemekhez alacsony hőmérséklet, míg az Arabica kávézsemekhez magas hőmérséklet szükséges. Ugyanez érvényes a sötét pörkölésű vagy kevésbé pörkölt kávézsemekre.

Hőmérséklet szintje	Vonatkozó jelzőfény	Pörkölés szintje
MIN	   	Sötét
MED	   	Közepes-sötét
MAX	   	Világos - sötét

- * Ez a hőmérséklet a thermoblock rendszerben lévő vízre vonatkozik. Ezért eltér a csészében lévő ital hőmérsékletétől vagy a szűrőtartó adagolóján keresztül kifolyó ital hőmérsékletétől.

5. TEJ ALAPÚ ITALOK KÉSZÍTÉSE

5.1 A tej habosítása

1. Öntsön a kancsóba (C10) annyi tejet, amennyit melegíteni/habosítani kíván, de vegye figyelembe, hogy a tej térfogata 2 vagy 3-szorosára fog növekedni (22. ábr.). Sűrűbb és homogénebb tejhab készítéséhez tanácsos zsíros, hűtőszekrény-hőmérsékletű tehéntejet (kb. 5 °C) használni.

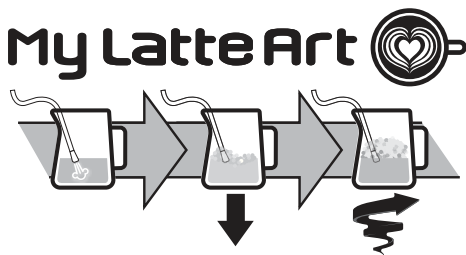

2. A tej habosításához helyezze a gőz adagoló csövet (A6) a tej felületére: ennek során a levegő összekeveredik a tejjel és a gőzzel.
3. Tartsa a gőzfúvókát a felületen, ügyelve arra, hogy ne fogjon egyszerre túl sok levegőt, amely túl nagy buborékokat képez.
4. Merítse a gőz adagolót a tej felszíné alá: ezzel örvényt hoz létre. A kívánt hőmérséklet elérése után zárja el a gőz szabályozó gombot és várja meg, amíg a gőz adagolás teljesen leáll, mielőtt kivenné a tejkancsót.

A barista javaslata:

- **A friss tej a legjobb.** Mindig friss, hűtőszekrény-hőmérsékletű tejet használjon.
- Jobb eredményért tanácsos a tejeskancsót mindig a hűtőszekrénybe tenni.
- A zsíros tej kiváló eredményeket biztosít. Az eredmény és a hab textúrája a felhasznált tehéntejtől vagy növényi italoktól függően változik.
- Miután felhabosította a tejet, a kancsót körkörös mozgassa finoman a buborékok eltávolításához.

A gőz adagoló tisztítása:

1. Minden használat után ruhával távolítsa el a tejmaradványokat a gőz adagolóból (23. ábr.). Az alapos tisztításhoz tanácsos az Eco MultiClean-t használni: a tejfehérjék és tejszírok eltávolításával biztosítja a higiéniát, és az egész gép tisztítására használható.
2. Engedjen pár másodpercig gőzt az adagoló megfelelő tisztításához (12. ábr.).







3. Várja meg, amíg az adagoló lehűl: ahhoz, hogy fenntartsa az adagoló hatékonyságát az idők során, használja a tisztító tüt (C11), hogy a 3 lyuk szabad maradjon (24. ábr.).

6. EGYÉNI ÍZLÉS SZERINT ÁLLÍTSA BE A KÁVÉ ALAPÚ ITALOK HOSSZÚSÁGÁT A (my) (B7) GOMBBAL







- Készítse elő a gépet 1 vagy 2 csésze kávé alapú ital készítésére, akassza be a szűrőtartót (C1) a szűrővel (C2) vagy (C3) és darált kávé.
- Forgassa el a gombot (B8) a programozandó ital kiválasztásához.
- Nyomja meg a (my) gombot: a (my) gombnak megfelelő jelzőfény villog.
- Az adagolás megkezdéséhez nyomja meg az OK gombot. Az OK és a gomboknak megfelelő fények (my) villognak.
- Miután elérte a kívánt mennyiséget, nyomja meg az OK gombot. Ha az ital más összetevő adagolását is igényli, akkor megkezdődik annak adagolása: ha elérte a kívánt mennyiséget, nyomja meg az OK gombot.
- Nyomja meg a (my) gombot a mentéshez. A készülék készen áll az új használatra, és a jelzőfény (my) folyamatosan világít. Ha nem akarja menteni a programozást, nyomjon meg egy bármely más gombot.

Megjegyzés:

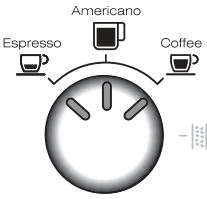
- A kávé alapú italokat lehet programozni, de a gőz és a forró víz adagolást nem.
- A programozás módosítja az italok mennyiségét, de az örlött kávéét nem.
- Az „X2” italokat külön-külön is be lehet programozni.
- A gyári beállításaihoz való visszatéréshez tartsa lenyomva a (my) gombot a kikapcsolásig. A kiválasztott ital visszaáll a gyári beállított mennyiségre.

Kávé recept	Gyári mennyiség	Programozható mennyiség
 Espresso	35 ml	25-től 90 ml-ig
 Espresso X2	70 ml	50-től 180 ml-ig
 Coffee	80 ml	50-től 120 ml-ig
 Coffee X2	160 ml	120-től 240 ml-ig
 Americano	120 ml	<ul style="list-style-type: none"> espresso: 25-től 60 ml-ig víz: 25-től 120 ml-ig
 Americano X2	240 ml	<ul style="list-style-type: none"> espresso: 50-től 120 ml-ig víz: 50-től 240 ml-ig

7. BEÁLLÍTÁSOK MENÜ

1. Lépjen a menübe:		
Tartsa nyomva egyidejűleg 5 másodpercig	x2	(my)
2. Beállítások a kapcsológomb általi kiválasztással (B8)		
		
Megfelelő beállítás	Forgassa a	Beállítások
A kávéadagoló extra beállítása	 Espresso	x2 → Range 1
		☰ → Range 2
Vízke ménység	 Americano	x2 → lágy
		☰ → közepes
		(OK) → kemény/nagyon kemény
Automata kikapcsolás	 Coffee	x2 → 9 perc
		☰ → 1,5 óra
		(OK) → 3 óra
3. Beállítások gomb általi kiválasztással:		
Energiatakarékosság	 → Bekapcsolt	
	 → Kikapcsolt	
Gyári értékek		Legalább 5 másodpercig tartsa lenyomva a (my) gombot, amíg a jelzőfény folyamatosan világít
4. Az ON/Standby (B1) megnyomásával mentse el az új beállításokat		
→		

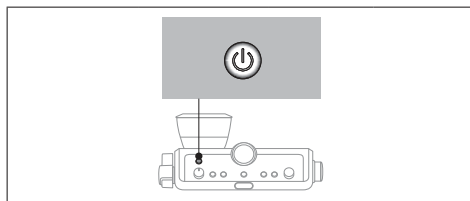

8. A KÉSZÜLÉK TISZTÍTÁSA

Figyelem!

- A készülék tisztításához ne használjon oldószereket, súrolószereket vagy alkoholt.
- A kávézacc vagy egyéb lerakódások eltávolításakor nem szabad fémtárgyakat használni, mert ezek megkarcolhatják a gép fém- vagy műanyag felületeit.
- Egy hétnél hosszabb állás esetén javasoljuk, hogy az újbóli használat előtt öblítse ki a gépet.

Veszély!

- Tisztítás során soha ne merítse a készüléket vízbe: az egy elektromos berendezés.
- A készülék külső tisztításának megkezdése előtt kapcsolja ki a gépet, húzza ki a hálózati csatlakozót, és hagyja a készüléket kihűlni.

	✗	✓	✓	✗	✗
	✓	✗	✗	✓	✓
	✗	✗	✗	✓	✓
	✗	✗	✗	✓	✓
	✗	✗	✓	✓	✗
	✗	✗	✗	✓	✓

8.1 A kávéadagoló tisztítása

Amikor a jelzőlámpa kigyullad (narancssárga) (B13), meg kell tisztítani a kávé kört. A tisztítási ciklus elvégzéséhez vásárol-

jon a kávéfőzőkhöz való tisztító tablettákat. További információért látogasson el a www.Delonghi.com oldalra.

1. Helyezze az 1 csésze szűrőt (C2) a szűrőtartóba (C1) (25. ábr.).
2. Helyezze a tisztító tartozékot (C8) a szűrőbe (25. ábr.) és nyomja le teljesen.
3. Tegye a tisztító tablettát a tartozékra (26. ábr.).
4. Csatlakoztassa a szűrőtartót a kávéadagolóra (A18).
5. Töltse fel a víztartályt (A14). Ellenőrizze, hogy a csepptálca (A10) üres-e.
6. Tartsa lenyomva a (B6) gombot, amíg fel nem gyullad a jelzőfény (B13). Néhány perc múlva a tisztítás automatikusan leáll.
7. Távolítsa el a szűrőtartót és a tisztító tartozékot.
8. Mossa el a szűrőtartót és a szűrőt folyó víz alatt.
9. Helyezze vissza a szűrőtartót, és folytassa az öblítéssel a gomb megnyomásával: ajánlott egy edényt a szűrőtartó alá tenni.
10. Vegye ki és irtse ki a csepptálcát.

Megjegyzés:

Ez a tisztítási ciklus bármikor elindítható a gomb néhány másodperces lenyomásával. A művelet megszakításához nyomja a gombot 10 másodpercig.

8.2 Tisztítsa meg a szemes kávé tartó házát

1. Ellenőrizze, hogy a szemes kávé tartó (A2) üres-e. Ha szükséges, végezzen néhány üres örlést annak kiürítéséhez.
2. Az óramutató járásával ellentétes irányba forgatva oldja ki a tartályt, és vegye ki a gépből (27. ábr.).
3. A kávé maradványokat szívja fel (28. ábr.).
4. Tisztítsa meg a szemes kávé tartó házát nedves ruhával és szárítsa meg (29. ábr.);
5. Helyezze vissza a tartót a kávédarálóba. A tartály megfelelően van behelyezve, ha a nyíl a szimbólumhoz igazodik, és „kattanást” hall (30. ábr.).

8.3 A daralók tisztítása

A szemes kávé tartó (A2) tisztításakor nedves ruhával tisztítsa meg a tartályfészket és a felső daralót. A daralók eltávolításához és cseréjéhez forduljon szervizközponthoz.

A daraló eltávolítható, ha a kávédaralót idegen test blokkolja. Ha ez megtörténik, vegye ki a szemes kávé tartót és az alábbiak szerint járjon el:

1. Helyezze vissza a szűrőtartó egységet (C1) és örljön egyet „üresen” a kávécsatorna felszabadításához.
2. Kapcsolja ki a készüléket.
3. Forgassa az örlés szabályozóját az óramutató járásával ellentétes irányba ütközésig, „REMOVE” pozícióba (31. ábr.).
4. Az erre a célra szolgáló fogantyúval húzza ki a daraló felső részét (32. ábr.).

5. Tisztítsa meg a darálót egy ecsettel (33. ábr.) és szívja el a kávémaradványokat egy porszívóval (28. ábr.).

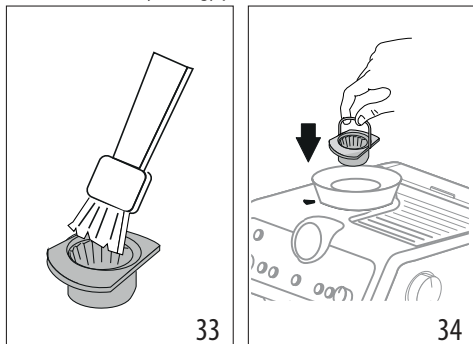

6. Helyezze a darálót a helyére (34 ábr.);
7. Forgassa el a szabályozót, a kívánt őrlési fok kiválasztásával (14 ábr.);

Ellenőrizze, hogy a daráló megfelelően van-e behelyezve, a fogantyúnál fogva húzza: a daráló megfelelően van behelyezve, ha nem mozog.

8.4 Daralók cseréje

Ha az őrölt kávé mennyisége tovább csökken, lépjen kapcsolatba a szervizközponttal a daralók cseréjéhez: majd állítsa be újra a darálót a beállítások menübe („7. Beállítások menü”) lépve és az extra őrlésbeállítás első tartományának kiválasztásával. Ezután fordítsa a mennyiség beállító gombot (B2) MIN állásba, és állítsa be az adagot az első használathoz hasonlóan (lásd „A,,tökéletes adag”).

8.5 A „Smart tamping station” tisztítása

1. Tisztítsa meg az akasztási területet egy ecsettel (35 ábr.).
2. Húzza meg a kart (A20) a végállásig és tisztítsa meg egy ecsettel a tömörítőt (36. ábr.): majd engedje vissza a kart.
3. Egy kefével (C7) tisztítsa meg a kávé csúszdát (37 ábr.).

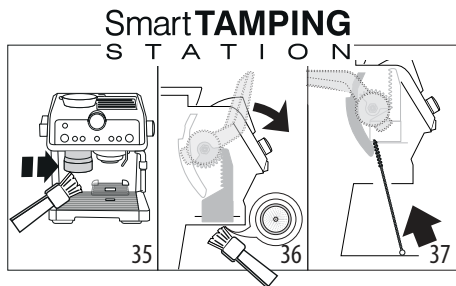

hatja a terület vízvezeték hálózatát jellemző valós vízkeménységre, így a készülék ritkábban végez vízköoldást.

1. Vegye ki a csomagolásból a készletben lévő vízkeménység mérő csíkot "TOTAL HARDNESS TEST" (C4).
2. Körülbelül egy másodpercre merítse a csíkot egy pohár vízbe.
3. Vegye ki a csíkot a vízből és enyhén rázza meg. A,,7. Beállítások menü” fejezet szerint állítsa be a készüléket.

A vízkeménységi eredménye	teszt	Gomb	Szint
	×2		1 lágy víz
	≡ [®]		2 közepes víz
	OK		3 kemény vagy nagyon kemény víz

4. A,,7. Beállítások menü” fejezet szerint állítsa be a készüléket.

10. A SOFTBALLS HASZNÁLATA

A Softballs (C9) egy innovatív rendszer, amely meghosszabbítja a gép élettartamát anélkül, hogy megváltoztatná a víz minőségét, és így krémes és aromás kávét biztosít. Hatékonyságuk optimalizálása érdekében hagyja a Softballs-okat egész éjjel vízben ázni, mielőtt felhasználná őket.

1. Vegye ki a Softballs csomagot a csomagolásból (38. ábr.).

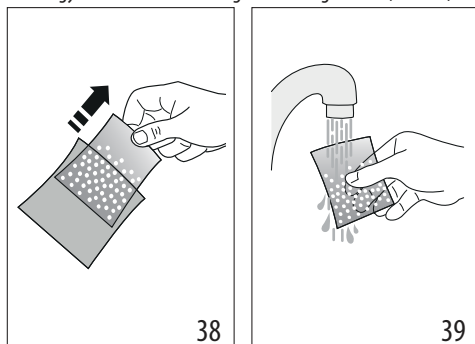

2. Öblítse le folyó víz alatt a Softballs csomagot (39. ábr.).
3. Merítse a csomagot a víztartályba (A14) (40. ábr.).

9. VÍZKEMÉNYSÉG

A (B9) vízköoldás jelzőfény egy, a víz keménységétől függő, előre beállított időtartam után felgyullad. A készüléket beállít-

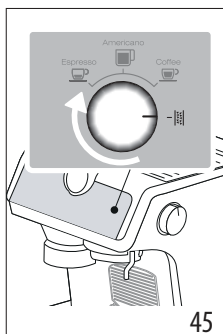
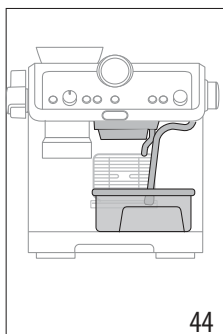
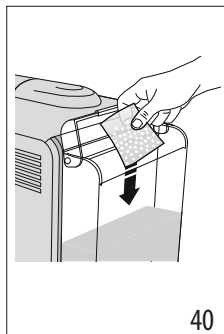

4. 3 havonta cserélje ki a Softballs csomagot (41. ábr.).

11. VÍZKŐOLDÁS

Figyelem!

- Használat előtt olvassa el a vízkőoldószert csomagolásán található utasításokat és a címkét (C5).
- Kizárólag De'Longhi vízkőoldó használatát javasoljuk. Nem megfelelő vízkőoldó használata, valamint a nem szabályszerűen végzett vízkőoldás olyan károkat okozhat, melyek javítása nem tartozik a gyártó által vállalt garancia körébe.
- A vízkőoldó károsíthatja a kényes felületeket. Ha a termék véletlenül kiömlik, azonnal itassa fel.

A vízkőoldás elvégzéséhez	
Vízkőoldószert	De'Longhi vízkőoldószert
Edény	Kapacitás 2 liter
Idő	~40 perc

1. (HA VAN, VEGYE KI A VÍZLÁGYÍTÓ SZŰRŐT ÉS A SOFTBALLS-T). Öntsön a víztartályba (A14) vízkőoldót a tartály belső oldalára vésett A szintig (ez egy 100 ml-es csomagolásnak felel meg) (42. ábr.).

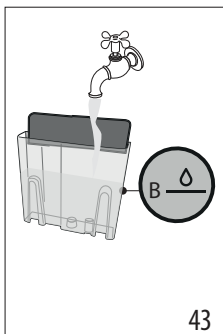
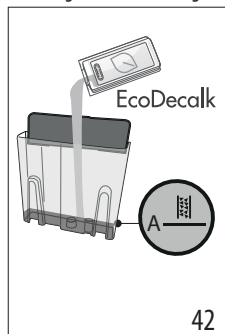

2. Adjon hozzá vizet a B szint eléréséig (43. ábr.). Tegye vissza a víztartályt a gépbe.

3. Győződjön meg arról, hogy a szűrőtartó (C1) nincs beakasztva és helyezzen egy edényt a kávé és a forró víz adagoló, valamint a gőz adagoló (A6) alá (44. ábr.).

4. Forgassa a kapcsológombot (B8) a állásba (45. ábra): az OK jelzőfény narancssárgán világít; a jelzőfény villog.

5. Nyomja meg az OK gombot: a OK jelzőfény villog.

6. A vízkőoldó program elindul, és a vízkőoldó folyadék az adagolón keresztül távozik. A vízkőoldó program során a készülék meghatározott időközönként számos átmosást végez, amellyel eltávolítja a kávéfőző készülékben képződött vízkövet és teljesen kiüríti a tartályt.

Az adagolás megszakad és az OK jelzőfény fehérre vált. El kell végezni az öblítési ciklust:

7. Üritse ki a vízkőoldó folyadék összegyűjtéséhez használt edényt és tegye az adagoló alá.

8. Vegye ki a víztartályt, öntse ki belőle a vízkőoldó folyadék esetleges maradványait, öblítse ki folyó vízzel és töltsze fel friss vízzel a MAX szint jelzésig (46. ábr.). Tegye vissza a tartályt a helyére.

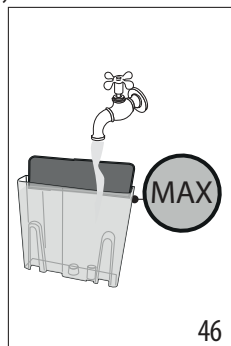

9. Nyomja meg az OK gombot: az öblítés elindul.
10. Az öblítés végén az adagolás megszakad és a készülék készen áll a használatra.
11. Üritse ki az öblítővíz összegyűjtésére használt edényeket.
12. Emelje ki és ürítse ki a csepptálcát, majd tegye vissza.
13. Emelje ki és töltsze fel a tartályt friss vízzel, majd tegye vissza.











Ekkor a készülék készen áll a használatra.





Megjegyzés:









- A vízköoldó ciklust bármely pillanatban el lehet indítani (akkor is, ha a vonatkozó jelzőfény még nem ég).

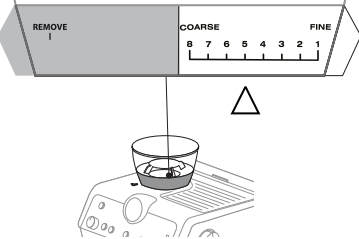

- Ha a vízköoldást tévedésből indította el, nyomja meg az OK gombot 10 másodpercig; az öblítést nem lehet félbeszakítani.

12. A JELZŐFÉNYEK JELENTÉSE



JELZŐFÉNYEK	A JELZŐFÉNYEK JELENTÉSE	MŰVELET
Az összes jelzőfény röviden villog	A készülék bekapcsolása	Önellenzés
 folyamatosan égő	Ez a gép első beindítása és a hidr. kört fel kell tölteni vízzel	Az alábbi fejezetben leírtak szerint járjon el. "3. A készülék első beindítása"
 folyamatosan világít (fehér) <ul style="list-style-type: none"> •  jelzőfény: a kiválasztott kávé hőmérsékletét jelzi •  jelzőfény: jelzi, hogy a gép készen áll a forró víz adagolására 	A készülék készen áll az adagolásra	Készítse elő a gépet és folytassa az ital elkészítésével
 folyamatosan égő	Az energiatakarékoság funkció aktív	Lásd a "7. Beállítások menü" fejelet. a funkció kikapcsolásához
 folyamatosan égő	A szemes kávé tartó (A2) üres	Töltse meg a szemes kávé tartót
 villogó	Kávét kíván darálni, de a szemes kávé tartó (A2) üres	Töltse meg a szemes kávé tartót
 rövid ideig, szabályos időközökkel villog	A kapcsológombot (B2) a maximális beállítás állásába forgatták 	Ha a kávédarálás után a szűrőben lévő kávé nem elegendő, válasszon egy új őrlési tartományt a "7. Beállítások menü" fejezetben leírtak szerint.
 folyamatosan ég	A tartályban lévő víz (A14) mennyisége nem elegendő vagy a víztartály nem megfelelően van betéve	Töltse fel a tartályt vagy vegye ki vagy a víztartályt nem jól van betéve
		→

JELZŐFÉNYEK	A JELZŐFÉNYEK JELENTÉSE	MŰVELET
 villogó	Italt kíván készíteni, de a víztartály (A14) üres	Töltse meg a víztartályt
	A kávé túl finomra őrölte, így a kávé csak nagyon lassan vagy egyáltalán nem folyik le	Vegye ki a szűrőtartó egységet (C1), ismétlje meg a kávéfőző műveleteket a „4.1 1. szakasz - Őrlés (grinding)” és „4.2 2. szakasz - Tömörítés (tamping)” bekezdések figyelembevételével
	A (C2) vagy (C3) kávé szűrő eltömődött	Öblítse le a szűrőket folyó vízzel
	A tartály (A14) rosszul van behelyezve és a vonatkozó szelepek nincsenek nyitva	Finoman nyomja meg a tartályt úgy, hogy a szelepek kinyíljanak
	Vízkezelő van a hidr. rendszerben	Végezze el a vízköoldást a „11. Vízköoldás” fejezetben leírtak szerint.
 folyamatosan égő	A készülék készen áll a gőz adagolására	A készülék elérte a gőz adagolásához szükséges hőmérsékletet. Az adagolás megkezdéséhez forgassa el a gőz szabályozógombot (A4)
 villogó	A készülék be van kapcsolva és az energiatakarékosság funkció aktív: a gőz szabályozógomb (A4) gőz adagoló pozícióban áll	A villogó jelzőfényt azt jelzi, hogy a készülék készül a gőz adagolására: az adagolás azonnal megkezdődik, amint a készülék eléri a hőmérsékletet
	A készülék készen áll a gőz adagolására	A készülék hőmérséklete akkor megfelelő a gőz készítéséhez, ha a jelzőfényt folyamatosan kezd el égni
	A készülék gőzt enged ki	
 folyamatosan égő	A szemes kávé tartó nincs behelyezve	Helyezze be megfelelően a szemes kávé tartót (A2) vagy ellenőrizze, hogy megfelelően van-e behelyezve. A tartály megfelelően van behelyezve, ha a ▲ nyíl a ☞ szimbólumhoz igazodik, és „kattanást” hall
→		

JELZŐFÉNYEK	A JELZŐFÉNYEK JELENTÉSE	MŰVELET
 villogó	<p>Az őrlési fokot kiválasztó kapcsoló beállítása nem megfelelő vagy a lehető legnagyobb beállítási fokon túlhaladt</p>	<p>Állítsa a választókapcsolót az egyik őrlési pozícióba (1 és 8 között), figyelvén arra, hogy:</p> <ul style="list-style-type: none"> Az őrlést akkor kell beállítani, amikor a kávédaráló működésben van Egyszerre egy szintet állítson és legalább 5 darálást végezzen, mielőtt másik állásba forgatja
	<p>TARTOMÁNYON kívül helyes</p>  <p>Tartomány helyes</p>	
 folyamatosan ég	<p>A készülék tömörítést igényel</p>	<p>A gép éppen most végzett darálást és a szűrőtartót a kávédarálóra akasztották</p>
	<p>A szűrőtartót leakasztották a kávédarálóról, de nem tömörítettek</p>	<p>Akassa le a szűrőtartót és tömörítse a kávé a bekezdésben leírtak szerint. "A „tökéletes adag”" "Ha előre őrölt kávé használ.""</p>
	<p>A szűrőtartót lecsavarták anélkül, hogy befejezték volna a darálást vagy túl gyorsan végeztek el a tömörítést</p>	<p>Ismételje meg az őrlést</p>
	<p>A kávédaráló kávé csúszdája el van tömödve</p>	<p>Végezze el a tisztítást a "8.5 A „Smart tamping station” tisztítása" bekezdésben leírtak szerint. Ha a probléma továbbra is fennáll, nyissa ki a csúszda fedelét és a tisztító kefével szabadítsa fel a csúszdát</p>
	<p>A darálók idegen test miatt leálltak</p>	<p>Távolítsa el az idegen testet és tisztítsa meg a darálókat a „8.3 A darálók tisztítása" bekezdésben leírtak szerint.</p>
 folyamatosan világít (piros)	<p>El kell végezni a vízköoldást</p>	<p>Végezze el a vízköoldást az alábbi bekezdés szerint. "11. Vízköoldás"</p>
 villog (piros) +  villog (narancssárga)	<p>A készülék vízköoldást végez</p>	<p>A műveletet a "11. Vízköoldás" fejezetben leírtak szerint végezze.</p>
 villog (piros) +  folyamatosan égő (fehér)	<p>Öblítést kell végezni</p>	
 villog (piros) +  villog (fehér)	<p>A készülék a vízköoldó ciklus öblítési szakaszát végzi</p>	
→		

JELZŐFÉNYEK	A JELZŐFÉNYEK JELENTÉSE	MŰVELET
 folyamatosan égő (narancssárga)	Meg kell tisztítani a kávéadagolót	Lásd a "8.1 A kávéadagoló tisztítása" bekezdést.
 villogó (narancssárga)	A készülék a kávéadagoló tisztítását végzi	
Az összes jelzőfény villog	Általános riasztás	Forduljon egy márkaszervizhez

13. HA VALAMI NEM MŰKÖDIK

PROBLÉMA	OK	MEGOLDÁS
Víz van a csepptálcában (A10)	Ez a gép belső köreinek normál működési jelensége	Rendszeresen ürítse ki és tisztítsa meg a csepptálcát
Nem jön ki több presszókávé	Nincs víz a tartályban (A14)	Töltse fel a tartályt
	A  (B6) jelzőfény világít jelezvén, hogy a kávékör vagy a gőz kör üres	Nyomja meg a  jelzőfényhez tartozó gombot a hidr. kör feltöltése érdekében
	A (C2) vagy (C3) szűrő eltömődött	Öblítse le a szűrőket folyó vízzel
	A tartály (A14) rosszul van behelyezve és az alján található szelepek nincsenek nyitva	Finoman nyomja meg a tartályt úgy, hogy az alján lévő szelepek kinyíljanak
	Vízkö van a hidr. rendszerben	Végezze el a vízköoldást a "11. Vízköoldás" fejezetben leírtak szerint.
	Túl finomra őrölt kávé	Vegye ki a szűrőtartó egységet (C1), ismételje meg a kávéfőző műveleteket a "4.1 1. szakasz - Őrlés (grinding)" és "4.2 2. szakasz - Tömörítés (tamping)" bekezdések figyelembevételével
A szűrőtartót nem lehet ráakasztani a készülékre	Az őrölt kávé nem lett tömörítve vagy túl sok	Ismételje meg a kávédarálást eltérő beállításokkal. Csökkentse az adag mennyiségét: ellenőrizze, hogy a (C2) vagy (C3) szűrő (1 vagy 2 csésze) megfelel-e az őröndő adagnak (2x gomb (B3) ki van-e választva vagy sem)
Az espresso kávé nem a szűrőtartó (C1) lyukain keresztül, hanem a szélén át csepeg	A szűrőtartó rosszul lett behelyezve	Akassza be megfelelően a szűrőtartót, és erővel teljesen csavarja be
	A kávéadagoló (A18) tömítése elvesztette rugalmasságát vagy szennyezett	Cserélje ki a kávéadagoló tömítését egy szakaszvizsnél
	A (C2) vagy (C3) szűrő eltömődött	Öblítse le a szűrőket folyó vízzel
A kávékrém világos színű (a kávé gyorsan folyik le a csőrből)	Meg kell vizsgálni a készülék beállításait	Vegye ki az egységet, ismételje meg a kávéfőző műveleteket a "4.1 1. szakasz - Őrlés (grinding)" és "4.2 2. szakasz - Tömörítés (tamping)" bekezdések szerint
		→

PROBLÉMA	OK	MEGOLDÁS
A kávékrém sötét színű (a kávé lassan folyik le a csőrből)	Meg kell vizsgálni a készülék beállításait	Vegye ki a szűrőtartó egységet (C1), ismétlje meg a kávéfőző műveleteket a „4.1 1. szakasz - Őrlés (grinding)” és „4.2 2. szakasz - Tömörítés (tamping)” bekezdések figyelembevételével
A vízköoldás végeztével a készülék egy újabb öblítést igényel	Az öblítési ciklus közben a tartály nem töltődött fel a MAX szintig	Ismétlje meg az öblítést (lásd a “11. Vízköoldás” fejezetet)
A készülék nem darál kávé	Idegen test került a kávédaráló belsejébe	Tisztítsa meg a darálókat a „8.3 A darálók tisztítása” bekezdésben leírtak szerint, győződjön meg arról, hogy eltávolította az összes kávészemet a szemes kávé tartóból (A2) annak kivétele előtt. Mielőtt visszatenné a darálót, gondosan távolítson el minden maradékot a fészkekből
	A szemes kávé tartó (A2) nincs a megfelelő helyzetben	A tartály megfelelően van behelyezve, ha a ▲ nyíl a ☐ szimbólumhoz igazodik, és „kattanást” hall
Amennyiben más minőségű kávé szeretne használni	El kell távolítani a gépben lévő összes kávészemet	<ul style="list-style-type: none"> • Űritse ki a szemes kávé tartót (A2) (végezzen üres járatban őrléseket vagy szükség esetén szívja el a maradék szemeket) • Akassza be a szűrőtartó egységet (C1) és végezzen több őrlést „üres” járatban, hogy szabaddá tegye a kávé csövet: akassza a szűrőtartót a kávédaráló kimenetére (A19) egy vonalba állítva az INSERT felirattal és a szűrőtartót forgassa el jobbra. Az őrlés akkor veszi kezdetét, amikor a kar eléri a CLOSE pozíciót és automatikusan félbeszakad. Ismétlje meg, amíg a szűrő üres nem lesz • Tegye a tartóba (A2) az új fajtájú szemes kávé • Ha a daráláskor nem éri el a „tökéletes adagot”, járjon el úgy, mint a legelső használatkor
		→

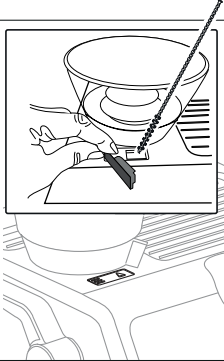
PROBLÉMA	OK	MEGOLDÁS
<p>Az őrlést követően a (C2) vagy (C3) kávé szűrő üres</p> <p>Őrlés után nagy mennyiségű kávépor van a szűrőben</p>	<p>A kávédaráló kávé csúszdája el van tömődve</p>	<p>Végezze el a tisztítást a „8.5 A „Smart tamping station” tisztítása” bekezdésben leírtak szerint. Ha a probléma továbbra is fennáll, nyissa ki a csúszda fedelét (A21) és a tisztító kefével szabadítsa fel a csúszdát</p> 
<p>A darálás után az őrlött kávé a (C2) vagy (C3) szűrőben nem éri el a „tökéletes adagot”</p>	<p>A „Smart Tamping Station”-t meg kell tisztítani</p> <p>Be kell állítani az őrlött kávé mennyiségét</p> <p>Idővel a darálók elkopnak</p>	<p>Végezze el a tisztítást a „8.5 A „Smart tamping station” tisztítása” bekezdésben leírtak szerint, majd ismétlje meg az őrlést</p> <p>Szabályozza a mennyiséget az e célt szolgáló szabályozógombbal (B2) a „A „tökéletes adag” bekezdésben leírt utasítások szerint. Ha a gomb már a max állásban van, a „7. Beállítások menü” - „A kávédaráló extra beállítása” szakaszban leírtak szerint járjon el</p> <p>Cserélje ki a darálókat a „8.4 Darálók cseréje” bekezdésben leírtak szerint.</p>

Před použitím přístroje si vždy přečtete příručku s bezpečnostními upozorněními.

1. POPIS

1.1 Popis přístroje - A

- A1. Víko zásobníku na kávová zrna
- A2. Zásobník na kávová zrna
- A3. Odkládací prostor na šálky
- A4. Otočný knoflík na páru
- A5. Dávkovač horké vody
- A6. Trubička dávkovače páry
- A7. Odkládací mřížka pro šálky na espresso
- A8. Odkládací mřížka pro sklenice nebo hrnky
- A9. Mřížka misky
- A10. Odkapávací miska
- A11. Ukazatel hladiny vody v odkapávací misce
- A12. Víko nádržky na vodu
- A13. Držadlo pro vyjmutí nádržky na vodu
- A14. Nádržka na vodu
- A15. Uložení změkčovacího filtru
- A16. Uložení konektoru napájecího kabelu
- A17. Hlavní vypínač (ON/OFF)
- A18. Dávkovač kávy
- A19. Výstup mlýnku kávy (Tamping station)
- A20. Páčka pěchovadla
- A21. Dvířka pro přístup ke kartáčku mlýnku na kávu

1.2 Popis ovládacího panelu - B

- B1. Tlačítko ON/Standby
- B2. Regulační knoflík množství mleté kávy
- B3. Tlačítko „X2“: pro použití filtru 2 kávy
- B4. Tlačítko „teplota kávy“
- B5. Tlačítko „OK“: pro výdej nápoje/pro potvrzení
- B6. Tlačítko „výdej horké vody“
- B7. Tlačítko „My“: pro osobní nastavení množství nápoju
- B8. Otočný knoflík volby funkcí
 - Espresso
 - Americano
 - Káva
 - Odvápňení
- B9. Kontrolka „odvápňení“
- B10. Kontrolka „pára připravena“
- B11. Kontrolka „chybí zásobník na kávová zrna“
- B12. Kontrolka „úspora energie“
- B13. Kontrolka „Čištění“ (viz „8.1 Čištění dávkovače kávy“)
- B14. Kontrolka „prázdný zásobník na kávová zrna“
- B15. Kontrolka „nedostatek vody“
- B16. Kontrolka „pěchování“
- B17. Tlakoměr

1.3 Popis příslušenství - C

- C1. Miska držák filtru
- C2. Filtr 1 šálek
- C3. Filtr 2 šálky
- C4. Testovací proužek „Total Hardness Test“
- C5. Odvápňovací přípravek
- C6. Odnímatelný napájecí kabel
- C7. Kartáček
- C8. Příslušenství pro čištění dávkovače kávy
- C9. Softballs
- C10. Konvička na mléko
- C11. Jehla pro čištění parní trysky

1.4 Příslušenství k čištění nejsou součástí dodávky, jsou doporučeny výrobcem

Další informace najdete na webu Delonghi.com.



Čistící tablety

(Viz „8.1 Čištění dávkovače kávy“)

 **Čistící prostředek**
EAN: 8004399333307

2. PŘÍPRAVA PŘÍSTROJE

Umyjte veškeré příslušenství teplou vodou a mycím prostředkem, a poté postupujte následovně:

1. Zasuňte zásobník na kávová zrna (A2) do mlýnku na kávu (obr. 1). Zásobník je zasunut správně, když je šipka ▲ zarovnaná se symbolem ☐ a je slyšet zacvaknutí (obr. 2).
2. Zasuňte tácek na odkapávání (A10) spolu s mřížkou na odkládání šálků (A8) a mřížkou misky (A9) (obr. 3);
3. Vyjměte nádržku na vodu (A14) (obr. 4) a naplňte ji čistou vodou, přičemž dávejte pozor, abyste nepřekročili nápis MAX (obr. 5).
4. Poté zasuňte zpět nádržku.

Pozor: Nikdy neuvádějte do provozu přístroj bez vody v nádržce nebo bez nádržky.

Poznámka: Doporučujeme co nejdříve provést nastavení tvrdosti vody podle postupu popsáno v kapitole „7. Menu nastavení“.

3. PRVNÍ UVEDENÍ PŘÍSTROJE DO PROVOZU

1. Zasuňte konektor napájecího kabelu (C6) do příslušného umístění (A16) na zadní straně přístroje (obr. 6); poté zasuňte zástrčku do zásuvky. Ubezpečte se, že hlavní vypínač (A17), umístěný na zadní straně přístroje, je stisknutý v poloze I (obr. 7);
2. Umístěte pod dávkovač horké vody (v úrovni dávkovače kávy (A18)) nádobu o minimálním objemu 100 ml (obr. 8);
3. Stiskněte tlačítko (B6) v úrovni kontrolky  (obr. 9): výdej se zahájí a automaticky přeruší. Nádobu vyprázdněte. Než začnete přístroj používat, je nutné vypláchnout jeho vnitřní okruhy. Postupujte následovně:

- Přípevněte misku držák filtru (C1) spolu s filtrem k přístroji: pro správné připevnění zarovnejte rukojeť držáku filtru se symbolem "INSERT" (obr. 10) a otočte rukojeť směrem doprava, až do zarovnání s polohou "CLOSE";
- Umístěte nádobu pod misku držák filtru a trubičku dávkovače páry (A6);
- Stiskněte tlačítko OK (B5) (obr. 11): spustí se výdej;
- Po dokončení výdeje otočte knoflíkem na páru (A4) (obr. 12) a několik vteřin vydávejte páru tak, aby se propláchl parní okruh: pro optimální výdej páry se doporučuje tento postup zopakovat 3 nebo 4krát. To umožní odstranit vodu z trubičky před výdejem páry.

Přístroj je tak připraven k použití.

Poznámka: *vypalování vnitřních okruhů je doporučeno také v případě delšího nepoužívání přístroje.*

Při prvním použití je nutné připravit 4-5 káv předtím, než přístroj začne podávat uspokojivý výsledek: věnujte zvláštní pozornost dávce mleté kávy ve filtru ((C2) nebo (C3)) (viz pokyny v odstavci „4.1 Krok 1 - Mletí (grinding)“).

Postupujte, jak je uvedeno v kapitole „Dokonalá dávka“.

4. PŘÍPRAVA KÁVY

4.1 Krok 1 - Mletí (grinding)

- Nasypte zrna do zásobníku (A2) (obr. 13). Doporučujeme nasypat pouze zrna nezbytná pro přípravu: tímto způsobem budete vždy používat čerstvou kávu;
- Vyberte stupeň mletí (obr. 14). Výchozí tovární nastavení je 5 (střední mletí). Pokud výsledek není uspokojivý, upravte stupeň podle vlastní chuti a druhu kávy (nastavení se provádí, když je mlýnek na kávu v provozu).

Poznámka: *Stupeň mletí mezi 3 a 6 je doporučený pro většinu káv. Výsledek mletí s výběrem na 1 nebo 2 je velmi jemný, lze jej použít pouze se speciální kávou (lehce praženou).*

- Vložte jeden z filtrů kávy (C2) nebo (C3) do držáku filtru (C1) (obr. 15). Pokud se používá filtr na 2 šálky, stiskněte tlačítko X2 (B3): tímto výběrem se zdvojnásobí také vydané množství espressa.
- Provedte nastavení knoflíku množství (B2) počínaje od minimální polohy (obr. 16).

Pro další pokyny nahlédněte do odstavce „Nastavení množství mleté kávy ve filtru“.

- Přípevněte misku držák filtru k výstupu mlýnku (A19) a zarovnejte jej s nápisem INSERT: poté otočte misku směrem doprava. Mletí je zahájeno, když se miska dostane do polohy CLOSE a automaticky se zastaví.

Nastavení množství mleté kávy ve filtru

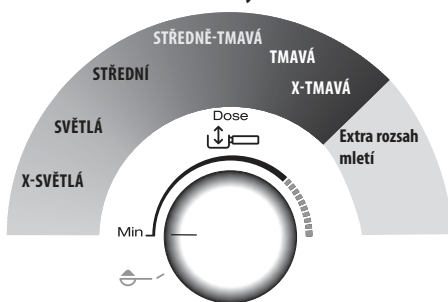

Každý druh zrna dává během mletí jiný výsledek, a proto je při úpravě dávky nutné zpočátku postupovat velmi opatrně.

Tento obrázek ukazuje, jak upravit dávku podle barvy pražení: je třeba je považovat za výchozí bod, ale mohou se lišit podle složení kávových zrn.

- Nastavte dávku z minimální polohy.
- Podle barvy pražení vaší kávy pomalu otáčejte knoflíkem.

4.2 Krok 2 - Pěchování (tamping)

- Po namletí sklopte pěchovací páčku (A20) až na doraz (neodstraňujte držák filtru) (obr. 17). Pro dokonalý výsledek zopakujte 2 krát.
- Při demontáži držáku filtru držte páčku skloněnou až na doraz (obr. 18). Poté uveďte páčku do výchozí polohy.
- Po ověření správné dávky kávy (viz „Dokonalá dávka“) zahákněte držák filtru k dávkovači kávy (A18) (obr. 19).

Poznámka: *Pokud po stlačení zůstanou zbytky kávy po okrajích filtru, nijak to neovlivní kvalitu extrakce a tím i konečný výsledek.*

„Dokonalá dávka“

- Kávové filtry mají vnitřní referenční značení pro určení dokonalé dávky.

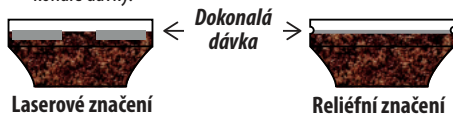

- Filtry s laserovým značením: dokonalá dávka odpovídá horní čáře značení;
- Filtry s reliéfním značením: dokonalá dávka odpovídá reliéfní linii;
- Ujistěte se, že je káva po upěchování zarovnaná. Může být nutná opakovaná regulace knoflíku (B2), než je dosaženo dokonalé dávky.
- Pokud je káva nadměrně nebo nedostatečně extrahována a dávka je v rámci dokonalé dávky, upravte stupeň hrubosti mletí na jemnější nebo hrubší (viz „4.1 Krok 1 - Mletí (grinding)“). Pokud je káva nadměrně extrahována (výdej příliš pomalý), mletí bude muset být hrubší. Pokud je káva

nedostatečně extrahována (výdej příliš rychlý), mletí bude muset být jemnější.

- **Barman doporučuje:** Vyjměte držák filtru, zatímco je páčka pěchovadla (A20) sklopená, abyste dosáhli dokonalého zakončení dávky kávy.
- **Pokud se používá předemletá káva:**
 - nasype předemletou kávu do filtru;
 - otočte knoflíkem na ;
 - zavěste držák filtru na výstup mlynku na kávu;
 - sklopte pěchovací páčku.













4.3 Krok 3 - Výdej (brewing)

1. Zvolte teplotu (obr. 20) (viz „Teplota pro přípravu kávy“).
2. Vyberte požadovaný nápoj (obr. 21).
3. Stiskněte OK (B5) pro zahájení výdeje (obr. 11) (před-spaření a spaření). Výdej kávy se automaticky přeruší.

Teplota pro přípravu kávy

Teplota vody je kontrolována během celého procesu přípravy, aby byla zajištěna její stabilita během extrakční fáze. La Specialista Prestigio nabízí 3 teploty spaření*, které odpovídají rozsahu mezi 92°C a 96°C.

V závislosti na odrůdě a pražení kávových zrn se doporučuje odlišná teplota: zrna Robusta vyžadují nízkou teplotu; zrna Arabica vysokou teplotu. Totéž platí pro tmavě pražená zrna nebo pro čerstvě upražená zrna.

Úroveň teploty	Odpovídající kontrolka	Stupeň pražení
MIN	   	tmavá
MED	   	středně-tmavá
MAX	   	světle - tmavá

* Tato teplota se vztahuje na vodu v termobloku. Liší se tedy od teploty nápoje v šálku nebo od teploty naměřené, když nápoj opouští dávkovače držáku filtru.

5. PŘÍPRAVA NÁPOJE S MLÉKEM

5.1 Napěnění mléka

1. Nalijte do konvičky (C10) množství mléka, které se má ohřát/napěnit, s ohledem na to, že se objem mléka zvýší dvakrát nebo třikrát (obr. 22). Pro získání hustší a homo-

genější pěny se doporučuje používat plnotučné kravské mléko mající teplotu z lednice (zhruba 5 °C).

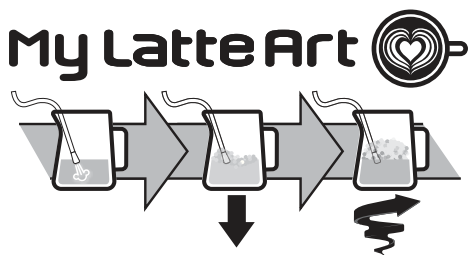

2. Pro napěnění mléka umístěte trubičku dávkovače páry (A6) na povrch mléka: tímto způsobem se vzduch mísí s mlékem a párou.
3. Udržte dávkovač páry na povrchu, a dávejte pozor, abyste nezachytili příliš mnoho vzduchu vytvořením příliš velkých bublin.
4. Ponořte dávkovač páry pod povrch mléka: tímto způsobem se vytvoří vír. Po dosažení požadované teploty zavřete otočný knoflík na páru a před vyjmutím konvičky na mléko počekajte, až se výdej páry zcela přeruší.

Barman doporučuje:

- **Lepsi je studené mléko.** Používejte vždy studené mléko z lednice.
- Pro lepší výsledek se doporučuje vždy umístit konvičku na mléko do lednice.
- Plnotučné mléko zajistí vynikající výsledky. Výsledek a struktura pěny se liší podle použitého kravského mléka nebo rostlinných nápojů.
- Po napěnění mléka odstraňte bubliny mírnou rotací konvičky na mléko.

Čištění dávkovače páry:

1. Po každém použití odstraňte zbytky mléka z dávkovače páry hadříkem (obr. 23). Pro hloubkové čištění je vhodné použít Eco MultiClean: zajišťuje hygienu odstraněním mléčných bílkovin a tuků a může být použit k čištění celého přístroje.
2. Vydávejte páru několik sekund, aby se dávkovač dobře vyčistil (obr. 12).
3. Počkejte, až dávkovač vychladne: pro udržení účinnosti dávkovače v průběhu času použijte čisticí jehlu (C11) tak, aby 3 otvory byly neustále volné (obr. 24).

6. PŘÍZPŮSOBENÍ MNOŽSTVÍ KÁVOVÝCH NÁPOJŮ TLAČÍTKEM (B7)

1. Připravte přístroj pro výdej 1 nebo 2 šálek požadovaného kávového nápoje až po zaháknutí držáku filtru (C1) vybaveného filtrem (C2) nebo (C3) a mletou kávou.
2. Otočte knoflíkem (B8) pro výběr nápoje určeného k naprogramování.

- Stiskněte tlačítko : kontrolka v úrovni tlačítka bliká.
 - Stiskněte tlačítko OK pro zahájení výdeje. Kontrolky odpovídající tlačítkům OK a blikají.
 - Jakmile dosáhnete požadovaného množství, stiskněte OK. Pokud nápoj předvidá výdej další přísady, zahájí se výdej druhé přísady: jakmile je dosaženo požadovaného množství, stiskněte OK.
 - Stiskněte tlačítko pro uložení. Přístroj je připraven k novému použití a kontrolka svítí.
- Pokud programování uložit nechcete, stiskněte jakékoliv jiné tlačítko.

Poznámka:

- Je možné naprogramovat nápoje s kávou, ale ne výdej páry a horké vody.
- Programování mění množství nápojů, ale ne mleté kávy.
- Nápoje „X2“ mohou být naprogramovány odděleně.
- Chcete-li se vrátit k továrnímu nastavení, podržte stisknuté tlačítko , dokud se nevy vypne. Vybraný nápoj se vrátí na výchozí množství.**

Kávový recept	Výchozí množství	Nastavitelné množství
Espresso	35 ml	od 25 do 90 ml
Espresso X2	70 ml	od 50 do 180 ml
Coffee	80 ml	od 50 do 120 ml
Coffee X2	160 ml	od 120 do 240 ml
Americano	120 ml	<ul style="list-style-type: none"> espresso: od 25 do 60 ml voda: od 25 do 120 ml
Americano X2	240 ml	<ul style="list-style-type: none"> espresso: od 50 do 120 ml voda: od 50 do 240 ml

7. MENU NASTAVENÍ

1. Vstupte do menu:		
Stiskněte současně po dobu 5 vteřin	x2	
2. Nastavení výběrem pomocí knoflíku (B8)		
→		

Odpovídající nastavení	Otočit na	Regulace
Extra nastavení mletí	Espresso	x2 → Rozsah 1
		→ Rozsah 2
Tvrdoost vody	Americano	x2 → měkká
		→ středně tvrdá
		→ tvrdá/velmi tvrdá
Automatické vypnutí	Coffee	x2 → 9 minut
		→ 1,5 hodiny
		→ 3 hodiny

3. Nastavení výběrem pomocí tlačítka:	
Úspora energie	→ Aktivní
	→ Vypnuto
Výchozí hodnoty	Držte stisknuté tlačítko po dobu nejméně 5 sekund, dokud kontrolka nezůstane rozsvícená
4. Uložte nová nastavení stisknutím ON/Standby (B1)	

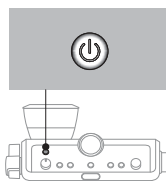

8. ČIŠTĚNÍ PŘÍSTROJE











Pozor!

- Na čištění přístroje nepoužívejte ředidla, abrazivní čistící prostředky nebo alkohol.
- Na odstraňování vodního kamene nebo kávových usazenin nikdy nepoužívejte kovové předměty, protože by mohlo dojít k poškrábání kovového nebo plastového povrchu.
- Pokud přístroj nepoužíváte déle než týden, doporučuje se před použitím provést vyplachování.

Nebezpečí!



- Během čištění nedávejte nikdy přístroj do vody: je to elektrické zařízení.

- Před jakoukoli operací čištění vnějších částí přístroj vypněte, vytáhněte zástrčku ze zásuvky elektrického napětí a nechte jej vychladnout.

					
	✗	✓	✓	✗	✗
	✓	✗	✗	✓	✓
	✗	✗	✗	✓	✓
	✗	✗	✗	✓	✓
	✗	✗	✓	✓	✗
	✗	✗	✗	✓	✓

8.1 Čištění dávkovače kávy



Když se kontrolka  rozsvítí (oranžová) (B13), je nutné vyčistit okruh kávy. Chcete-li spustit čistící cyklus, kupte si čistící tablety pro kávovary. Další informace najdete na webu www.Delonghi.com.

1. Vložte filtr 1 šálek (C2) do držáku filtru (C1) (obr. 25).
2. Vložte do filtru čistící příslušenství (C8) (obr. 25) a zatlačte jej na doraz.
3. Vložte čistící tabletu na příslušenství (obr. 26).
4. Připojte držák filtru k dávkovači kávy (A18).
5. Naplňte nádržku na vodu (A14). Zkontrolujte, zda je odkapávací miska (A10) prázdná.
6. Držte stisknuté tlačítko  (B6), dokud se nerozsvítí kontrolka  (B13). Po několika minutách se čištění automaticky přeruší.
7. Odstraňte držák filtru a čistící příslušenství.
8. Umyjte držák filtru a filtr pod tekoucí vodou.
9. Zasuňte zpět držák filtru a proveďte vyplachování stisknutím tlačítka  : doporučuje se vložit pod držák filtru nádobu.
10. Vyjměte a vyprázdněte odkapávací misku.

Poznámka:

Tento čistící cyklus lze spustit v jakémkoliv okamžiku stisknutím tlačítka  na několik vteřin. Chcete-li operaci zrušit, stiskněte tlačítko na 10 vteřin.

8.2 Čištění uložení zásobníku na kávová zrna

1. Ujistěte se, že je zásobník na kávová zrna (A2) prázdný. Případně proveďte několik mletí naprázdno.
2. Vyhákněte zásobník jeho otočením proti směru hodinových ručiček a vyjměte ji z kávovaru (obr. 27)
3. Vysajte zbytky kávy (obr. 28).
4. Očistěte uložení zásobníku na kávová zrna vlhkým hadříkem a osušte (obr. 29);
5. Vložte zásobník zpět do mlýnku na kávu. Zásobník je zasunut správně, když je šípka  zarovnaná se symbolem  a je slyšet zacvaknutí (obr. 30).

8.3 Čištění mlecích kamenů

Při čištění zásobníku na kávová zrna (A2) očistěte uložení nádoby a horní mlecí kámen vlhkým hadříkem. Pro vyjmutí a výměnu mlecích kamenů se obraťte na servisní středisko.

Mlecí kámen lze vyjmout, pokud je zablokovan cizím tělesem. Pokud k tomu dojde, vyjměte zásobník na kávová zrna a postupujte následovně:

1. Zahákněte misku držák filtr (C1) a proveďte mletí "naprázdno" pro uvolnění kávového potrubí.
2. Vypněte přístroj.
3. Otočte proti směru hodinových ručiček regulátor mletí až na doraz, do polohy "REMOVE" (obr. 31).
4. Vyjměte horní část mlecího kamene uchopením za příslušnou rukojeť (obr. 32).
5. Mlecí kámen vyčistěte štětečkem (obr. 33) a zbytky kávy odsajte vysavačem (obr. 28).

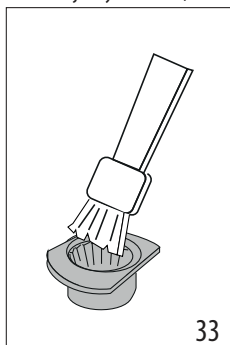

33

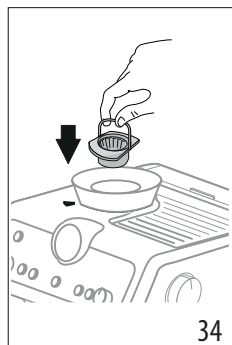

34

6. Vložte mlecí kámen na své místo (obr. 34);
 7. Otočte regulátorem pro zvolení požadovaného stupně hrubosti mletí (obr. 14);
- Ověřte, zda je mlecí kámen dobře zasunutý, tím že zatáhnete za jeho rukojeť: mlecí kámen je správně vložený, pokud se nepohne.

8.4 Výměna mlecích kamenů

Když se množství mleté kávy dále sníží, obraťte se na servisní středisko ohledně výměny mlecích kamenů: poté mlýnek znovu seřídte tak, že vstoupíte do menu nastavení („7. Menu nastavení“) a vyberete první rozsah extra regulace mletí. Poté otočte knoflíkem pro regulaci množství (B2) do polohy MIN a upravte dávku jako při prvním použití (viz „„Dokonalá dávka““).

8.5 Čištění „Smart tamping station“



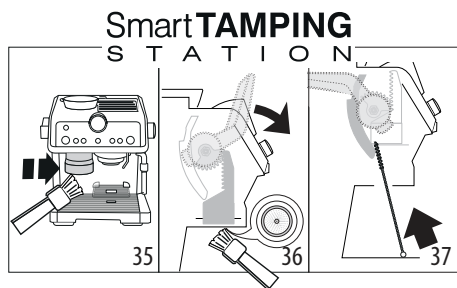

1. Vyčistěte oblast zaháknutí pomocí štetceku (obr. 35).
2. Zatáhněte za páčku (A20) až na doraz a štetčkem vyčistěte přechovač (obr. 36), poté páčku uvolněte.
3. Použitím kartáčku (C7) vyčistěte skluz kávy (obr. 37).



9. TVRDOT VODY

Kontrolka  (B9) odvápnění se zapne po předem stanovené době provozu, která závisí na tvrdosti vody. Podle potřeby je možné přístroj naprogramovat podle skutečné tvrdosti vody používané v různých oblastech a snížit tak interval odvápnění.

1. Vyměňte z obalu dodaný testovací proužek „TOTAL HARDNESS TEST“ (C4).
2. Přibližně na jednu sekundu ponořte celý proužek do sklenice s vodou.
3. Vytáhněte proužek z vody a lehce jím zatřepejte. Nastavte přístroj, jak je označeno v kapitole „7. Menu nastavení“.

Výsledek testu tvrdosti vody	Tlačítko	Stupeň
	×2	1 měkká voda
	≡ 0 ^o	2 středně tvrdá voda
	⊙ OK	3 tvrdá nebo velmi tvrdá voda
		

4. Nastavte přístroj, jak je označeno v kapitole „7. Menu nastavení“.

10. JAK POUŽÍVAT SOFTBALLS

Softballs (C9) je inovativní systém, který prodlužuje životnost přístroje, aniž by změnil kvalitu vody, a zajišťuje výdej krémové a aromatické kávy. Pro optimalizaci účinnosti nechte Softballs před použitím po celou noc ve vodě.

1. Vyměňte sáček se Softballs z obalu (obr. 38).

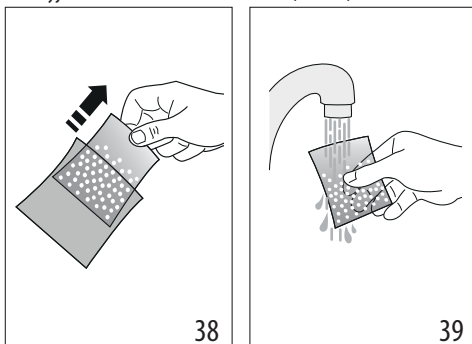

2. Propláchněte sáček se Softballs tekoucí vodou (obr. 39).
3. Ponořte sáček do nádržky na vodu (A14) (obr. 40).

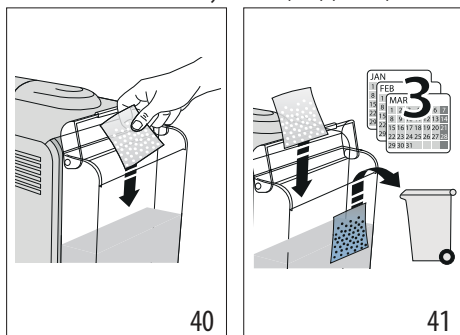

4. Vyměňte sáček se Softballs každé 3 měsíce (obr. 41).

11. ODVÁPŇNĚNÍ

Pozor!

- Před použitím si přečtěte pokyny a značení odvápnovacího přípravku (C5), uvedené na jeho obalu.
- Doporučujeme používat výhradně odvápnovací přípravek De'Longhi. Použití nevhodných odvápnovacích přípravků nebo nesprávné provádění odvápnění by mohly vést ke vzniku závad, na které se nevztahuje záruka výrobce.
- Odvápnovací přípravek může poškodit citlivé povrchy. Pokud dojde k náhodnému úniku produktu, okamžitě jej osušte.

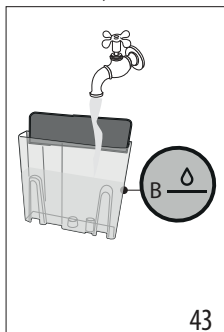
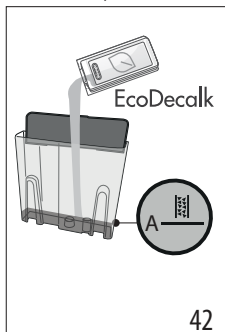

Pro provedení odvápňení	
Odvápňovací přípravek	Odvápňovací přípravek De'Longhi
Nádoba	Objem 2 litry
Doba	~40min

1. (POKUD JSOU K DISPOZICI, VYJMĚTE ZMĚKČOVACÍ FILTR A SOFTBALLS). Nalijte do nádrčky na vodu (A14) odvápnovací přípravek až do úrovně  A (odpovídají jednomu balení 100ml) vytlačené na vnitřní straně nádrčky (obr. 42).

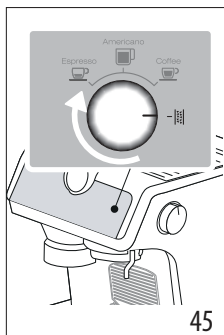
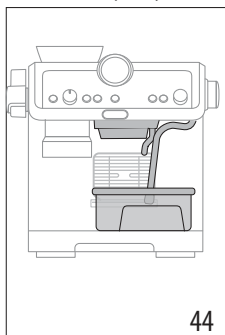

2. Přidejte vodu až do úrovně  B (obr. 43). Zasuňte zpět nádrčku na vodu do přístroje.



3. Ujistěte se, že držák filtru (C1) není zaháknutý a umístěte nádobu pod dávkovače kávy a horké vody, a pod dávkovač páry (A6) (obr. 44).
4. Otočte knoflíkem (B8) na  (obr. 45): kontrolka OK se rozsvítí oranžově; kontrolka  bliká.
5. Stiskněte tlačítko OK: kontrolka OK bliká.
6. Spustí se odvápnovací program a z dávkovačů vyteče odvápnovací kapalina. Program odvápnění automaticky provede celou sérii vyplachování s přestávkami, aby se odstranily usazeniny vodního kamene uvnitř kávovaru až do kompletního vyprázdnění nádrčky.

Výdej se přeruší a kontrolka OK bude bílá. Je proto nutné pokračovat ve vyplachovacím cyklu:

7. Vyprázdněte nádobu použitou ke sběru odvápnovacího roztoku a umístěte ji zpět pod dávkovače.
8. Vyjměte nádrčku na vodu, vyprázdněte ji od veškerých zbytků odvápnovacího roztoku, opláchněte ji pod tekoucí vodou a naplňte ji čerstvou vodou až do úrovně MAX (obr. 46). Poté nádrčku znovu zasuňte do jejího uložení.

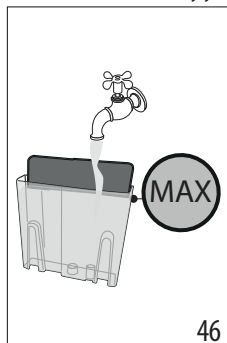





















9. Stiskněte tlačítko OK: spustí se vyplachování.
10. Po dokončení vyplachování se výdej přeruší a přístroj je připraven k použití.
11. Vyprázdněte sběrné nádoby oplachové vody.
12. Vyjměte a vyprázdněte odkapávací misku a znovu ji zasuňte.
13. Vyjměte a naplňte nádrčku čerstvou vodou a znovu ji zasuňte. Nyní je přístroj připraven k použití.





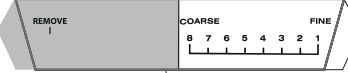
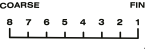

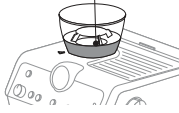

Poznámka:

- Cyklus odvápnění lze spustit v jakémkoliv okamžiku (i když příslušná kontrolka ještě nesvítí).
- Pokud bylo odvápnění spuštěno omylem, stiskněte tlačítko OK na 10 vteřin; vyplachování nelze přerušit.



12. VÝZNAM KONTROLEK

KONTROLKY	VÝZNAM KONTROLEK	ÚKON
Všechny kontrolky krátce blikají	Zapnutí přístroje	Autodiagnostika
 svítí	Jedná se o první zapnutí přístroje a je nutné provést naplnění vodního okruhu	Postupujte, jak je označeno v kap. „3. První uvedení přístroje do provozu“
 svítí (bílá) <ul style="list-style-type: none"> Kontrolka  : označuje teplotu vybrané kávy Kontrolka  : označuje, že je přístroj připraven k výdeji horké vody 	Kávovar je připraven k výdeji	Připravte kávovar a přistupte k přípravě nápoje
 svítí	Funkce úspory energie je aktivní	Pro deaktivaci funkce odkazujeme na kap. „7. Menu nastavení“
 svítí	Zásobník na kávová zrna (A2) je prázdný	Naplňte zásobník na kávová zrna
 bliká	Pokud chcete pokračovat v mletí, ale zásobník na kávová zrna (A2) je prázdný	Naplňte zásobník na kávová zrna
 krátce bliká v pravidelných intervalech	Knoflík (B2) je otočený do polohy maximální regulace 	Pokud je po mletí káva ve filtru nedostatečná, vyberte nový rozsah mletí, jak je uvedeno v kapitole „7. Menu nastavení“.
 svítí	V nádržce (A14) není dostatek vody nebo nádržka na vodu není správně zasunuta	Naplňte nádržku nebo ji vyjměte a znovu zasuňte
 bliká	Chcete-li pokračovat v přípravě nápoje, ale nádržka na vodu (A14) je prázdná	Naplňte nádržku na vodu
	Namletí je příliš jemné a káva tedy vytéká pomalu nebo vůbec.	Vyjměte misku držák filtru (C1), zopakujte kroky pro přípravu kávy s odkazem na pokyny v odst. „4.1 Krok 1 - Mletí (grinding)“ a „4.2 Krok 2 - Pěchování (tamping)“
	Kávový filtr (C2) nebo (C3) je ucpaný	Vypláchněte filtry pod tekoucí vodou
	Nádržka (A14) je špatně zasunutá a příslušné ventily nejsou otevřené	Lehce nádržku zatlačte tak, aby se otevřely ventily
 svítí	Vodní kámen v hydraulickém okruhu	Proveďte odvápnění, viz kap. „11. Odvápnění“
	Přístroj je připraven na výdej páry	Přístroj dosáhl teploty pro výdej páry. Chcete-li pokračovat ve výdeji, otočte knoflíkem na páru (A4)
		→

KONTROLKY	VÝZNAM KONTROLEK	ÚKON
 bliká	Přístroj je zapnutý a funkce úspory energie je aktivní: otočný knoflík na páru (A4) je v poloze pro výdej páry	Kontrolka bliká na znamení, že se přístroj připravuje na výdej páry: výdej se zahájí, jakmile přístroj dosáhne správnou teplotu
	Přístroj je připraven na výdej páry	Když kontrolka zůstane rozsvícená, dosáhl přístroj teplotu pro přípravu páry
	Přístroj vydává páru	
 svítí	Zásobník na kávová zrna není zasunutý	Zasuňte správně zásobník na kávová zrna (A2) nebo zkontrolujte, zda je správně zasunutý. Zásobník je zasunut správně, když je šipka ▲ zarovnaná se symbolem  a je slyšet zacvaknutí
 bliká	Nastavení voliče stupně mletí není správné nebo je nad maximálním možným nastavením	Uvedte volič do jedné z poloh mletí (mezi 1 a 8) a nezapomeňte: <ul style="list-style-type: none"> Regulovat mletí, když je mlýnek na kávu v provozu Provádět regulaci po jednotlivých stupních a vykonat nejméně 5 mletí mezi jednotlivými nastaveními
	<div style="display: flex; align-items: center; justify-content: space-between;"> <div style="text-align: center;"> <p>MIMO správný rozsah</p>  </div> <div style="text-align: center;">  </div> <div style="text-align: center;"> <p>Správný rozsah</p>  </div> </div> <div style="text-align: center; margin-top: 10px;">  </div>	
 svítí	Přístroj vyžaduje pēchování	Bylo právě provedeno pēchování a držák filtru je připojen ke kávovaru
	Držák filtru byl sejmut z mlýnku kávy, bez upēchování	Sejměte držák filtru a proveďte pēchování kávy podle popisu v odst. „„Dokonalá dávka““ „„Pokud se používá předemletá káva.““
	Držák filtru byl odpojen bez dokončení mletí nebo pēchování bylo provedeno příliš brzy	Opakujte mletí
	Skluz kávy mlýnku je ucpaný	Proveďte čištění, jak je označeno v odst. „8.5 Čištění „Smart tamping station““. Pokud problém přetrvává, přistupte ke žlábků otevřením příslušných dvířek a uvolněte jej pomocí kartáčku
	Mlecí kameny jsou blokovány cizím tělesem	Odstraňte cizí těleso a vyčistěte mlecí kameny, jak je uvedeno v odst. „8.3 Čištění mlecích kamenů“.
→		

KONTROLKY	VÝZNAM KONTROLEK	ÚKON
 svítí (červená)	Je třeba přistoupit k odvápnění	Provedte odvápnění, jak je zobrazeno v kap. „11. Odvápnění“
 bliká (červená) +  bliká (oranžová)	Přístroj provádí odvápnění	Pokračujte a dokončete operaci podle popisu v kap. „11. Odvápnění“
 bliká (červená) +  svítí (bílá)	Je nutné provést vyplachování	
 bliká (červená) +  bliká (bílá)	Přístroj provádí vyplachování odvápnovacího cyklu	
 svítí (oranžová)	Je nutné provést čištění dávkovače kávy	Viz odst. „8.1 Čištění dávkovače kávy“
 bliká (oranžová)	Přístroj provádí čištění dávkovače kávy	
Všechny kontrolky blikají	Všeobecný alarm	Obratě se na servisní středisko

13. POKUD NĚCO NEFUNGUJE

PROBLÉM	PŘÍČINA	ŘEŠENÍ
V odkapávací misce (A10) je voda	Jedná se o jev související s běžným provozem vnitřních okruhů přístroje	Pravidelně vyprazdňujte a čistěte odkapávací misku
Káva espresso nevytéká	Nedostatek vody v nádržce (A14)	Naplňte nádržku
	Kontrolka  (B6) svítí, což znamená, že okruh kávy nebo okruh páry je prázdný	Stiskněte tlačítko odpovídající kontrolce  pro naplnění okruhu
	Filtr (C2) nebo (C3) je ucpaný	Vypláchněte filtry pod tekoucí vodou
	Nádržka (A14) je špatně zasunutá a ventily na jejím dně nejsou otevřené	Lehce stiskněte nádržku, aby se otevřely ventily na jejím dně
	Vodní kámen v hydraulickém okruhu	Provedte odvápnění, viz kap. „11. Odvápnění“
	Příliš jemné namletí	Vyjměte misku držák filtru (C1), zopakujte kroky pro přípravu kávy s odkazem na pokyny v odst. „4.1 Krok 1 - Mletí (grinding)“ a „4.2 Krok 2 - Pěchování (tamping)“
Držák filtru nelze nasadit k přístroji	Mletá káva nebyla napěchována nebo je jí příliš mnoho	Opakujte mletí s různými nastaveními. Snižte množství dávky: zkontrolujte, zda je filtr (C2) nebo (C3) (1 nebo 2 šálky) správný pro dávku určenou k namletí (tlačítko 2x (B3) zvoleno nebo ne)
		→

PROBLÉM	PŘÍČINA	ŘEŠENÍ
Káva espresso vytéká z okrajů držáku filtru (C1) namísto z dírek	Držák filtru je špatně zasunutý	Umístěte správně držák filtru a otočte jím silou až na doraz
	Těsnění dávkovače kávy (A18) ztratilo pružnost nebo je znečištěné	Vyměňte těsnění dávkovače kávy v servisním středisku
	Filtr (C2) nebo (C3) je ucpaný	Vypláchněte filtry pod tekoucí vodou
Pěna kávy je světlá (vytéká rychle z hubice)	Je nutné zkontrolovat nastavení přístroje	Vyjměte misku, zopakujte kroky pro přípravu kávy s odkazem na pokyny v odst. „4.1 Krok 1 - Mletí (grinding)“ a „4.2 Krok 2 - Pěchování (tamping)“
Pěna kávy je tmavá (káva vytéká pomalu z hubice)	Je nutné zkontrolovat nastavení přístroje	Vyjměte misku držák filtru (C1), zopakujte kroky pro přípravu kávy s odkazem na pokyny v odst. „4.1 Krok 1 - Mletí (grinding)“ a „4.2 Krok 2 - Pěchování (tamping)“
Na konci odvápnění přístroj vyžaduje další vyplachování	Během cyklu vyplachování nebyla nádržka naplněna až po úroveň MAX	Zopakujte vyplachování (viz kap. „11. Odvápnění“)
Přístroj nemele kávu	Uvnitř mlýnku na kávu je cizí těleso	Provedte čištění mlecích kamenů, jak je označeno v odst. „8.3 Čištění mlecích kamenů“, přičemž se ujistěte, že jste odstranili všechna zrna ze zásobníku na kávová zrna (A2) před jeho vyjmutím. Před opětovným vložením mlecího kamene opatrně vysajte veškeré zbytky z jeho uložení
	Zásobník na kávová zrna (A2) není ve správné poloze	Zásobník je zasunut správně, když je šipka ▲ zarovnaná se symbolem ☐ a je slyšet zacvaknutí
Pokud si přejete změnit kvalitu kávy	Je nutné odstranit všechna zrna nacházející se v kávovaru	<ul style="list-style-type: none"> • Vyprázdněte zásobník na kávová zrna (A2) (provedením mletí naprázdno nebo případně zbylá zrna vysajte) • Připevněte misku držák filtru (C1) a proveďte mletí „naprázdno“ pro uvolnění vedení kávy: připevněte držák filtru na výstup mlýnku (A19) a zarovnejte jej s nápisem INSERT a otočte misku směrem doprava. Mletí je zahájeno, když se miska dostane do polohy CLOSE a automaticky se zastaví. Opakujte, dokud filtr nezůstane prázdný • Nasypte do zásobníku (A2) nový typ kávových zrn • Pokud během mletí není dosažena „dokonalá dávka“, postupujte jako při prvním použití
		→

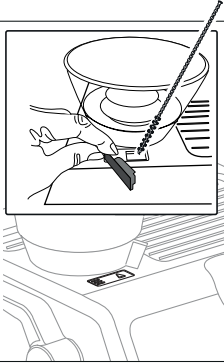
PROBLÉM	PŘÍČINA	ŘEŠENÍ
<p>Po mletí je kávový filtr (C2) nebo (C3) prázdný</p> <p>Po umletí je ve filtru nadměrné množství kávového prášku</p>	<p>Skuz kávy mlýnku je ucpaný</p>	<p>Provedte čištění, jak je označeno v odst. „8.5 Čištění „Smart tamping station““. Pokud problém přetrvává, přistupte ke žlábků otevřením příslušných dvířek (A21) a uvolněte jej pomocí kartáčku</p> 
<p>Po namletí kávový prášek ve filtru (C2) nebo (C3) nedosáhne „dokonalou dávku“</p>	<p>„Smart Tamping Station“ potřebuje vyčistit</p> <p>Množství mleté kávy musí být upraveno</p> <p>Časem se mlecí kameny opotřebují</p>	<p>Provedte čištění, jak je označeno v odst. „8.5 Čištění „Smart tamping station““, poté mletí zopakujte</p> <p>Nastavte množství pomocí příslušného knoflíku (B2) podle pokynů v odst. „„Dokonalá dávka““. Pokud je knoflík již v poloze max, postupujte podle pokynů v části „7. Menu nastavení“ - „Extra nastavení mletí“</p> <p>Provedte výměnu mlecích kamenů, jak je uvedeno v odst. „8.4 Výměna mlecích kamenů“</p>

Pred použitím zariadenia si vždy prečítajte bezpečnostné upozornenia.

1. OPIS

1.1 Opis spotrebiča - A

- A1. Veko zásobníka zrnkovej kávy
- A2. Zásobník zrnkovej kávy
- A3. Odkladacia plocha na šálky
- A4. Gombík pary
- A5. Vydávač horúcej vody
- A6. Hadička na vydávanie pary
- A7. Mriežka na šálky na espresso
- A8. Mriežka na poháre alebo hrnčeky
- A9. Mriežka odkvapkávacej misky
- A10. Odkvapkávacia miska
- A11. Indikátor hladiny vody v odkvapkávacej miske
- A12. Kryt nádržky na vodu
- A13. Rukoväť na vytiahnutie nádržky na vodu
- A14. Nádržka na vodu
- A15. Úložné miesto zmäčkovacieho filtra
- A16. Zásuvka na konektor napájacieho kábla
- A17. Hlavný vypínač (ON/OFF)
- A18. Vydávač kávy
- A19. Výstup kávového mlynčeka (Tamping station)
- A20. Páka presovača
- A21. Dvierka pre vstup do sklzu kávového mlynčeka

1.2 Opis ovládacieho panelu - B

- B1. Tlačidlo ON/Standby
- B2. Gombík nastavenia množstva mletej kávy
- B3. Tlačidlo „X2“: pre použitie filtra 2 káv
- B4. Tlačidlo „teplota kávy“
- B5. Tlačidlo „OK“: na nastavenie nápoja/potvrdenie
- B6. Tlačidlo „výdaj horúcej vody“
- B7. Tlačidlo „My“: na osobné nastavenie dĺžky nápojov
- B8. Gombík pre voľbu funkcií
 - Espresso
 - Americano
 - Káva
 - Odvápnenie
- B9. Kontrolka „odvápňovanie“
- B10. Kontrolka „para pripravená“
- B11. Kontrolka „chýba zásobník zrnkovej kávy“
- B12. Kontrolka „režim úspory energie“
- B13. Kontrolka „čistenie“ (pozri „8.1 Čistenie vydávača kávy“)
- B14. Kontrolka „prázdny zásobník zrnkovej kávy“
- B15. Kontrolka „nedostatok vody“
- B16. Kontrolka „presovanie“
- B17. Manometer

1.3 Opis príslušenstva - C

- C1. Držiak filtra
- C2. Filter 1 šálky
- C3. Filter 2 šálok
- C4. Reakčný prúžok „Total Hardness Test“
- C5. Odvápňovač
- C6. Napájací kábel odstrániteľný
- C7. Kefka
- C8. Príslušenstvo na čistenie vydávača kávy
- C9. Softballs
- C10. Kanvica na mlieko
- C11. Čistiaca ihla pre vydávanie pary

1.4 Príslušenstvo na čistenie nezahnuté, odporúčané výrobcom

Viac informácií nájdete na Delonghi.com.



Čistiace tablety

(Pozri „8.1 Čistenie vydávača kávy“)

 **Čistiaci prostriedok**
EAN: 8004399333307

2. PRÍPRAVA SPOTREBIČA

Všetko príslušenstvo umyte vlažnou vodou a prostriedkom na umývanie riadu a postupujte takto:

1. Založte zásobník zrnkovej kávy (A2) do kávového mlynčeka (obr. 1). Zásobník je založený správne, keď šípka ▲ je zarovnaná so symbolom ☪ a budete počuť „zakliknutie“ (obr. 2).
2. Vložte odkvapkávaciu misku (A10) spolu s mriežkou na šálky (A8) a mriežkou misky (A9) (obr. 3);
3. Vytiahnite nádržku na vodu (A14) (obr. 4) a naplňte ju čerstvou čistou vodou, dbajte na to, aby ste neprekročili značku MAX (obr. 5).
4. Potom vložte nádržku naspäť.

Pozor: Spotrebič nikdy neuvádzajte do prevádzky bez vody v zásobníku alebo bez zásobníka.

Poznámka: Odporúčame vám čo najskôr vykonať nastavenie tvrdosti vody podľa postupu opísaného v kapitole „7. Menu nastavení“.

3. PRVÉ UVEDENIE SPOTREBIČA DO PREVÁDZKY

1. Zasuňte konektor napájacieho kábla (C6) do príslušného miesta (A16) na zadnej strane spotrebiča (obr. 6); potom zasuňte zástrčku do elektrickej zásuvky. Uistite sa, že hlavný vypínač (A17), nachádzajúci sa v zadnej časti spotrebiča je v polohe I (obr. 7);
2. Pod vydávač horúcej vody (v súlade s vydávačom kávy (A18)) položte nádobu s minimálnym objemom 100 ml (obr. 8);
3. Stlačte tlačidlo (B6) vedľa kontrolky  (obr. 9): spustí sa výdaj a zastaví sa automaticky. Vyprázdňte nádobu.

Pred začatím používania spotrebiča je potrebné opláchnuť vnútorné obvody stroja. Postupujte takto:

4. Pripojte držiak filtra (C1) spolu s filtrom k spotrebiču: pre správne pripojenie zarovnaj te rukoväť držiaka filtra s „INSERT“ (obr. 10) a otočte rukoväť doprava, až kým nebude zarovnaná s polohou „CLOSE“;
5. Pod držiak filtra a k hadici vydávачa pary položte nádobu (A6);
6. Stlačte tlačidlo OK (B5) (obr. 11): výdaj sa začne;
7. Po dokončení výdaja otočte gombíkom pary (A4) (obr. 12) a niekoľko sekúnd vydávajte paru, aby sa prepláchol okruh pary: pre optimálny výdaj pary sa odporúča tento úkon zopakovať 3 alebo 4-krát. Tým sa umožní odstrániť vodu v hadici pred výdajom pary.

Spotrebič je teraz pripravený na použitie.

Poznámka: *prepláchnutie vnútorných okruhov sa odporúča aj po dlhšej dobe nečinnosti spotrebiča.*

Pri prvom použití je potrebné pripraviť 4-5 káv, až potom spotrebič začne dávať uspokojivý výsledok: osobitnú pozornosť venujte dávke mletej kávy vo filtrí ((C2) alebo (C3)) (pozri pokyny v odseku „4.1 Fáza 1 - Mletie (grinding)“).

Postupujte podľa pokynov v kapitole „Perfektná dávka“.

4. PRÍPRAVA KÁVY

4.1 Fáza 1 - Mletie (grinding)

1. Nasypete zrnká do zásobníka (A2) (obr. 13). Odporúča sa nasypať iba toľko zrníek, koľko je potrebných na prípravu: takto sa vždy použije čerstvá káva;
2. Zvoľte stupeň mletia (obr. 14). Nastavenie z výroby je 5 (stredné mletie). Ak by výsledok nebol uspokojivý, nastavte úroveň podľa osobnej chuti a podľa typu kávy (nastavenie sa vykonáva počas prevádzky kávového mlynčeka).

Poznámka: *Stupeň mletia medzi 3 a 6 sa odporúča pre väčšinu typov kávy. Výsledok mletia s voľbou na 1 alebo 2 je veľmi jemný, môže sa použiť iba s veľmi špeciálnou kávou (svetlé praženie).*

3. Vložte jeden z kávových filtrov (C2) alebo (C3) do držiaka filtra (C1) (obr. 15). Ak sa použije filter na 2 šálky, stlačte tlačidlo X2 (B3): touto voľbou sa zdvojnásobi aj vydaný počet kávy espresso.
4. Nastavte gombík množstva (B2) začínajúc od minimálnej polohy (obr. 16).

Odkazujeme na odsek „Nastavenie množstva mletej kávy vo filtrí“ pre ďalšie údaje.

5. Pripojte držiak filtra k výstupu kávového mlynčeka (A19) a zarovnaj ho s nápisom INSERT: potom držiak otočte doprava. Mletie sa spustí, keď sa držiak dostane do polohy CLOSE, a automaticky sa zastaví.

Nastavenie množstva mletej kávy vo filtrí



Každý typ zrníek dá počas mletia iný výsledok a z tohto dôvodu sa na začiatku nastavenia dávky vyžaduje mimoriadna pozornosť. Táto ilustrácia poskytuje informácie o tom, ako nastaviť dávku, na základe farby praženia: musí sa brať do úvahy východiskový bod, ale môže sa meniť na základe zloženia zrníek kávy.

1. Dávku nastavujte z minimálnej polohy.
2. Odkazujúc na farbu praženia vašej kávy, gombíkom pomaly otáčajte.

4.2 Fáza 2 - Presovanie (tamping)

1. Po namletí znížte presovaciu páku (A20) až na doraz (neodoberete držiak filtra) (obr. 17). Pre dokonalý výsledok zopakujte 2-krát.
2. Páku držte zníženú až na doraz počas odoberania držiaka filtra (obr. 18). Potom páku uveďte do počiatočnej polohy.
3. Po overení, či dávka kávy je správna (pozri „Perfektná dávka“), pripojte držiak kávy k vydávачu kávy (A18) (obr. 19).

Poznámka: *Ak aj po presovaní zostanú zvyšky kávy pozdĺž hrán filtra, to absolútne neznižuje kvalitu extrakcie a teda ani konečný výsledok.*

„Perfektná dávka“

- Filtry kávy majú vnútorné označenie na identifikáciu perfektnej dávky.



Laserové označenie

Reliéfové označenie

- Filtry s laserovým označením: perfektná dávka zodpovedá hornej čiare označenia;
 - Filtry s reliéfovým označením: perfektná dávka zodpovedá čiare v reliéfe;
- Uistite sa, či káva je po presovaní správne zarovnaná. Mohlo by byť potrebné viackrát nastaviť gombík (B2), kým sa nedostanete k perfektnej dávke.
 - Ak je káva pre-alebo podextrahovaná a dávka je v rámci perfektnej dávky, nastavte jemnejší alebo hrubší stupeň mletia (pozri „4.1 Fáza 1 - Mletie (grinding)“). Ak je káva

preextrahovaná (príliš pomalý výdaj), mletie bude musieť byť hrubšie. Ak je káva podextrahovaná (príliš rýchly výdaj), mletie bude musieť byť jemnejšie.

- **Barista odporúča:** Vytiahnite držiak filtra, kým je páka presovača (A20) znížená, aby ste dosiahli perfektnú povrchovú úpravu dávky kávy.
- **Ak používate mletú kávu:**
 - do filtra nasypete mletú kávu;
 - gombík otočte na ;
 - pripojte držiak filtra k výstupu kávového mlynčeka;
 - znížte presovaciu páku.



4.3 Fáza 3 - Výdaj (brewing)

1. Zvoľte teplotu (obr. 20) (pozri „Teplota na prípravu kávy“).
2. Zvoľte požadovaný nápoj (obr. 21).
3. Stlačte OK (B5) pre spustenie výdaja (obr. 11) (predvylúhovanie a vylúhovanie). Výdaj sa zastaví automaticky.

Teplota na prípravu kávy

Teplota vody sa kontroluje počas celého procesu prípravy, aby sa zaručila jeho stabilita vo fáze extrakcie. Model Specialista Prestigio ponúka 3 teploty vylúhovania*, ktoré zodpovedajú rozsahu medzi 92 °C a 96 °C.

Podľa druhu a praženia zrníek sa odporúča odlišná teplota: zrnká kávy Robusta si vyžadujú nízku teplotu; zrnká kávy Arabica vysokú teplotu. To isté platí pre zrnká s tmavým pražením alebo pre práve upražené zrnká.

Teplotná úroveň	Zodpovedajúca kontrolka	Stupeň praženia
MIN		Tmavé
MED		Stredne tmavé
MAX		Svetlo- Stredne tmavé

* Táto teplota sa týka vody v termobloku. Preto sa odlišuje od teploty nápoja v šálke alebo od teploty nameranej počas výtiekania nápoja z vydávačov držiaka filtra.

5. PRÍPRAVA NÁPOJOV S MLIEKOM

5.1 Napeňte mlieko

1. Do kanvice (C10) nalejte množstvo mlieka, ktoré chcete zohriať/napeniť, pričom berte do úvahy, že objem mlieka sa zdvojnásobí alebo strojnásobí (obr. 22). Aby ste získali hustejšiu

a homogénnejšiu penu, odporúča sa používať plnotučné kravské mlieko s teplotou z chladničky (približne 5 °C).

My Latte Art

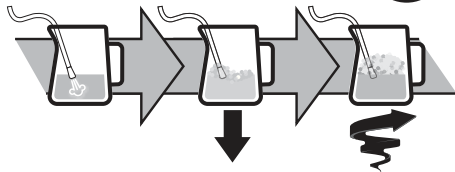

2. Pre napenenie mlieka priložte hadičku vydávača pary (A6) na povrch mlieka: tým sa vzduch vmieša do mlieka a do pary.
3. Vydávač pary ponechajte na povrchu, pričom dávajte pozor, aby ste nezachytili príliš veľa vzduchu, čím by sa vytvorili príliš veľké bubliny.
4. Vydávač pary ponorte pod povrch mlieka: takto sa vytvorí vír. Po dosiahnutí požadovanej teploty zatvorte gombík pary a počkajte, kým sa výdaj pary úplne neskončí, až potom odoberte kanvicu na mlieko.

Barista odporúča:

- **Čerstvé mlieko je najlepšie.** Vždy používajte čerstvé mlieko s teplotou, ktorú má v chladničke.
- Lepší výsledok dosiahnete, ak kanvicu na mlieko vždy znova odložíte do chladničky.
- Plnotučné mlieko zaistí najlepšie výsledky. Výsledok a textúra peny sa menia podľa použitého kravského mlieka alebo rastlinných nápojov.
- Po napnení mlieka odstráňte bubliny ľahkým krútením kanvice na mlieko.

Čistenie vydávača pary:

1. Po každom použití handričkou odstráňte zvyšky mlieka z vydávača pary (obr. 23). V prípade hĺbkového čistenia sa odporúča použiť Eco MultiClean: zabezpečí hygienu odstránením mliečnej bielkoviny a tukov a môže sa použiť na vyčistenie celého spotrebiča.
2. Niekoľko sekúnd vydávajte paru na dobré vyčistenie vydávača (obr. 12).
3. Počkajte, kým vydávač nevychladne: aby sa zachovala účinnosť vydávača v priebehu času, používajte čistiacu ihlu (C11) na to, aby 3 otvory zostali voľné (obr. 24).

6. PRISPÔBOBENIE DĹŽKY KÁVOVÝCH NÁPOJOV POMOCOU TLAČIDLA (B7)

1. Pripravte spotrebič na výdaj 1 alebo 2 šálok kávového nápoja, ktorý chcete pripraviť, a to až do bodu pripojenia držiaka filtra (C1) spolu s filtrom (C2) alebo (C3) a mletou kávou.

- Otočte gombík (B8) pre voľbu nápoja na naprogramovanie.
- Stlačte tlačidlo (my): kontrolka zodpovedajúca tlačidlu (my) bliká.
- Stlačte tlačidlo na spustenie výdaja. Kontrolky zodpovedajúce tlačidlám OK a (my) blikajú.
- Po dosiahnutí požadovaného množstva stlačte OK. Ak si nápoj vyžaduje výdaj ďalšej ingrediencie, najprv sa začne jej výdaj: po dosiahnutí požadovaného množstva stlačte OK.
- Stlačte tlačidlo (my) pre uloženie. Spotrebič je pripravený na nové použitie a kontrolka (my) zostane zapnutá.

Ak nechcete uložiť naprogramovanie, stlačte ľubovoľné iné tlačidlo.

Poznámka:

- Môžu sa naprogramovať kávové nápoje, ale nie výdaj pary a horúcej vody.
- Naprogramovaním sa zmenia množstvá nápojov, ale nie namletej kávy.
- Nápoje „X2“ sa môže naprogramovať samostatne.
- Pre návrat k nastaveniam z výroby podržte stlačené tlačidlo (my) až do vypnutia.** Zvolený nápoj sa vráti na množstvo z výroby.

Kávový recept	Množstvo z výroby	Naprogramovateľné množstvo
 Espresso	35 ml	od 25 do 90 ml
 Espresso X2	70 ml	od 50 do 180 ml
 Coffee	80 ml	od 50 do 120 ml
 Coffee X2	160 ml	od 120 do 240 ml
 Americano	120 ml	<ul style="list-style-type: none"> espresso: od 25 do 60 ml voda: od 25 do 120 ml
 Americano X2	240 ml	<ul style="list-style-type: none"> espresso: od 50 do 120 ml voda: od 50 do 240 ml



7. MENU NASTAVENÍ

1. Vstúpte do menu:

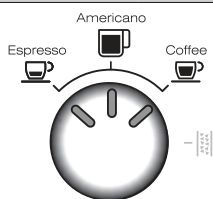

Súčasne stlačte na 5 sekúnd	x2	(my)
-----------------------------	----	------

2. Nastavenia s voľbou pomocou gombíka (B8)



Zodpovedajúce nastavenie	Otočte na	Regulácie
Nastavenie extra mletia	 Espresso	x2 ➔ Rozsah 1
		☰ ➔ Rozsah 2
Tvrdosť vody	 Americano	x2 ➔ mäkká
		☰ ➔ stredne tvrdá
		OK ➔ tvrdá/veľmi tvrdá
Automatické vypnutie	 Coffee	x2 ➔ 9 minút
		☰ ➔ 1,5 hodiny
		OK ➔ 3 hodiny

3. Nastavenia s voľbou pomocou tlačidla:

Úspora energie	 ➔ Aktívna
	 ➔ Vypnutá
Hodnoty z výroby	Podržte stlačené aspoň na 5 sekúnd tlačidlo (my), kým kontrolka nezostane zapnutá napevno

4. Nové nastavenia uložte stlačením ON/Standby (B1)

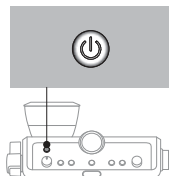











8. ČISTENIE SPOTREBIČA

Pozor!

- Na čistenie spotrebiča nepoužívajte rozpúšťadlá, drsné čistiace prostriedky, ani alkohol.
- Na odstraňovanie vodného kameňa alebo kávoových usadenín nikdy nepoužívajte kovové predmety, pretože by tak mohlo dôjsť k poškrabaniu kovového alebo plastového povrchu.
- V prípade obdobia nepoužívania dlhších ako jeden týždeň sa odporúča, pred použitím spotrebiča, vykonať preplachovanie.

Nebezpečenstvo!



- Počas čistenia nikdy neponárajte spotrebič do vody, je to elektrické zariadenie.
- Pred akýmkoľvek čistením vonkajších častí spotrebiča spotrebič najskôr vypnite, odpojte zástrčku od zásuvky a nechajte ho vychladnúť.

					
	×	✓	✓	×	×
	✓	×	×	✓	✓
	×	×	×	✓	✓
	×	×	×	✓	✓
	×	×	✓	✓	×
	×	×	×	✓	✓

8.1 Čistenie vydávača kávy

Keď sa kontrolka  zapne (oranžová) (B13), je potrebné vykonať čistenie okruhu kávy. Pre vykonanie cyklu čistenia si kúpte tablety na čistenie kávovaru. Viac informácií nájdete na www.Delonghi.com.



1. Vložte filter 1 šálky (C2) do držiaka filtra (C1) (obr. 25).
2. Do filtra vložte čistiace príslušenstvo (C8) (obr. 25) a zatlačte ho až na doraz.
3. Na príslušenstvo položte tabletu na čistenie (obr. 26).

4. Držiak filtra pripevnite k vydávaču kávy (A18).
5. Naplňte nádržku na vodu (A14). Uistite sa, či odkvapkávacia miska (A10) je prázdna.
6. Podržte stlačené tlačidlo  (B6), kým sa nezapne kontrolka  (B13). Po niekoľkých minútach sa čistenie automaticky preruší.
7. Vyberte držiak filtra a čistiace príslušenstvo.
8. Držiak filtra a filter umyte pod tečúcou vodou.
9. Znovu založte držiak filtra a vykonajte preplachovanie stlačením tlačidla  : odporúča sa pod držiak filtra položiť nádobu.
10. Odoberte a vyprázdňte odkvapkávaciu misku.

Poznámka:

Tento cyklus čistenia sa môže spustiť kedykoľvek stlačením tlačidla  na niekoľko sekúnd. Úkon zrušíte stlačením tlačidla na 10 sekúnd.

8.2 Vyčistite uloženie zásobníka zrnkovej kávy

1. Uistite sa, či zásobník zrnkovej kávy (A2) je prázdny. Eventuálne vykonajte niekoľko mletí naprázdno, aby ste ho vyprázdнили.
2. Odpojte zásobník otáčaním proti smeru otáčania hodinových ručičiek a vytiahnite ho zo spotrebiča (obr. 27)
3. Zvyšky kávy povysávajte (obr. 28).
4. Vlhkou handričkou vyčistite lôžko zásobníka zrnkovej kávy a osušte (obr. 29);
5. Znovu založte zásobník zasunutím do kávového mlynčeka. Zásobník je založený správne, keď šípka  je zarovnaná so symbolom  a budete počuť „zakliknutie“ (obr. 30).

8.3 Čistenie mlynčeka

Keď čistíte zásobník zrnkovej kávy (A2), vyčistite lôžko zásobníka a horný mlynček vlhkou handričkou. Pre odobratie a výmenu mlynčeka sa obráťte na asistenčné centrum.

Je možné odobrať mlynček v prípade, ak by kávový mlynček bol zablokovaný cudzím telesom. Ak by k tomuto došlo, odoberte zásobník zrnkovej kávy a postupujte nasledujúcim spôsobom:

1. Pripevnite držiak filtra (C1) a vykonajte mletie „naprázdno“, aby sa uvoľnilo vedenie pre kávu.
2. Spotrebič vypnite.
3. Regulátor mletia otočte v smere doľava úplne na doraz do polohy „REMOVE“ (obr. 31).
4. Vytiahnite hornú časť mlynčeka, pričom ju chyťte za príslušnú rukoväť (obr. 32).
5. Mlynček vyčistíte štetcom (obr. 33) a vysávačom povysávajte zvyšky kávy (obr. 28).

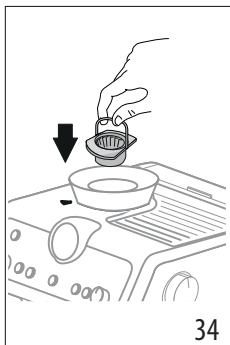
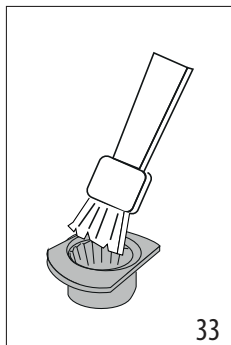

6. mlynček uložte na jeho miesto (obr. 34);
7. otočte gombík a vyberte požadovaný stupeň mletia (obr. 14);

potiahnutím za rukoväť overte, či je mlynček dobre zasunutý: je správne vložený, ak sa nehýbe.

8.4 Výmena mlynčekov

Keď sa množstvo namletej kávy ešte zníži, obráťte sa na asistenčné centrum za účelom výmeny mlynčekov: potom kávový mlynček znovu nastavte po vstupe do menu nastavení („7. Menu nastavení“) a zvolte prvý rozsah extra nastavenia mletia. Potom otočte gombík nastavenia množstva (B2) do polohy MIN a nastavte dávkou ako pri prvom použití (pozri „Perfektná dávka“).

8.5 Čistenie „Smart tamping station“

1. Vyčistite oblasť uchytenia pomocou kefy (obr. 35).
2. Potiahnite páku (A20) až na doraz a štetcom vyčistíte presovač (obr. 36), potom páku uvoľnite.
3. Pomocou kefy (C7) vyčistíte sklz kávy (obr. 37).

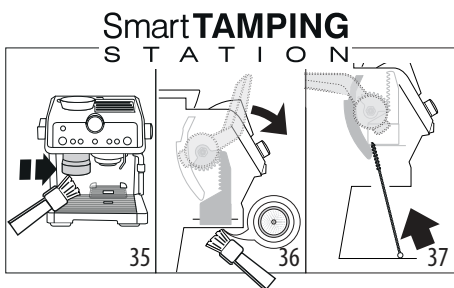

9. TVRDOŠŤ VODY

Kontrolka odvápnenia (B9) sa zapne po stanovenej dobe používania, ktorá závisí od tvrdosti vody. Spotrebič môžete naprogramovať v závislosti od skutočnej tvrdosti vody používanej v rôznych regiónoch a znížiť tak frekvenciu odvápnovania.

1. Vytiahnite z obalu testovacích prúžok „TOTAL HARDNESS TEST“ (C4).

2. Úplne ponorte prúžok do pohára vody asi na jednu sekundu.
3. Vytiahnite prúžok z vody a zľahka ním zatrasťte. Spotrebič nastavte podľa pokynov uvedených v kapitole „7. Menu nastavení“.

Výsledok testu tvrdosti vody	Tlačidlo	Úroveň
	×2	1 sladká voda
	≡ ⚡	2 stredne tvrdá voda
	⊙ OK	3 tvrdá alebo veľmi tvrdá voda

4. Spotrebič nastavte podľa pokynov uvedených v kapitole „7. Menu nastavení“.

10. AKO POUŽÍVAŤ SOFTBALLS

Softballs (C9) je inovatívny systém, ktorý predlžuje životnosť spotrebiča bez zmeny vlastností vody, pričom sa garantuje výdaj krémovej a aromatickej kávy. Pre optimalizáciu účinnosti nechajte Softballs vo vode na celú noc pred použitím.

1. Balík Softballs vytiahnite z obalu (obr. 38).

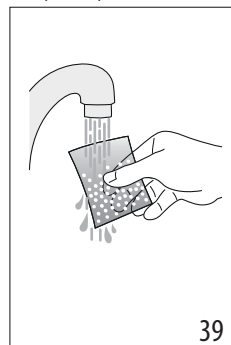
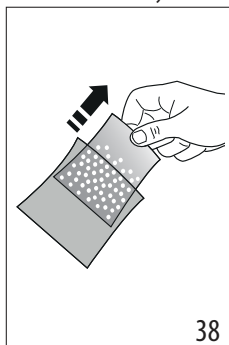

2. Balík Softballs prepláchnite pod tečúcou vodou (obr. 39).
3. Vrečko ponorte do nádrčky na vodu (A14) (obr. 40).

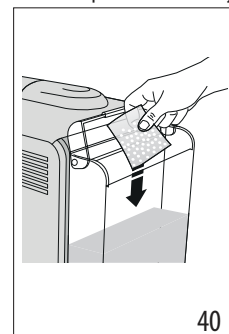

- Vrecko Softballs vymeňte každé 3 mesiace (obr. 41).

11. ODVÁPŇOVANIE

Pozor!

- Pred použitím si prečítajte pokyny a štítok na obale prípravku na odvápnenie (C5).
- Odporúča sa používať výhradne odvápnovacie prípravky De'Longhi. Použitie nevhodných odvápnovacích prípravkov rovnako ako nesprávne vykonané odvápnovanie môžu viesť k nezrovnalostiam, na ktoré sa nevzťahuje záruka výrobcu.
- Odvápňovač môže poškodiť jemné plochy. Ak sa prípravok náhodne prevráti, okamžite osušte.

Pre vykonanie odvápnovania	
Odvápňovač	Odvápňovač De'Longhi
Nádoba	Objem 2 litre
Čas	~40min

- (AK SA NACHÁDZA, ODOBERTE ZMÄKČOVACÍ FILTER A SOFTBALLS). Do nádržky na vodu (A14) nalejte odvápnovač až po rysku **A** (zodpovedá 100 ml baleniu) vytlačenú na vnútornej strane nádržky (obr. 42).

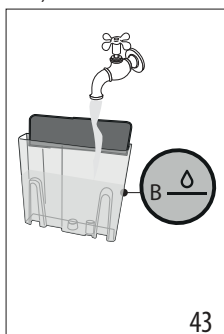
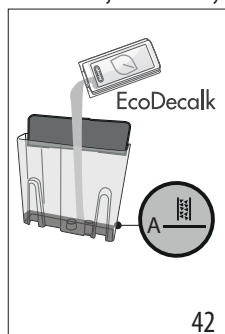

- Pridávajte vodu, kým nedosiahnete hladinu **B** (obr. 43). Potom nádržku na vodu znovu zasuňte do spotrebiča.

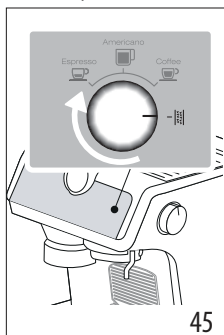
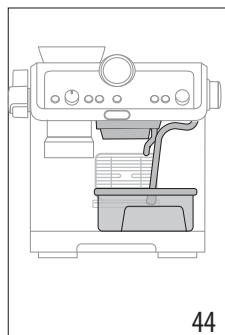

- Uistite sa, či držiak filtra (C1) nie je prípravený a pod vydávača kávy a horúcej vody a pod vydávača pary (A6) (obr. 44).
- Otočte gombík (B8) na (obr. 45): kontrolka OK sa zapne na oranžovo; kontrolka bliká
- Stlačte tlačidlo OK: kontrolka OK bliká.
- Program odvápnovania sa spustí a odvápnovacia tekutina vyteká z vydávačov. Program odvápnovania automaticky vykonáva celú sériu preplachovaní s prestávkami, aby sa odstránili usadeniny vodného kameňa vnútri kávovaru, až do vyprázdenia nádrže.

Výdaj sa preruší a kontrolka OK zmení farbu na bielu. Potom je potrebné vykonať preplachovací cyklus:

- Vyprázdnite nádobu, ktorú ste používali na zber odvápnovacej tekutiny, a umiestnite ju pod vydávača.
- Vyberte nádržku na vodu, vyprázdnite z nej všetky zvyšky odvápnovacieho roztoku, opláchnite ju tečúcou vodou a naplňte ju čerstvou vodou až do úrovne MAX (obr. 46). Potom nádržku vložte na jej miesto.

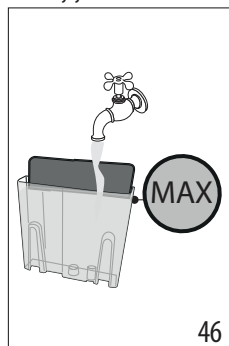













- Stlačte tlačidlo OK: spustí sa preplachovanie.
- Po dokončení preplachovania sa výdaj preruší a spotrebič je pripravený na použitie.
- Vyprázdnite oplachovú vodu zo zberných nádob.
- Vyberte a vyprázdnite odkvapkávaciu misku a potom ju znova vložte.
- Vyberte a naplňte nádržku čerstvou vodou a znovu ju vložte. Spotrebič je tak pripravený na použitie.





Poznámka:







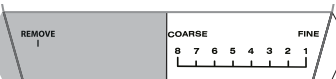
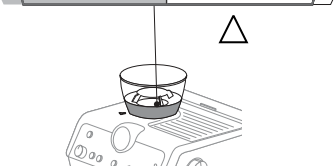



- Cyklus odvápnovania sa môže spustiť kedykoľvek (aj keď príslušná kontrolka nie je ešte zapnutá).
- V prípade, ak sa odvápnovanie spustilo omylom, stlačte tlačidlo na 10 sekúnd; preplachovanie sa nemôže prerušiť.

12. VÝZNAM KONTROLIEK



KONTROLKY	VÝZNAM KONTROLIEK	ÚKON
Všetky kontrolky krátko zablikajú	Zapnutie spotrebiča	Automatická diagnostika
 pevná	Je to prvé zapnutie spotrebiča a je potrebné naplniť vodný okruh	Postupujte podľa pokynov v kap. „3. Prvé uvedenie spotrebiča do prevádzky“
 pevná (biela) <ul style="list-style-type: none"> Kontrolka  signalizuje zvolenú teplotu kávy Kontrolka  : signalizuje, že spotrebič je pripravený na výdaj horúcej vody 	Spotrebič je pripravený na výdaj	Pripravte spotrebič a vykonajte prípravu nápoja
 pevná	Funkcia úspory energie je aktívna	Odkazujeme na kap. „7. Menu nastavení“ , ak chcete deaktivovať funkciu
 pevná	Zásobník zrnkovej kávy (A2) je prázdny	Naplňte zásobník zrnkovej kávy
 bliká	Chcete vykonať mletie, ale zásobník zrnkovej kávy (A2) je prázdny	Naplňte zásobník zrnkovej kávy
 bliká krátko v pravidelných intervaloch	Gombík (B2) je otočený do polohy maximálneho nastavenia 	Keď pomletí vo filtrí nie je dostatočné množstvo kávy, zvolte nový rozsah mletia podľa kapitoly „7. Menu nastavení“.
 pevná	Hladina vody v nádržke (A14) nie je dostatočná alebo nádržka na vodu nie je vložená správne	Naplňte nádržku alebo vyberte a znova správne vložte nádržku
 bliká	Chcete vykonať prípravu nápoja, ale nádržka na vodu (A14) je prázdna	Nádržku naplňte vodou
	Kávový mlynček melie príliš jemne, a preto káva vyteká veľmi pomaly alebo nevyteká vôbec.	Vyberte držiak filtra (C1), zopakujte operácie prípravy kávy, riadte sa pritom pokynmi v ods. „4.1 Fáza 1 - Mletie (grinding)“ a „4.2 Fáza 2 - Presovanie (tamping)“
	Kávový filter (C2) alebo (C3) je upchatý	Filtre prepláchnite pod tečúcou vodou
	Nádržka (A14) je nesprávne vložená a príslušné ventily nie sú otvorené	Jemne stlačte nádržku tak, aby sa ventily otvorili
 pevná	Vodný kameň vnútri hydraulického obvodu	Vykonajte odvápnenie podľa kapitoly „11. Odvápnovanie“
	Spotrebič je pripravený na výdaj pary	Spotrebič dosiahol teplotu na výdaj pary. Ak chcete vykonať výdaj, otočte rukoväť pary (A4)



KONTROLKY	VÝZNAM KONTROLIEK	ÚKON
 bliká	Spotrebič je zapnutý a funkcia úspory energie je aktívna: gombík pary (A4) je v polohe výdaja pary	Kontrolka bliká, čo znamená, že spotrebič sa pripravuje na výdaj pary: výdaj sa spustí, akonáhle spotrebič dosiahne príslušnú teplotu
	Spotrebič je pripravený na výdaj pary	Spotrebič dosiahol príslušnú teplotu na prípravu pary, keď kontrolka zostane pevná
	Spotrebič vydáva paru	
 pevná	Zásobník zrnkovej kávy nie je založený	Zásobník zrnkovej kávy založte správne (A2) alebo overte, či je správne založený. Zásobník je založený správne, keď šípka ▲ je zarovnaná so symbolom ☰ a budete počuť „zakliknutie“
 bliká	Nastavenie voliča stupňa mletia nie je správne alebo je mimo maximálneho možného nastavenia	Volič uveďte do jednej z polôh mletia (medzi 1 a 8), nezabudnite: <ul style="list-style-type: none"> • Mletie nastavte, kým je kávový mlynček v prevádzke • Nastavte zakaždým o jednu úroveň a urobte aspoň 5 mletí medzi jedným a druhým nastavením
	<div style="display: flex; align-items: center; justify-content: space-between;"> <div style="text-align: center;"> <p>MIMO rozsahu správny</p>  </div> <div style="text-align: center;"> <p>Rozsah správny</p>  </div> </div> <div style="text-align: center; margin-top: 10px;">  </div>	
→		

KONTROLKY	VÝZNAM KONTROLIEK	ÚKON
 svieti	Spotrebič vyžaduje presovanie	Práve bolo vykonané mletie a držiak filtra je pripravený k mlynčeku na kávu
	Držiak filtra bol vytiahnutý z mlynčeka na kávu bez stlačenia	Vytiahnite držiak filtra a pokračujte presovaním kávy, ako je popísané v ods. „Perfektná dávka“ „Ak používate mletú kávu:“
	Držiak filtra sa uvoľnil bez skončenia mletia alebo presovanie sa vykonalo príliš rýchlo	Zopakujte mletie
	Sklz kávy na kávovom mlynčeku je upchatý	Vykonajte čistenie podľa pokynov v ods. „8.5 Čistenie „Smart tamping station““. Ak problém pretrváva, dostaňte sa k sklzu otvorením príslušných dvierok a uvoľnite ho pomocou kefky
	Mlynček je zablokovaný cudzím telesom	Odstráňte cudzie teleso a mlynček vyčistite podľa pokynov v ods. „8.3 Čistenie mlynčekov“.
 pevná (červená)	Je potrebné vykonať odvápnovanie	Vykonajte odvápnenie podľa pokynov v kap. „11. Odvápnovanie“
 bliká (červená) +  bliká (oranžová)	Spotrebič vykonáva odvápnovanie	Pokračujte v dokončení operácie podľa pokynov v kap. „11. Odvápnovanie“
 bliká (červená) +  pevná (biela)	Je potrebné vykonať preplachovanie	
 bliká (červená) +  bliká (biela)	Spotrebič vykonáva preplachovanie počas cyklu odvápnovania	
 pevná (oranžová)	Je potrebné vykonať čistenie vydávača kávy	Pozri ods. „8.1 Čistenie vydávača kávy“
 blikajúca (oranžová)	Spotrebič vykonáva čistenie vydávača kávy	
Všetky kontrolky blikajú	Všeobecný alarm	Obráťte sa na asistenčné centrum

13. AK NIEČO NEFUNGUJE

PROBLÉM	PRÍČINA	RIEŠENIE
V odkvapkávacej misky je voda (A10)	Tvorí súčasť normálnej prevádzky z vnútorných okruhov spotrebiča	Odkvapkávaciu misku pravidelne vyprázdňte a vyčistite
Nevytéká káva espresso	Nedostatok vody v zásobníku (A14)	Nádržku naplňte
	Kontrolka  (B6) svieti, čím signalizuje, že okruh kávy alebo okruh pary je prázdny	Stlačte tlačidlo zodpovedajúce kontrolke  pre doplnenie okruhu
	Filter (C2) alebo (C3) je upchatý	Filtre prepláchnite pod tečúcou vodou
	Nádržka (A14) je nesprávne vložená a ventily na jej spodnej časti nie sú otvorené	Jemne stlačte nádržku tak, aby sa ventily na jej spodnej časti otvorili.
	Vodný kameň vnútri hydraulického obvodu	Vykonajte odvápnenie podľa kapitoly „11. Odvápnovanie“
	Mletie príliš jemné	Vyberte držiak filtra (C1), zopakujte operácie prípravy kávy, riadte sa pritom pokynmi v ods. „4.1 Fáza 1 - Mletie (grinding)“ a „4.2 Fáza 2 - Presovanie (tamping)“
Držiak filtra sa neuchytí na spotrebič	Namletá káva nebola stlačená presovačom alebo je v nadmernom množstve	Zopakujte mletie s inými nastaveniami. Znížte množstvo dávky: overte, či filter (C2) alebo (C3) (1 alebo 2 šálok) je správny vzhľadom k dávke na pomletie (tlačidlo 2x (B3) zvolené alebo nezvolené)
Káva espresso kvapká z okrajov držiaka filtra (C1) namiesto z otvorov	Držiak filtra je vložený nesprávne	Upevnite držiak filtra správne a silne ho zatočte až na doraz
	Tesnenie vydávača kávy (A18) stratilo pružnosť alebo je špinavé	Vymeňte tesnenie vydávača kávy v asistenčnom centre
	Filter (C2) alebo (C3) je upchatý	Filtre prepláchnite pod tečúcou vodou
Pena v káve je svetlá (káva vychádza rýchlo z ústia)	Je potrebné prehodnotiť nastavenia spotrebiča	Vyberte držiak, zopakujte operácie prípravy kávy, riadte sa pritom pokynmi v ods. „4.1 Fáza 1 - Mletie (grinding)“ a „4.2 Fáza 2 - Presovanie (tamping)“
Pena v káve je tmavá (káva pomaly vychádza z ústia)	Je potrebné prehodnotiť nastavenia spotrebiča	Vyberte držiak filtra (C1), zopakujte operácie prípravy kávy, riadte sa pritom pokynmi v ods. „4.1 Fáza 1 - Mletie (grinding)“ a „4.2 Fáza 2 - Presovanie (tamping)“
Po dokončení odvápnovania si spotrebič vyžaduje ďalšie preplachovanie.	Počas cyklu preplachovania nebola nádržka naplnená až po rysku MAX.	Preplachovanie zopakujte (pozri kap. „11. Odvápnovanie“)
		→

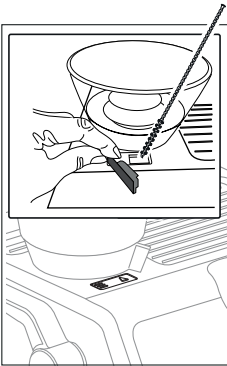
PROBLÉM	PRÍČINA	RIEŠENIE
Spotrebič nemelie kávu	Vnútri kávového mlynčeka sa nachádza cudzie teleso	Vykonajte čistenie mlynčekov podľa pokynov v ods. „8.3 Čistenie mlynčekov“ a uistite sa, že ste z neho pred odstránením zásobníka zrnkovej kávy (A2) odstránili všetky zrnká kávy. Skôr ako znovu vložíte mlynček, dôkladne povysávajte všetky zvyšky z jeho lôžka
	Zásobník zrnkovej kávy (A2) nie je v správnej polohe	Zásobník je založený správne, keď šípka ▲ je zarovnaná so symbolom ☞ a budete počuť „zakliknutie“
Ak si prajete zmeniť kvalitu kávy	Je potrebné odstrániť všetky zrnká kávy nachádzajúce sa v kávovare	<ul style="list-style-type: none"> • Vyprázdňte zásobník zrnkovej kávy (A2) (vykonaním mletí naprázdno alebo prípadne vysatím zvyšných zŕn). • Pripojte držiak filtra (C1) a vykonajte mletie „naprázdno“, aby sa uvoľnilo vedenie pre kávu: potom pripojte držiak filtra k výstupu kávového mlynčeka (A19) , zarovnajte ho s nápisom IN-SERT a otočte držiak doprava. Mletie sa spustí, keď sa držiak dostane do polohy CLOSE, a automaticky sa zastaví. Opakujte, dokým filter nezostane prázdny • Do zásobníka (A2) nasypete novú odrodu zrnkovej kávy • Ak sa pri mletí nedosiahne „perfektná dávka“, postupujte ako pri prvom použití
<p>Po mletí je kávový filter (C2) alebo (C3) prázdny</p> <p>Po zomletí je množstvo kávy vo filtri prebytočné</p>	Sklz kávy na kávovom mlynčeku je upchatý	<p>Vykonajte čistenie podľa pokynov v ods. „8.5 Čistenie „Smart tamping station““. Ak problém pretrváva, dostaňte sa k sklzu otvorením príslušných dvierok (A21) a uvoľnite ho pomocou kefy</p> 
		→

PROBLÉM	PRÍČINA	RIEŠENIE
Po mletí kávový prášok vo filtrí (C2) alebo (C3) nedosahuje „perfektnú dávku“	Je potrebné vyčistiť „Smart Tamping Station“	Vykonajte čistenie podľa pokynov v ods. „8.5 Čistenie „Smart tamping station“, potom zopakujte mletie
	Je potrebné nastaviť množstvo mletej kávy	Nastavte množstvo príslušným gombíkom (B2) podľa pokynov uvedených v ods. „„Perfektná dávka““. Ak gombík je už v polohe max, postupujte podľa pokynov uvedených v oddiele „7. Menu nastavení“ - „Nastavenie extra mletia“
	Používaním sa mlynčeky opotrebojú	Vykonajte výmenu mlynčekov podľa pokynov uvedených v ods. „8.4 Výmena mlynčekov“

Przed rozpoczęciem użytkowania, należy uważnie przeczytać broszurę, w której wskazano ostrzeżenia dotyczące bezpieczeństwa.

1. OPIS

1.1 Opis urządzenia - A

- A1. Pokrywa pojemnika na ziarna
- A2. Pojemnik na ziarna
- A3. Podstawa na filiżanki
- A4. Pokrętko pary
- A5. Dysza gorącej wody
- A6. Rurka wytwarzania pary
- A7. Kratka na filiżanki espresso
- A8. Kratka na filiżanki - szklanki lub kubki
- A9. Kratka tacki
- A10. Tacka na skropliny
- A11. Wskaźnik poziomu wody w tacce na skropliny
- A12. Pokrywa zbiornika na wodę
- A13. Uchwyt wyjmowania zbiornika na wodę
- A14. Zbiornik na wodę
- A15. Miejsce na filtr zmiękczejący
- A16. Gniazdo łącznika kabla zasilającego
- A17. Wyłącznik główny (ON/OFF)
- A18. Dozownik kawy
- A19. Wylot młynka (Tamping station)
- A20. Dźwignia praski
- A21. Otwór dostępu do prowadnika młynka do kawy

1.2 Opis panelu sterowania - B

- B1. Przycisk ON/Standby
- B2. Pokrętko regulacji ilości zmielonej kawy
- B3. Przycisk „X2”: do użycia filtra a 2 kawy
- B4. Przycisk „temperatura kawy”
- B5. Przycisk „OK”: przygotowanie napoju/potwierdzenie
- B6. Przycisk „wytwarzanie gorącej wody”
- B7. Przycisk „My”: personalizacja ilości napojów
- B8. Pokrętko wyboru funkcji
 - Espresso
 - Americano
 - Kawa
 - Odkamienianie
- B9. Kontrolka „odkamienianie”
- B10. Kontrolka „gotowa para”
- B11. Kontrolka „brak pojemnika na ziarna”
- B12. Kontrolka „oszczędność energetyczna”
- B13. Kontrolka „Czyszczenie” (patrz „8.1 Czyszczenie dozownika kawy”)
- B14. Kontrolka „pusty pojemnik na ziarna”
- B15. Kontrolka „brak wody”
- B16. Kontrolka „ubijanie”
- B17. Manometr

1.3 Opis akcesoriów - C

- C1. Łyżka uchwyty na filtr
- C2. Filtr na 1 filiżankę
- C3. Filtr na 2 filiżanki
- C4. Pasek kontrolny twardości wody „Total Hardness Test”
- C5. Odkamieniacz
- C6. Odłączany kabel zasilający
- C7. Wycior
- C8. Element czyszczenia dozownika kawy
- C9. Softballs
- C10. Dzbanek na mleko
- C11. Igła czyszczenia do lancy pary

1.4 Akcesoria do czyszczenia nie dołączone, zalecane przez producenta

Więcej informacji na stronie Delonghi.com.

Tabletki czyszczące

(Patrz „8.1 Czyszczenie dozownika kawy”)



 **EcoMultiClean Detergent**
EAN: 8004399333307

2. PRZYGOTOWANIE URZĄDZENIA

Wszystkie akcesoria umyć w letniej wodzie z płynem do naczyń, następnie:

1. Włożyć pojemnik na ziarna (A2) do młynka do kawy (rys. 1). Pojemnik jest włożony prawidłowo, gdy strzałka ▲ będzie wyrównana z symbolem ☐ i usłyszysz się „kliknięcie” (rys. 2).
2. Włożyć tackę na skropliny (A10) wraz z kratką na filiżanki (A8) i kratką tacki (A9) (rys. 3);
3. Wyjąć zbiornik na wodę (A14) (rys. 4) i napełnić go zimną i czystą wodą, uważając aby nie przekroczyć napisu MAX (rys. 5).
4. Ponownie włożyć zbiornik na miejsce.

Uwaga: Nigdy nie włączać urządzenia bez zbiornika lub, gdy nie ma w nim wody.

Zwróć uwagę: Zaleca się jak najszybsze ustawienie twardości wody zgodnie z procedurą opisaną w rozdziale „7. Menu ustawień”.

3. PIERWSZE WŁĄCZENIE URZĄDZENIA

1. Włożyć łącznik kabla zasilającego (C6) do odpowiedniego gniazda (A16) znajdującego się z tyłu urządzenia (rys. 6); następnie włożyć wtyczkę do gniazda. Upewnić się, że wyłącznik główny (A17), znajdujący się z tyłu urządzenia, jest wciśnięty na pozycji I (rys. 7);
2. Pod dyszą gorącej wody (w pobliżu dozownika kawy (A18)) ustawić pojemnik o minimalnej pojemności 100 ml (rys. 8);
3. Wcisnąć przycisk (B6) obok kontrolki  (rys. 9): rozpocznie się wytwarzanie wody, które zostanie przerwane automatycznie. Opróżnić pojemnik.

Przed rozpoczęciem użytkowania ekspresu, należy przepłukać jego wewnętrzne obwody. Należy postępować następująco:

4. Zaczepić łyżkę uchwyty na filtr (C1) wraz z filtrem w ekspresie: w celu prawidłowego zaczepienia, wyrównać rączkę łyżki z symbolem „INSERT” (rys. 10) i przekręcić uchwyt w prawo, aż do ustawienia na pozycji „CLOSE”;
5. Umieścić pojemnik pod łyżką uchwyty na filtr i rurką wytwarzania pary (A6);
6. Wcisnąć przycisk OK (B5) (rys. 11): rozpocznie się wytwarzanie;
7. Po zakończeniu wytwarzania, przekręcić pokrętko pary (A4) (rys. 12) i przez kilka sekund wytwarzać parę, aby wypłukać obwód pary: dla idealnego wytwarzania pary, zaleca się 3 lub 4-krotne powtórzenie takiej czynności. Umożliwi to usunięcie wody z rurki przed wytworzeniem pary.

Urządzenie jest gotowe do użycia.

Zwróć uwagę: *plukanie wewnętrznych obwodów jest zalecane również w przypadku długiego okresu niestosowania urządzenia.*

Przy pierwszym użyciu należy zaparzyć 4-5 kaw celem uzyskania zadowalającego efektu: zwrócić szczególną uwagę na dawkę kawy mielonej w filtrze ((C2) lub (C3)) (patrz instrukcje w paragrafie „4.1 Etap 1 - Mielenie (grinding)”).

Postępować jak wskazano w rozdziale „Idealna dawka”.

4. PRZYGOTOWANIE KAWY

4.1 Etap 1 - Mielenie (grinding)

1. Wsypać ziarna do pojemnika (A2) (rys. 13). Zaleca się wsypanie tylko niezbędnej ilości ziaren do przygotowania wybranego napoju: w ten sposób stosuje się zawsze świeżą kawę;
2. Wybrać stopień zmielenia (rys. 14). Ustawienie fabryczne wynosi 5 (średni stopień zmielenia). Jeżeli wynik nie będzie zadowalający, wyregulować poziom na podstawie osobistego smaku i rodzaju kawy (regulacji należy dokonać podczas działania młynka).

Zwróć uwagę: *Stopień zmielenia od 3 do 6 jest zalecany do większości typów kawy. Rezultatem mielenia ze stopniem 1 lub 2 jest bardzo drobna kawa, do użycia tylko w przypadku szczególnie-go typu kawy (jasno palona).*

3. Włożyć jeden z filtrów kawy (C2) lub (C3) do uchwyty na filtr (C1) (rys. 15). Jeżeli używa się filtra na 2 filiżanki, wcisnąć przycisk 2X (B3): takim wyborem podwaja się również ilość zaparzonej espresso.
4. Wyregulować pokrętko ilości (B2) poczynając od minimalnej pozycji (rys. 16).

Skonsultować paragraf „Wyregulować ilość kawy mielonej w filtrze” w celu uzyskania dodatkowych wskazówek.

5. Zaczepić uchwyt na filtr na wylocie młynka do kawy (A19) Zaczepić uchwyt na filtr na wylocie młynka do kawy. Miele-

nie rozpocznie się, gdy łyżka znajdzie się na pozycji CLOSE i zostanie przerwane automatycznie.

Wyregulować ilość kawy mielonej w filtrze

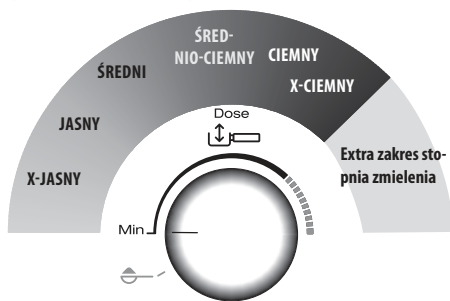

Każdy rodzaj ziaren daje inny rezultat podczas mielenia i z tego powodu, na początku regulacji dawki jest wymagana szczególna uwaga.

Ilustracja przedstawia wskazówki na temat sposobu regulacji dawki, w zależności od koloru palenia: należy je zastosować jako punkty wyjściowy, ale mogą się zmieniać w zależności od składu ziaren kawy.

1. Ustawić dawkę na minimalnej pozycji.
2. Odnosząc się do koloru palenia stosowanej kawy, powoli obrócić pokrętko.

4.2 Etap 2 - Ubijanie (tamping)

1. Po zmieleniu obniżyć do końca dźwignię ubijania (A20) (nie wyjmować uchwyty na filtr) (rys. 17). Powtórzyć 2 razy dla uzyskania idealnego rezultatu.
2. Podczas wyjmowania uchwyty na filtr, utrzymywać dźwignię obniżoną do ogranicznika (rys. 18). Następnie ustawić dźwignię na pozycji wyjściowej.
3. Po upewnieniu się że dawka kawy jest prawidłowa (patrz „Idealna dawka”), zaczepić uchwyt filtra na dozowniku kawy (A18) (rys. 19).

Zwróć uwagę: *Ewentualne resztki kawy pozostałe po ubijaniu na krawędziach filtra, pod żadnym względem nie wpływają na jakość parzenia i w związku z tym na końcowy rezultat.*

„Idealna dawka”

- Filtry kawy posiadają wewnętrzne oznaczenie, określające idealną dawkę.



- Filtry z oznaczeniem laserowym: idealna dawka od-powiada górnej linii oznaczenia;
- Filtry z oznaczeniem wypukłym: idealna dawka od-powiada wypukłej linii;

- Upewnić się, że po ubiciu kawa znajduje się na poziomie. Przed uzyskaniem idealnej dawki, może się okazać konieczne kilkukrotne wyregulowanie pokrętką (B2).
- Jeżeli ekstrakcja kawy jest zbyt słaba lub zbyt mocna, a dawka znajduje się w zakresie idealnej dawki, wyregulować drobniejszy lub grubszy stopień zmielenia (patrz „4.1 Etap 1 - Mielenie (grinding)”). Jeżeli ekstrakcja kawy jest zbyt mocna (wytwarzanie zbyt wolne), stopień zmielenia musi być grubszy. Jeżeli ekstrakcja kawy jest zbyt słaba (wytwarzanie zbyt szybkie), stopień zmielenia musi być drobniejszy.
- **Barman radzi:** Wyjąć uchwyt na filtr gdy dźwignia praski (A20) jest opuszczona w celu uzyskania idealnego wykonczenia dawki kawy.
- **W przypadku stosowania kawy mielonej:**
 - wysypać kawę mieloną do filtra;
 - ustawić pokrętkę na ;
 - zacześć uchwyt na filtr na wylocie młynka do kawy;
 - Obniżyć dźwignię ubijania.



4.3 Etap 3 - Parzenie (brewing)

1. Wybrać temperaturę (rys. 20) (patrz „Temperatura przygotowania kawy”).
2. Wybrać żądany napój (rys. 21).
3. Wcisnąć OK (B5), aby rozpocząć parzenie (rys. 11) (wstępne parzenie i parzenie). Wytwarzanie kawy zostanie przerwane automatycznie.

Temperatura przygotowania kawy

Temperatura wody jest kontrolowana podczas całego cyklu procesu przygotowywania w celu zagwarantowania stabilności na etapie ekstrakcji. Specjalista Prestigio oferuje 3 temperatury parzenia*, które odpowiadają zakresowi od 92° do 96°C.

W zależności od rodzaju i palenia ziaren zaleca się różną temperaturę: ziarna Robusta wymagają niskiej temperatury; ziarna Arabica wysokiej. Dotyczy to również ziaren o ciemnym kolorze palenia lub ziarna palone.

Poziom temperatury	Odpowiadająca kontrolka	Poziom palenia
MIN.		ciemny
ŚRED.		Średnio-ciemny
MAKS.		Jasno - ciemny

- * Taka temperatura odnosi się do wody w thermoblock. Jest więc różna od temperatury napoju w filiżance lub od temperatury zmierzonej, gdy napój wypływa z dysz uchwytu na filtr.

5. PRZYGOTOWYWANIE NAPOJÓW MLECZNYCH

5.1 Spienić mleko

1. Włączyć do dzbanka (C10) ilość mleka, które chce się podgrzać/spienić, pamiętając, że objętość mleka zwiększy się 2 lub 3 razy (rys. 22). Aby uzyskać bardziej gęstą i obfitą piankę, powinno się używać krowiego mleka z lodówki (około 5° C).

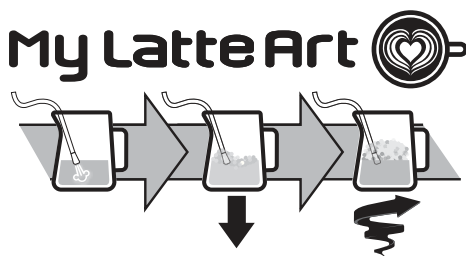

2. W celu spienienia mleka, umieścić rurkę wytwarzania pary (A6) na jego powierzchni: w ten sposób powietrze wymieszane się z mlekiem i parą.
3. Utrzymywać dyszę pary a powierzchni, pamiętając aby nie wychwytywać zbyt dużo powietrza, które wytworzy duże pęcherzyki.
4. Zanurzyć dyszę pary pod powierzchnią mleka: w ten sposób wytworzy się wir. Po osiągnięciu żądanej temperatury, zamknąć pokrętkę pary i przed wyjęciem dzbanka z mlekiem poczekać, aż wytwarzanie pary zostanie całkowicie przerwane.

Barman radzi:

- **Zimne mleko jest lepsze.** Zawsze używać zimnego mleka prosto z lodówki.
- Dla uzyskania lepszego rezultatu, należy zawsze włożyć dzbanek z mlekiem do lodówki.
- Tłuste mleko gwarantuje idealny rezultat. Rezultat i struktura pianki są zależne od rodzaju zastosowanego mleka krowiego lub napojów roślinnych.
- Po spienieniu mleka, usunąć pęcherzyki delikatnie przekreślając dzbanek na mleko.

Czyszczenie dyszy pary:

1. Po każdym użyciu, usunąć resztki mleka z dyszy pary (rys. 23) za pomocą szmatki. W celu dogłębnego wyczyszczenia, zaleca się zastosowanie Eco MultiClean: gwarantuje higienę, usuwając białka i tłuszcze z mleka i można go stosować do czyszczenia całego ekspresu.







2. W celu dokładnego wyczyszczenia dyszy (rys. 12) wytworzyć przez kilka sekund parę.
3. Poczekać na ostygnięcie dyszy: aby zagwarantować skuteczność dyszy, użyć igły czyszczenia (C11) w celu utrzymania wolnych 3 otworów (rys. 24).

6. SPERSONALIZOWAĆ ILOŚĆ NAPOJU NA BAZIE KAWY, UŻYWAJĄC PRZYCIŚKI (my) (B7)

1. Przygotować urządzenie do wytworzenia 1 lub 2 filiżanek napoju na bazie kawy, aż do zaczepienia uchwyty na filtr (C1) wraz z filtrem (C2) lub (C3) i kawą mieloną.
2. Przekręcić pokrętkę (B8) w celu wybrania napoju do zaprogramowania.
3. Wcisnąć przycisk (my): miga kontrolka odpowiadająca przyciskowi (my).
4. Wcisnąć przycisk OK, aby rozpocząć przygotowywanie. Kontrolki odpowiadające przyciskom OK i (my) będą migać.
5. Po osiągnięciu żądanej ilości, wcisnąć OK. Jeżeli napój przewiduje kolejny składnik, rozpoczyna się jego wytwarzanie: po osiągnięciu żądanej ilości, wcisnąć OK.
6. Wcisnąć przycisk (my), aby zapisać. Urządzenie jest gotowe do ponownego użycia i kontrolka (my) pozostaje włączona. Jeżeli nie chce się zapisać programowania, wcisnąć dowolny przycisk.

Zwróć uwagę:

- Można zaprogramować napoje z kawą, ale nie da się zaprogramować wytwarzania pary i gorącej wody.
- Programowanie zmienia ilości napojów, ale nie ilość zmielonej kawy.
- Napoje „X2” mogą być programowane oddzielnie.
- Aby przywrócić ustawienia fabryczne, przytrzymać wciśnięty przycisk (my), aż do momentu wyłączenia. Wybrany napój powróci do ustawień fabrycznych.

Kawa	Ilość ust. fabrycznie	Ilość możliwa do zaprogramowania
 Espresso	35 ml	od 25 do 90 ml
 Espresso X2	70 ml	od 50 do 180 ml
 Coffee	80 ml	od 50 do 120 ml
 Coffee X2	160 ml	od 120 do 240 ml
 Americano	120 ml	<ul style="list-style-type: none"> • espresso: od 25 do 60 ml • woda: od 25 do 120 ml
 Americano X2	240 ml	<ul style="list-style-type: none"> • espresso: od 50 do 120 ml • woda: od 50 do 240 ml







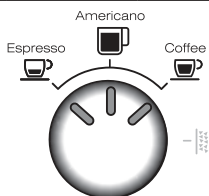

7. MENU USTAWIENÍ

1. Wejść do menu:



Równocześnie wcisnąć na 5 sekund	x2	
----------------------------------	----	--

2. Ustawienia z wyborem za pomocą pokrętki (B8)



Odpowiadające ustawienie	Ustawić na	Regulacje
Dodatkowa regulacja stopnia zmielenia	 Espresso	x2 → Zakres 1
		 → Zakres 2
Twardość wody	 Americano	x2 → miękka
		 → średnia
		 → twarda/bardzo twarda
Auto wyłączenie	 Coffee	x2 → 9 minut
		 → 1,5 godz.
		 → 3 godz.

3. Ustawienie z wyborem za pomocą przycisku:

Oszczędność energetyczna	 → Aktywny
	 → Wyłączony
Ustawienia fabryczne	Przytrzymać wciśnięty przycisk (my) przez przynajmniej 5 sekund, dopóki kontrolka nie będzie włączona

4. Zapisać nowe ustawienia wciskając ON/Standby (B1)

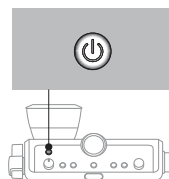











8. CZYSZCZENIE URZĄDZENIA

Uwaga!

- Do czyszczenia urządzenia nie używać rozpuszczalników, ściernych środków czyszczących lub alkoholu.
- Do usuwania kamienia osadowego lub osadów z kawy nie należy używać metalowych przedmiotów, mogłyby one zarysować metalowe lub plastikowe powierzchnie.
- W przypadku nieużytkowania przez okres dłuższy niż jeden tydzień zaleca się, przed ponownym użyciem ekspresu, przeprowadzenie płukania.

Niebezpieczeństwo!



- Podczas mycia nigdy nie zanurzać urządzenia w wodzie: jest to urządzenie elektryczne.
- Przed przystąpieniem do czyszczenia części zewnętrznych wyłączyć urządzenie, wyjąć wtyczkę z gniazdka prądu i poczekać, aż urządzenie wystygnie.

					
	×	✓	✓	×	×
	✓	×	×	✓	✓
	×	×	×	✓	✓
	×	×	×	✓	✓
	×	×	✓	✓	×
	×	×	×	✓	✓

8.1 Czyszczenie dozownika kawy

Gdy włączy się kontrolka  (pomarańczowa) (B13), konieczne jest wykonanie czyszczenia obwodu kawy. W celu przeprowadzenia cyklu czyszczenia, należy zakupić specjalne tabletki do czyszczenia ekspresu do kawy. Więcej informacji na www.Delonghi.com.



1. Włożyć filtr na 1 filiżankę (C2) do uchwytu na filtr (C1) (rys. 25).
2. Włożyć do filtra element czyszczący (C8) (rys. 25) i dochnąć do dna.

3. Umieścić tabletkę w elemencie (rys. 26).
4. Zamocować uchwyt na filtr w dozowniku kawy (A18).
5. Napełnić zbiornik wodą (A14). Upewnić się że tacka na skropliny (A10) jest pusta.
6. Przytrzymać przycisk  (B6), dopóki nie włączy się kontrolka  (B13). Po kilku minutach, czyszczenie kończy się automatycznie.
7. Wyjąć uchwyt na filtr i element czyszczący.
8. Umyć uchwyt na filtr i filtr pod bieżącą wodą.
9. Założyć uchwyt na filtr i przeprowadzić płukanie, wciskając przycisk  : pod uchwycem na filtr zaleca się ustawienie pojemnika.
10. Wyjąć i opróżnić tackę na skropliny.

Zwróć uwagę:

Taki cykl czyszczenia można uaktywnić w każdej chwili, wciskając przycisk  przez kilka sekund. Aby anulować czynność, wcisnąć przycisk przez 10 sekund.

8.2 Wyczyścić gniazdo pojemnika na ziarna

1. Upewnić się, że pojemnik na ziarna (A2) jest pusty. Ewentualnie wykonać kilka procesów mielenia bez ziaren, aby go opróżnić.
2. Odczepić pojemnik, przekręcając go w lewo i wyjąć z ekspresu (rys. 27)
3. Usunąć wszelkie resztki kawy (rys. 28).
4. Wyczyścić wilgotną szmatką gniazdo pojemnika na ziarna i wytrzeć na sucho (rys. 29);
5. Umieścić pojemnik wkładając w go do młynka kawy. Pojemnik jest włożony prawidłowo, gdy strzałka  będzie wyrównana z symbolem  i usłyszysz się „kliknięcie” (rys.30).

8.3 Czyszczenie żaren

Podczas czyszczenia pojemnika na ziarna (A2), wyczyścić jego gniazdo i górne żarno wilgotną szmatką. Zwrócić się do centrum serwisowego w celu usunięcia lub wymiany żaren.

Można wyjąć żarno, jeżeli młynek zostanie zablokowany przez obce ciało. Jeżeli tak się stanie, wyjąć pojemnik na ziarna i postępować następująco:

1. Zaczepić łyżkę uchwytu na filtr (C1) i wykonać jeden proces mielenia bez ziaren, w celu uwolnienia przewodu kawy.
2. Wyłączyć urządzenie.
3. Przekręcić regulator zmielenia w kierunku przeciwnym do kierunku ruchu wskazówek zegara, aż do ogranicznika, na pozycję „REMOVE” (rys. 31).
4. Wyjąć górną część żarna, chwytając za odpowiedni uchwyt (rys.32).
5. Wyczyścić żarno pędzelkiem (rys. 33) i usunąć resztki kawy za używając odkurzarka (rys. 28).

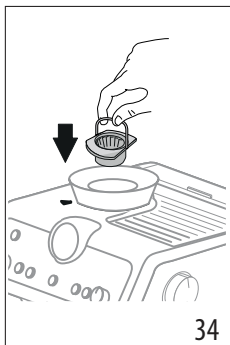
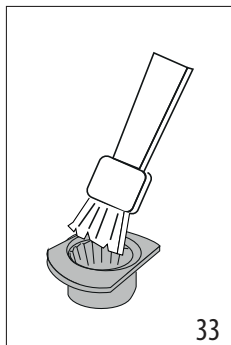

6. Włożyć żarno do gniazda (rys. 34);
7. Przekręcić regulator wybierając żądany stopień zmielenia (rys. 14);

Sprawdzić, czy żarno jest dobrze włożone, pociągając za uchwyt: żarno jest prawidłowo włożone, jeżeli jest nieruchome.

8.4 Wymiana żaren

Gdy ilość zmielonej kawy zmniejszy się, zwrócić się do centrum serwisowego w celu wymiany żaren: ponownie wyregulować młynek wchodząc do menu ustawień („7. Menu ustawień”) i wybierając pierwszy zakres regulacji extra zmielenia. Następnie przekręcić pokrętkę regulacji ilości (B2) na pozycję MIN i wyregulować dawkę, jak w przypadku pierwszego użycia (patrz „Idealna dawka”).

8.5 Czyszczenie „Smart tamping station”

1. Wyczyścić strefę zaczepienia za pomocą pędzelka (rys. 35).
2. Pociągnąć dźwignię (A20) do końca i wyczyścić praskę (rys. 36) pędzelkiem, następnie puścić dźwignię.
3. Za pomocą wycioru (C7) wyczyścić prowadnik kawy (rys. 37).

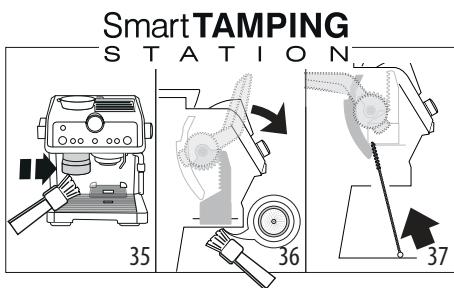

9. TWARDOŚĆ WODY

Kontrolka (B9) odkamieniania włącza się po ustalonym wcześniej okresie działania, który zależy od twardości wody. Można zaprogramować ekspres na podstawie twardości wody z

sieci wodociągowej różnych regionów, zmniejszając w ten sposób częstotliwość wykonywania odkamieniania.

1. Wyjąć z opakowania dołączony do urządzenia pasek kontrolny „TOTAL HARDNESS TEST” (C4).
2. Całkowicie zanurzyć pasek w szklance wody z kranu na około jedną sekundę.
3. Wyjąć pasek z wody i lekko nim potrząsnąć. Ustawić urządzenie, jak wskazano w rozdziale „7. Menu ustawień”.

Wynik Testu Twardości wody	Przycisk	Poziom
	×2	1 słodka woda
	≡ ⁸	2 woda średniej twardości
	OK	3 woda twarda lub bardzo twarda

4. Ustawić urządzenie, jak wskazano w rozdziale „7. Menu ustawień”.

10. JAK UŻYWAĆ SOFTBALLS

Softballs (C9) jest nowoczesnym system, który wydłuża żywotność urządzenia, nie wpływając na jakość wody i gwarantując parzenie kremowej i aromatycznej kawy. Aby zoptymalizować skuteczność działania, przed użyciem pozostawić Softballs na całą noc w wodzie.

1. Wyjąć pakiet Softballs z opakowania (rys. 38).

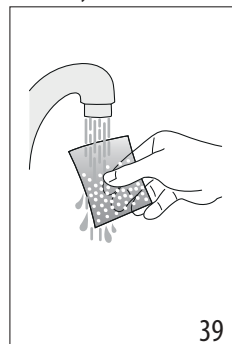
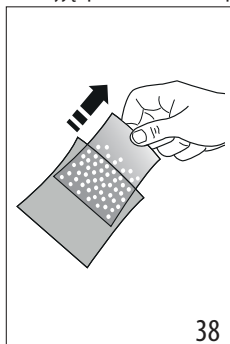

2. Wypłukać pakiet Softballs pod bieżącą wodą (rys. 39).
3. Zanurzyć woreczek w zbiorniku na wodę (A14) (rys. 40).

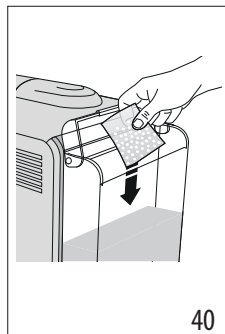

4. Wymieniać woreczek Softballs co 3 miesiące (rys. 41).

11. ODKAMNIENIE

Uwaga!

- Przed użyciem, przeczytaj instrukcję i etykietę odkamieniacza (C5), znajdującą się na jego opakowaniu.
- Zaleca się stosowanie wyłącznie odkamieniacza firmy De'Longhi. Użycie nieodpowiednich odkamieniaczy, jak również nieregularnie wykonywane odkamienianie może doprowadzić do usterek, których gwarancja producenta nie obejmuje.
- Odkamieniacz może uszkodzić delikatne powierzchnie. W razie przypadkowego rozlania, należy go natychmiast wycierać.

Aby przeprowadzić odkamienianie	
Odkamieniacz	Odkamieniacz De'Longhi
Pojemnik	Objętość 2 litry
Czas	~40min

1. (JEŻELI OBECNE, WYJĄĆ FILTR ZMIĘKZAJĄCY I SOFTBALLS). Włąć do zbiornika na wodę (A14) odkamieniacz, do poziomu **A** (opakowanie 100 ml), zaznaczonego wewnątrz zbiornika (rys. 42).

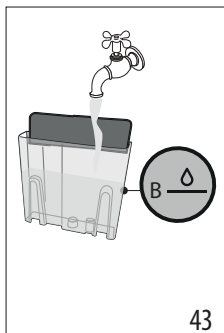
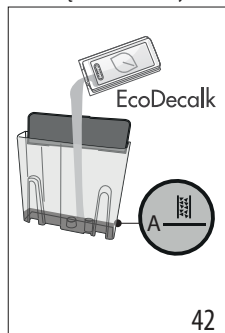

2. Dolać wodę do osiągnięcia poziomu **B** (rys. 43). Ponownie włożyć zbiornik na wodę do urządzenia.

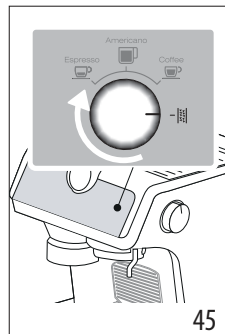
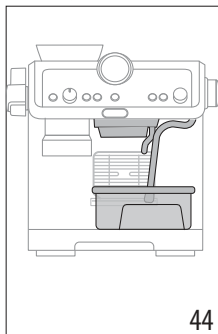

3. Upewnić się, że uchwyt na filtr (C1) nie jest zaczepiony i umieścić pojemnik pod dozownikiem kawy i dyszą gorącej wody oraz pod dyszą pary (A6) (rys. 44).
4. Ustawić pokrętko (B8) na **III** (rys. 45): kontrolka OK zapala się na pomarańczowo: miga kontrolka OK.
5. Wcisnąć przycisk OK: miga kontrolka OK.
6. Uruchomić się program odkamieniania i z dysz wypłynie woda. Program odkamieniający wykonuje automatycznie całą serię płukań, w celu usunięcia kamienia z ekspresu, aż do opróżnienia zbiornika.

Wytwarzanie zostanie przerwane, a kontrolka OK stanie się biała. W tym momencie należy przeprowadzić cykl płukania:

7. Opróżnić zbiornik użyty do zebrania płynu odkamieniającego i ponownie umieścić go pod dyszami.
8. Wyjąć zbiornik na wodę, opróżnić go z ewentualnych resztek roztworu odkamieniającego, wypłukać go i napełnić świeżą wodą do poziomu MAX (rys. 46). Ponownie włożyć zbiornik na miejsce.

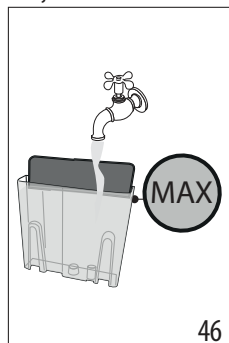









9. Wcisnąć przycisk OK: uaktywni się płukanie.
10. Po zakończeniu płukania, wytwarzanie zostanie przerwane i urządzenie będzie gotowe do użytku.
11. Opróżnić pojemniki użyte do zebrania wody z płukania.





12. Wyjąć i opróżnić tackę na skropliny, ponownie ją założyć na miejsce.
13. Wyjąć i napełnić świeżą wodą zbiornik; ponownie go włożyć na miejsce.
- Urządzenie jest gotowe do użycia.









Zwróć uwagę:



- W każdej chwili można uaktywnić cykl odkamieniania (nawet, jeżeli dana kontrolka nie jest jeszcze włączona).
- Jeżeli odkamienienie zostało uaktywnione przez przypadek, wcisnąć na 10 sekund przycisk OK; płukanie nie może być przerwane.

12. ZNACZENIE KONTROLEK



KONTROLKI	ZNACZENIE KONTROLEK	CZYNNOŚĆ
Wszystkie kontrolki migają krótko	Włączanie urządzenia	Autodiagnostyka
 stała	Nastąpiło pierwsze włączenie urządzenia i konieczne jest napełnienie obwodu wodą	Postępować jak wskazano w rozdz. "3. Pierwsze włączenie urządzenia"
 stała (biała)	Urządzenie jest gotowe do wytwarzania	Przygotować urządzenie i przystąpić do przygotowywania napoju
<ul style="list-style-type: none"> • Kontrolka  : wskazuje wybraną temperaturę kawy • Kontrolka  : wskazuje, że urządzenie jest gotowe do wytworzenia gorącej wody 		
 stała	Funkcja oszczędności energetycznej jest aktywna	Skonsultować rozdz. "7. Menu ustawień" jeżeli chce się wyłączyć funkcję
 stała	Pojemnik na ziarna (A2) jest pusty	Napełnić pojemnik ziarnami
 migająca	Chce się wykonać mielenie, ale pojemnik na ziarna (A2) jest pusty	Napełnić pojemnik ziarnami
 krótko miga w regularnych odstępach czasu	Pokrętko (B2) jest ustawione na pozycji maksymalnej regulacji	Jeżeli po mieleniu w filtrze znajduje się niewystarczająca ilość kawy, wybrać nowy zakres mielenia, jak wskazano w rozdziale "7. Menu ustawień".
 stała	Niewystarczająca ilość wody w zbiorniku (A14) lub zbiornik na wodę jest nieprawidłowo założony	Napełnić zbiornik lub wyjąć go i ponownie, prawidłowo włożyć
→		

KONTROLKI	ZNACZENIE KONTROLEK	CZYNNOŚĆ
 migająca	Chce się przygotować napój, ale zbiornik na wodę (A14) jest pusty	Napełnić zbiornik wodą
	Ziarna są zbyt drobno zmielone i dlatego kawa wypływa zbyt wolno i nie do końca	Wyjąć łyżkę uchwyty na filtr (C1), powtórzyć czynności w celu przygotowania kawy, uwzględniając wskazówki z par. „4.1 Etap 1 - Mielenie (grinding)” i „4.2 Etap 2 - Ubijanie (tamping)”
	Filtr kawy (C2) lub (C3) jest zatkany	Wypłukać filtry pod bieżącą wodą
	Zbiornik (A14) jest włożony nieprawidłowo i jego zawory są zamknięte	Lekko docisnąć zbiornik, aby otworzyły zawory
	Kamień wewnątrz obwodu hydraulicznego	Przeprowadzić odkamienianie, jak wskazano w rozdz. “11. Odkamienianie”
 stała	Urządzenie jest gotowe do wytworzenia pary	Urządzenie osiągnęło temperaturę do wytworzenia pary. Przystąpić do wytworzenia, przekręcić pokrętkę pary (A4)
 migająca	Urządzenie jest włączone i funkcja oszczędności energetycznej jest aktywna: pokrętkę pary (A4) na pozycji wytworzenia pary	Kontrolka miga wskazując, że urządzenie przygotowuje się do wytworzenia pary: wytworzenie zacznie się, jak tylko urządzenie osiągnie temperaturę
	Urządzenie jest gotowe do wytworzenia pary	Urządzenie osiągnęło temperaturę odpowiednią do wytworzenia pary, gdy kontrolka jest włączona na stałe
	Urządzenie wytwarza parę	
 stała	Nie jest włożony pojemnik na ziarna	Prawidłowo włożyć pojemnik na ziarna (A2) lub sprawdzić, czy jest prawidłowo włożony. Pojemnik jest włożony prawidłowo, gdy strzałka ▲ będzie wyrównana z symbolem ☞ i usłyszysz się „kliknięcie”
→		

KONTROLKI	ZNACZENIE KONTROLEK	CZYNNOŚĆ
 migająca	Regulacja przełącznika stopnia zmielenia jest nieprawidłowa lub powyżej maksymalnego dopuszczalnego poziomu	Ustawić przełącznik na jednej z pozycji mielenia (od 1 do 8), pamiętając, że należy: <ul style="list-style-type: none"> Wyregulować stopień mielenia podczas działania młynka Regulować po jednym poziomie na raz i wykonać przynajmniej 5 cykli mielenia pomiędzy jedną regulacją a kolejną
 stała	Urządzenie żąda ubijania Uchwyt na filtr został odcepiony z młynka kawy bez ubicia Uchwyt na filtr zostały odcepiony przed zakończeniem mielenia lub zbyt szybko ubito kawę Prowadnik kawy w młynku jest zatkany Żarna są zablokowane przez obce ciało	Zostało wykonane mielenie i uchwyt na filtr jest zaczepiony w młynku kawy Odczepić uchwyt na filtr i ubić kawę jak opisano w par. „Idealna dawka” „W przypadku stosowania kawy mielonej:” Powtórzyć mielenie Wyczyścić jak wskazano w par. „8.5 Czyszczenie „Smart tamping station”. Jeżeli problem trwa, przejść do prowadnika otwierając otwór i uwolnić go za pomocą wycioru Usunąć obce ciało i wyczyścić żarna jak wskazano w par. „8.3 Czyszczenie żaren”.
 stała (czerwona)	Należy przeprowadzić odkamienianie	Przeprowadzić odkamienianie, jak wskazano w rozdz. „11. Odkamienianie”
 miga (czerwona) +  miga (pomarańczowa)	Urządzenie przeprowadza odkamienianie	Postępować jak opisano w rozdz. „11. Odkamienianie”
 miga (czerwona) +  stała (biała)	Konieczne przeprowadzenie płukania	
 miga (czerwona) +  miga (biała)	Urządzenie przeprowadza płukanie cyklu odkamieniania	
→		

KONTROLKI	ZNACZENIE KONTROLEK	CZYNNOŚĆ
 Stała (pomarańczowa)	Należy przeprowadzić czyszczenie dozownika kawy	Patrz par. "8.1 Czyszczenie dozownika kawy"
 migająca (pomarańczowa)	Urządzenie przeprowadza czyszczenie dozownika kawy	
Migają wszystkie kontrolki	Alarm ogólny	Zwrócić się do centrum serwisowego

13. NIEPRAWIDŁOŚCI

PROBLEM	PRZYCZYNA	ROZWIĄZANIE
W tacce na skropliny (A10) znajduje się woda	Jest to normalne działanie wewnętrznych obwodów urządzenia	Regularnie opróżniać i czyścić tackę na skropliny
Kawa espresso nie wypływa	Brak wody w zbiorniku (A14)	Napełnić zbiornik
	Kontrolka  (B6) jest włączona wskazując, że obwód kawy lub obwód pary jest pusty	Wcisnąć przycisk odpowiadający kontrolce  w celu napełnienia obwodu
	Filtr (C2) lub (C3) jest zatkany	Wypłukać filtry pod bieżącą wodą
	Zbiornik (A14) jest źle umieszczony i zawory znajdujące się na dnie są zamknięte	Delikatnie docisnąć zbiornik, aby otworzyć znajdujące się na dnie zawory
	Kamień wewnątrz obwodu hydraulicznego	Przeprowadzić odkamienianie, jak wskazano w rozdz. "11. Odkamienianie"
	Ziarna są zbyt drobno zmielone	Wyjąć łyżkę uchwytu na filtr (C1), powtórzyć czynności w celu przygotowania kawy, uwzględniając wskazówki z par. "4.1 Etap 1 - Mielenie (grinding)" i "4.2 Etap 2 - Ubijanie (tamping)"
Nie można zaczepić uchwytu na filtr na urządzeniu	Kawa mielona nie została ubita lub jest jej za dużo	Powtórzyć mielenie z innymi ustawieniami. Zmniejszyć ilość dawki: sprawdzić, czy filtr (C2) lub (C3) (1 lub 2 filizanki) jest prawidłowo do mielonej dawki (przycisk 2x (B3) wybrany czy nie)
Kawa espresso kapie z brzegów uchwytu na filtr (C1) zamiast z otworów	Uchwyt na filtr jest źle założony	Prawidłowo założyć uchwyt na filtr i przekręcić do oporu
	Uszczelka dozownika kawy (A18) straciła elastyczność lub jest brudna	Wymienić uszczelkę dozownika kawy w Autoryzowanym Centrum Serwisowym
	Filtr (C2) lub (C3) jest zatkany	Wypłukać filtry pod bieżącą wodą
Pianka na kawie jest jasna (kawa wypływa z otworu szybko)	Należy sprawdzić ustawienia urządzenia	Wyjąć łyżkę, powtórzyć czynności do przygotowania kawy, uwzględniając wskazówki z par. "4.1 Etap 1 - Mielenie (grinding)" i "4.2 Etap 2 - Ubijanie (tamping)"
		→

PROBLEM	PRZYCZYNA	ROZWIĄZANIE
Pianka na kawie jest ciemna (kawa wypływa z otworu powoli)	Należy sprawdzić ustawienia urządzenia	Wyjąć łyżkę uchwytu na filtr (C1), powtórzyć czynności w celu przygotowania kawy, uwzględniając wskazówki z par. „4.1 Etap 1 - Mielenie (grinding)” i „4.2 Etap 2 - Ubijanie (tamping)”
Po zakończeniu odkamieniania, urządzenie wymaga kolejnego płukania	Podczas cyklu płukania, zbiornik nie został napełniony do poziomu MAX	Powtórzyć płukanie (patrz rozdz. “11. Odkamienianie”)
Urządzenie nie mieli kawy	Wewnątrz młynka do kawy znajduje się obce ciało	Wycisnąć żarna jak wskazano w par. „8.3 Czyszczenie żaren”, upewniając się o usunięciu wszystkich ziaren z pojemnika na ziarna (A2) przed jego wyjęciem. Przed ponownym włożeniem żarna, usunąć wszelkie resztki z jego gniazda
	Pojemnik na ziarna (A2) nie znajduje się na prawidłowej pozycji	Pojemnik jest włożony prawidłowo, gdy strzałka ▲ będzie wyrównana z symbolem ☒ i usłyszysz się „kliknięcie”
Jeżeli chce się zmienić ilość kawy	Należy usunąć wszystkie ziarna z urządzenia	<ul style="list-style-type: none"> • Opróżnić pojemnik na ziarna (A2) (wykonując mielenie bez kawy lub usuwając pozostające ziarna) • Zaczepić łyżkę uchwytu na filtr (C1) i włączyć mielenie bez kawy, aby opróżnić przewód kawy: następnie zaczepić uchwyt na filtr na wylocie młynka (A19) wyrównując go z napisem INSERT i przekręcić łyżkę w prawo. Mielenie rozpocznie się, gdy łyżka znajdzie się na pozycji CLOSE i zostanie przerwane automatycznie. Powtarzać, dopóki filtr nie będzie pusty • Wsypać do pojemnika (A2) nowy rodzaj ziaren kawy • Jeżeli po zmieleniu nie osiągnie się „idealnej dawki”, postępować jak w przypadku pierwszego użycia
		→

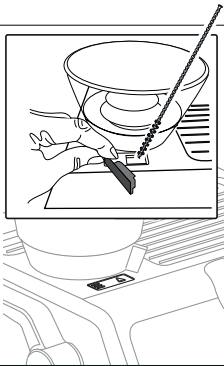
PROBLEM	PRZYCZYNA	ROZWIĄZANIE
<p>Po zmieleniu, filtr kawy (C2) lub (C3) jest pusty</p> <p>Po zmieleniu, w filtrze jest zbyt dużo kawy</p>	<p>Prowadnik kawy w młynku jest zatkany</p>	<p>Wyczyścić jak wskazano w par. „8.5 Czyszczenie „Smart tamping station””. Jeżeli problem trwa, przejść do prowadnika otwierając otwór (A21) i uwolnić go za pomocą wycioru</p> 
<p>Po zmieleniu, kawa w filtrze (C2) lub (C3) nie osiąga „idealnej dawki”</p>	<p>„Smart Tamping Station” wymaga wyczyszczenia</p> <p>Należy wyregulować ilość zmielonej kawy</p> <p>Z czasem żarna ulegają zużyciu</p>	<p>Wyczyścić jak wskazano w par. „8.5 Czyszczenie „Smart tamping station””, następnie powtórzyć mielenie</p> <p>Wyregulować ilość za pomocą odpowiedniego pokrętki (B2), stosując się do wskazówek z par. „„Idealna dawka””. Jeżeli pokrętło znajduje się już na pozycji maks., postępować jak wskazano w sekcji „7. Menu ustawień” - „Dodatkowa regulacja stopnia zmielenia”</p> <p>Wymienić żarna je jak wskazano w par. „8.4 Wymiana żaren”</p>

Înainte de a utiliza aparatul, citiți întotdeauna broșura cu instrucțiunile de siguranță.

1. DESCRIERE

1.1 Descrierea aparatului - A

- A1. Capac recipient boabe
- A2. Recipient pentru boabe
- A3. Suport pentru cești
- A4. Buton abur
- A5. Distribuitor apă caldă
- A6. Duză de distribuire a aburului
- A7. Grătar suport cești pentru espresso
- A8. Grătar suport cești pentru pahare sau căni
- A9. Grătar tăvișă
- A10. Tăvișă de colectare a picăturilor
- A11. Indicator nivel apă din tăvișă de colectare a picăturilor
- A12. Capac rezervor apă
- A13. Mâner scoatere rezervor de apă
- A14. Rezervor de apă
- A15. Locaș filtru de dedurizare a apei
- A16. Locaș conector cablu de alimentare
- A17. Întrerupător general (ON/OFF)
- A18. Distribuitor cafea
- A19. Ieșire rășniță de cafea (Tamping station)
- A20. Manetă de presare
- A21. Ușiță pentru accesul la ștuțul rășniței de cafea

1.2 Descrierea panoului de control - B

- B1. Tastă ON/Standby
- B2. Buton pentru reglarea cantității de cafea măcinată
- B3. Tasta „X2”: pentru a utiliza filtrul cu 2 cafele
- B4. Tastă „temperatură cafea”
- B5. Tastă „OK”: pentru a prepara băutura/pentru a confirma
- B6. Tastă „distribuție apă caldă”
- B7. Tasta „My”: pentru personalizarea lungimii băuturilor
- B8. Buton pentru selectare funcții
 - Espresso
 - Americano
 - Cafea
 - Decalcifiere
- B9. Indicator luminos de „decalcifiere”
- B10. Indicator luminos „abur pregătit”
- B11. Indicator „lipsă rezervor boabe”
- B12. Indicator luminos de „economisire a energiei”
- B13. Indicator luminos „Curățare” (a se vedea „8.1 Curățarea dozatorului de cafea”)
- B14. Indicator „rezervor boabe gol”
- B15. Indicator luminos „lipsă apă”
- B16. Indicator luminos „presare”
- B17. Manometru

1.3 Descrierea accesoriilor - C

- C1. Manetă cupă suport de filtru
- C2. Filtru 1 ceașcă
- C3. Filtru 2 cești
- C4. Bandă reactivă pentru testarea durezzații apei „Total Hardness Test”
- C5. Decalcifiant
- C6. Cablu de alimentare detașabil
- C7. Perie
- C8. Accesoriu pentru curățarea dozatorului de cafea
- C9. Softballs
- C10. Ibriș lapte
- C11. Ac de curățare pentru tubul de aburi

1.4 Accesorii de curățare neincluse, recomandate de producător

Pentru mai multe informații, vizitați Delonghi.com.

Pastile pentru curățare

(A se vedea „8.1 Curățarea dozatorului de cafea”)



EcoMultiClean Detergent
EAN: 800439933307

2. PREGĂTIREA APARATULUI

Spălați toate accesoriile cu apă caldă și detergent pentru vase, apoi procedați după cum urmează:

1. Introduceți recipientul pentru boabe (A2) în rășnița de cafea (fig. 1). Recipientul este introdus corect când săgeata ▲ este aliniată cu simbolul ☐ și se aude un „clic” (fig. 2).
2. Introduceți tava de colectare picături (A10) împreună cu grătarul pentru cești (A8) și grătarul pentru tavă (A9) (fig. 3);
3. Scoateți rezervorul pentru apă (A14) (fig. 4) și umpleți-l cu apă proaspătă și curată, având grijă să nu depășiți semnul MAX (fig. 5).
4. Apoi introduceți la loc rezervorul.

Atenție: Nu puneți niciodată în funcțiune aparatul, fără apă în rezervor sau fără rezervor.

Rețineți: Vă recomandăm să personalizați cât mai curând durezzații apei, urmând procedura descrisă în capitolul „7. Meniu setări”.

3. PRIMA PUNERE ÎN FUNCȚIUNE A APARATULUI

1. Introduceți conectorul cablului de alimentare (C6) în locașul special prevăzut (A16) pe spatele aparatului (fig. 6); apoi introduceți ștecărul în priză. Asigurați-vă că întrerupătorul general, (A17) care se află în partea posterioară a aparatului, a fost apăsat în poziția I (fig. 7);
2. Așezați sub dozatorul de apă fierbinte (în corespondență cu dozatorul de cafea (A18)) un recipient cu o capacitate minimă de 100 ml (fig. 8);

3. Apăsăți tasta (B6) din dreptul indicatorului luminos (☺) (fig. 9): curgerea începe și apoi se întrerupe automat. Goliți recipientul.

Înainte de a începe să utilizați aparatul, este necesar să clătiți circuitele interne ale aparatului. Procedați în felul următor:

4. Cuplați cupa de suport a filtrului (C1) cu tot cu filtru, pe aparat: pentru o cuplare corectă, aliniați mânerul cupei de suport a filtrului cu simbolul „INSERT” (fig. 10) și rotiți mânerul spre dreapta, până când acesta va fi aliniat cu poziția „CLOSE”;
5. Puneți un recipient sub cupa suportului filtrului și a duzei de distribuire a aburului (A6);
6. Apăsăți tasta OK (B5) (fig. 11): începe distribuirea;
7. După distribuire, rotiți butonul pentru abur (A4) (fig. 12) și distribuiți aburul câteva secunde pentru a clăti circuitul de abur: pentru o livrare optimă a aburului, se recomandă repetarea acestei operațiuni de 3 sau 4 ori. Acest lucru permite eliminarea apei din duză înainte de distribuirea aburului.

Apoi, aparatul este gata de utilizare.

Rețineți: clătirea circuitelor interne se recomandă și în cazul neutilizării îndelungate a aparatului.

La prima utilizare, va trebui să preparați 4-5 cafele, până când aparatul va începe să dea cele mai bune rezultate: accordați o atenție deosebită dozei de cafea măcinată din filtru ((C2) sau (C3)) (consultați instrucțiunile din paragraful „4.1 Faza 1 - Măcinare (grinding)”).

Procedați conform indicațiilor din capitolul „Doza perfectă”.

4. PREPARAREA CAFELEI

4.1 Faza 1 - Măcinare (grinding)

1. Vărsați boabele în recipient (A2) (fig. 13). Se recomandă să adăugați numai boabele necesare pentru preparare: în acest fel veți folosi întotdeauna cafea proaspătă;
2. Selectați gradul de măcinare (fig. 14). Setarea din fabrică este 5 (măcinare medie). Dacă rezultatul nu este satisfăcător, reglați nivelul în funcție de gustul personal și de tipul de cafea (reglarea trebuie făcută în timp ce rășnița de cafea funcționează).

Rețineți: Gradul de măcinare între 3 și 6 este recomandat pentru majoritatea tipurilor de cafea. Rezultatul măcinării cu selecție pe 1 sau 2 este foarte fin; se recomandă a fi utilizat numai cu cafea foarte specială (prăjită ușor).

3. Introduceți unul dintre filtrele de cafea (C2) sau (C3) în suportul filtrului (C1) (fig. 15). Dacă utilizați filtrul pentru 2 cești, apăsați tasta X2 (B3): cu această selecție, se dublează, de asemenea, cantitatea de espresso livrată.
4. Reglați butonul pentru cantitate (B2) plecând de la poziția minimă (fig. 16).

Consultați paragraful „Reglați cantitatea de cafea măcinată în filtru” pentru informații suplimentare.

5. Agățați suportul filtrului la orificiul de ieșire al rășniței de cafea (A19) aliniindu-l cu mesajul INSERT: apoi răsuciți cupa către dreapta. Măcinarea începe când cupa ajunge în poziția CLOSE și se întrerupe automat.

Reglați cantitatea de cafea măcinată în filtru

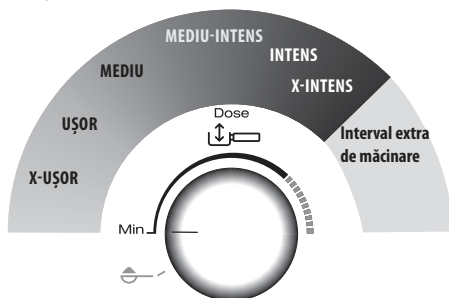

Fiecare varietate de boabe dă un rezultat diferit în timpul măcinării și, din acest motiv, la început, ajustarea dozei necesită foarte multă atenție.

Această ilustrație oferă indicații despre modul de ajustare a dozei, pe baza culorii de prăjire: acestea trebuie considerate un punct de plecare, dar pot varia în funcție de compoziția boabelor de cafea.

1. Setăți doza din poziția minimă.
2. Făcând referire la culoarea boabelor prăjite, rotiți încet butonul.

4.2 Faza 2 - Presare (tamping)

1. După măcinare, coborâți maneta de presare (A20) până la capăt (nu scoateți suportul filtrului) (fig. 17). Pentru un rezultat perfect, repetați de 2 ori.
2. Țineți maneta coborâtă până la sfârșit în timpul îndepărtării suportului filtrului (fig. 18). Apoi readuceți maneta în poziția sa inițială.
3. După ce ați verificat dacă doza de cafea este corectă (a se vedea „Doza perfectă”), atașați suportul filtrului la doza-torul de cafea (A18) (fig. 19).

Rețineți: Dacă după presare rămâne cafea de-a lungul marginilor filtrului, acest lucru nu afectează calitatea extracției și, prin urmare, rezultatul final.

„Doza perfectă”

- Filtrele de cafea au o referință internă pentru a identifica doza perfectă.



- Filtre cu marcaj laser: doza perfectă corespunde liniei superioare a marcajului;









- Filtre cu marcaj în relief: doza perfectă corespunde liniei în relief;
- Asigurați-vă că după apăsare, cafeaua se încadrează în nivel. Poate fi necesar să reglați butonul (B2) de mai multe ori înainte de a ajunge la doza perfectă.
- În cazul în care cafeaua este supra sau sub-extrasă și doza se încadrează în doza perfectă, reglați gradul de măcinare mai fin sau mai grosier (a se vedea „4.1 Faza 1 - Măcinare (grinding)”). În cazul în care cafeaua este supra-extrasă (livrarea este prea lentă), măcinarea trebuie să fie mai grosieră. În cazul în care cafeaua este sub-extrasă (livrarea este prea rapidă), măcinarea va trebui să fie mai fină.
- **Barmanul recomandă:** Să îndepărtați suportul filtrului în timp ce maneta de presare (A20) este coborâtă pentru a obține o finisare perfectă a dozei de cafea.
- **Dacă se utilizează cafea pre-măcinată:**
 - se toarnă cafeaua pre-măcinată în filtru;
 - rotiți butonul către ;
 - Agățați suportul filtrului la orificiul de ieșire al râșniței de cafea;
 - coborâți maneta de presare.

4.3 Faza 3 - Distribuire (brewing)

1. Selectați temperatura (fig. 20) (a se vedea „Temperatura pentru prepararea cafelei”).
2. Selectați băutura dorită (fig. 21).
3. Apăsăți OK (B5) pentru a începe distribuirea (fig. 11) (pre-infuzie și infuzie). Distribuirea cafelei se oprește automat.

Temperatura pentru prepararea cafelei

Temperatura apei este controlată pe parcursul întregului proces de preparare pentru a asigura stabilitatea acesteia în timpul fazei de extracție. Specialistul Prestigio oferă 3 temperaturi de infuzie* care corespund unui interval cuprins între 92 °C și 96 °C. În funcție de varietatea și de gradul de prăjire a boabelor de cafea, se recomandă o temperatură diferită: boabele de cafea Robusta necesită o temperatură joasă; boabele de cafea Arabica, o temperatură ridicată. Același lucru este valabil și pentru boabele prăjite de culoare închisă, sau pentru boabele care tocmai au fost prăjite.

Nivel de temperatură	Indicator luminos corespunzător	Nivel de prăjire
MIN	   	Întunecat
MED	   	Mediu-întunecat

MAX	   	Ușor-intens
------------	--	--------------------

- * Această temperatură se referă la apa din termobloc. Prin urmare, este diferită de temperatura băuturii din ceașcă sau de temperatura măsurată atunci când băutura iese din dozatoarele suportului filtrului.

5. PREGĂTIREA BĂUTURILOR DIN LAPTE

5.1 Spumați laptele

1. Se toarnă cantitatea de lapte care trebuie încălzită/spumată în ibric (C10), ținând cont că volumul de lapte va crește de 2 sau 3 ori (fig. 22). Pentru a obține o spumă mai densă și omogenă, se recomandă utilizarea laptelui integral de vacă la temperatura frigiderului (aproximativ 5 °C).

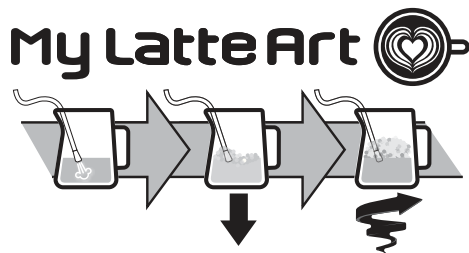

2. Pentru a spuma laptele, așezați duza de distribuire a aburului (A6) pe suprafața laptelui: procedând astfel, aerul se amestecă cu laptele și aburul.
3. Păstrați distribuitorul de abur pe suprafață, având grijă să nu captați prea mult aer, creând bule prea mari.
4. Scufundați distribuitorul de abur sub suprafața laptelui: în acest mod se creează un vârtej. Odată ce temperatura dorită este atinsă, închideți butonul pentru abur și așteptați ca distribuirea aburului să se oprească complet înainte de a scoate ibricul de lapte.

Barmanul recomandă:

- **Laptele proaspăt este cel mai bun.** Utilizați întotdeauna lapte proaspăt la temperatura frigiderului.
- Pentru cele mai bune rezultate, se recomandă să puneți întotdeauna ibricul cu lapte în frigider.
- Laptele integral asigură rezultate excelente. Rezultatul și textura spumei variază în funcție de laptele de vacă sau băuturile vegetale utilizate.
- După spumarea laptelui, îndepărtați bulele rotind ușor ibricul cu lapte.

Curățarea dozatorului de abur:

1. După fiecare utilizare, îndepărtați cu o cârpă orice reziduu de lapte din dozatorul de abur (fig. 23). Pentru o curățare în profunzime se recomandă să utilizați Eco MultiClean: asi-

gură igiena prin îndepărtarea proteinelor și a grăsimilor din lapte și poate fi utilizat pentru curățarea întregului aparat.

2. Distribuieți abur câteva secunde pentru a curăța bine dozatorul (fig. 12).
3. Așteptați ca dozatorul să se răcească: pentru a menține eficiența dozatorului în timp, utilizați acul de curățare (C11) pentru a menține cele 3 găuri libere (fig. 24).







6. PERSONALIZAREA LUNGIMII BĂUTURILOR PE BAZĂ DE CAFEA CU AJUTORUL TASTEI (my) (B7)

1. Pregătiți aparatul pentru a prepara 1 sau 2 cești cu băutura pe bază de cafea pe care o doriți, până la cuplarea suportului de filtru (C1) cu tot cu filtrul (C2) sau (C3) și cu cafeaua măcinată.
2. Rotiți butonul (B8) pentru a selecta băutura care urmează să fie programată.
3. Apăsăți tasta (my): indicatorul luminos corespunzător tastei (my) clipește.
4. Apăsăți tasta OK pentru a începe distribuirea. Luminile corespunzătoare tastelor OK și (my) clipeșc.
5. Odată ce ați atins cantitatea dorită, apăsați OK. Dacă băutura necesită distribuirea unui alt ingredient, începe distribuirea acestuia din urmă: odată atinsă cantitatea dorită, apăsați OK.
6. Apăsăți tasta (my) pentru a salva. Aparatul este gata pentru o nouă utilizare, iar indicatorul luminos (my) rămâne aprins.

Dacă nu doriți să salvați programarea, apăsați orice altă tastă.

Rețineți:

- Puteți programa băuturile pe bază de cafea, dar nu cu distribuire de abur și apă fierbinte.
- Programarea modifică toate cantitățile de băuturi, dar nu și de cafea măcinată.
- Băuturile „X2” pot fi programate separat.
- Pentru a reveni la setările din fabrică, țineți apăsată tasta (my) până la oprire. Băutura selectată revine la cantitatea din fabrică.

Rețetă de cafea	Cantitate din fabrică	Cantitate programabilă
 Espresso	35 ml	de la 25 la 90 ml
 Espresso X2	70 ml	de la 50 la 180 ml
 Coffee	80 ml	de la 50 la 120 ml
 Coffee X2	160 ml	de la 120 la 240 ml
 Americano	120 ml	<ul style="list-style-type: none"> • espresso: de la 25 la 60 ml • apă: de la 25 la 120 ml
 Americano X2	240 ml	<ul style="list-style-type: none"> • espresso: de la 50 la 120 ml • apă: de la 50 la 240 ml







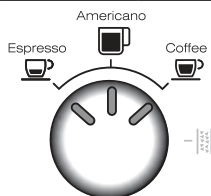

7. MENU SETĂRI

1. Intrați în meniu:



Apăsăți simultan timp de 5 secunde	x2	
------------------------------------	----	--

2. Setări cu selecție din mâner (B8)



Setare corespunzătoare	Rotiți spre	Ajustări
Reglare suplimentară a măcinării		x2 → Interval 1
		 → Interval 2
Duritate apă		x2 → dulce
		 → medie
		 → dură/foarte dură
Oprire automată		x2 → 9 minute
		 → 1,5 ore
		 → 3 ore

3. Setare cu selectare din tastă:

Consum redus de energie	 → Activ
	 → Oprit
Valori din fabrică	Țineți apăsată tasta (my) timp de cel puțin 5 secunde, până când indicatorul luminos rămâne aprins constant

4. Salvați noile setări apăsând ON/Standby (B1)

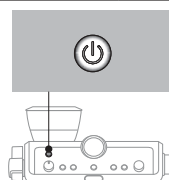











8. CURĂȚAREA APARATULUI

Atenție!

- Pentru curățarea aparatului nu folosiți solvenți, detergenți abrazivi sau alcool.
- Nu utilizați obiecte metalice pentru a îndepărta depunerile de calcar sau de cafea, deoarece ar putea zgâria suprafețele din metal sau din plastic.
- Pentru perioade de neutilizare mai lungi de o săptămână, se recomandă clătirea acestuia înainte de a utiliza aparatul.

Pericol!



- În timpul operațiunilor de curățare, nu introduceți niciodată aparatul în apă: este un aparat electric.
- Înainte de orice operațiune de curățare a părților externe ale aparatului, opriți mașina, scoateți ștecărul din priză de curent și lăsați mașina să se răcească.

					
	✗	✓	✓	✗	✗
	✓	✗	✗	✓	✓
	✗	✗	✗	✓	✓
	✗	✗	✗	✓	✓
	✗	✗	✓	✓	✗
	✗	✗	✗	✓	✓

8.1 Curățarea dozatorului de cafea

Când lumina  se aprinde (portocalie) (B13), este necesar să curățați circuitul de cafea. Pentru a rula ciclul de curățare, cum-părați pastile pentru curățarea aparatelor de cafea. Pentru mai multe informații, vizitați www.Delonghi.com.

1. Introduceți filtrul de 1 ceașcă (C2) în suportul filtrului (C1) (fig. 25).
2. Introduceți accesoriul de curățare (C8) în filtru (fig. 25) și apăsați-l complet.
3. Puneți pastila de curățat pe accesoriu (fig. 26).
4. Atașați suportul filtrului la dozatorul de cafea (A18).

5. Umpleți rezervorul de apă (A14). Asigurați-vă că tava de scurgere (A10) este goală.
6. Mențineți apăsată tasta  (B6), până când se aprinde indicatorul luminos  (B13). După câteva minute, curățarea se oprește automat.
7. Scoateți suportul filtrului și accesoriul de curățare.
8. Spălați suportul filtrului și filtrul cu apă de la robinet.
9. Reintroduceți suportul filtrului și continuați cu clătirea apă-sând tasta  : se recomandă să amplasați un recipient sub suportul filtrului.
10. Scoateți și goliți tava de scurgere.

Rețineți:

Acest ciclu de curățare poate fi pornit în orice moment prin apăsarea tastei  timp de câteva secunde. Pentru a anula operațiunea, apăsați butonul timp de 10 secunde.

8.2 Curățați carcasa recipientului pentru boabe

1. Asigurați-vă că recipientul pentru boabe (A2) este gol. Dacă este necesar, continuați cu unele măcinări în gol pentru a-l goli.
2. Desprindeți recipientul rotindu-l în sens invers acelor de ceasornic și scoateți-l din aparat (fig. 27)
3. Aspirați resturile de cafea (fig. 28).
4. Curățați locașul recipientului pentru boabe cu o cârpă umedă și uscați (fig. 29);
5. Repoziționați recipientul introducându-l în râșnița de cafea. Recipientul este introdus corect când săgeata ▲ este aliniată cu simbolul  și se aude un „clic” (fig.30).

8.3 Curățarea râșnițelor

Când curățați recipientul pentru boabe (A2), curățați locașul recipientului și lama de măcinare superioară cu o cârpă umedă. Contactați un centru de service pentru a îndepărta și înlocui râșnițele. Lama de măcinare poate fi îndepărtată dacă râșnița de cafea este blocată de un corp străin. Dacă se întâmplă acest lucru, scoateți recipientul pentru boabe și procedați după cum urmează:

1. Atașați cupa suportului de filtru (C1) și măcinați „în gol” pentru a elibera conducta de cafea.
2. Închideți aparatul.
3. Rotiți butonul de reglare măcinare în sens invers acelor de ceasornic până la capăt, în poziția „REMOVE” (fig. 31).
4. Îndepărtați partea superioară a lamei de măcinare, apucând-o de mânerul corespunzător (fig. 32).
5. Curățați lama de măcinare cu o pensulă (fig. 33) și aspirați resturile de cafea, cu un aspirator (fig. 28).

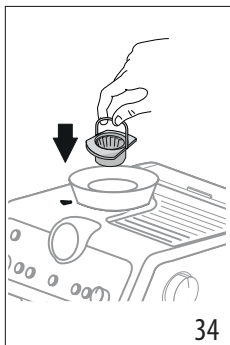
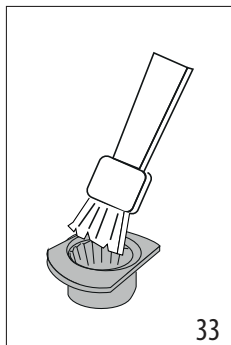

- introduceți lama de măcinare în locașul său (fig. 34);
- roțiți regulatorul selectând gradul de măcinare dorit (fig. 14);

Verificați ca lama de măcinare să fie bine introdusă, trăgând-o de mâner: aceasta este introdusă corect dacă nu se mișcă.

8.4 Înlocuirea lamelor de măcinare

Când cantitatea de cafea măcinată continuă să se reducă, contactați un centru de service pentru a înlocui lamele de măcinare: apoi reglați din nou rășnița de cafea intrând în meniul de setări („7. Meniu setări”) și selectând primul interval de reglare suplimentar al măcinării. Apoi, roțiți butonul de reglare a cantității (B2) în poziția MIN și reglați doza ca la prima utilizare (vezi „Doza perfectă”).

8.5 Curățarea „Smart tamping station”

- Curățarea zonei de fixare cu o pensulă (fig. 35).
- Trageți maneta (A20) până la capăt și curățați maneta de presare cu o perie (fig. 36), apoi eliberați maneta.
- Cu ajutorul periei (C7) curățați ștuțul de cafea (fig. 37).

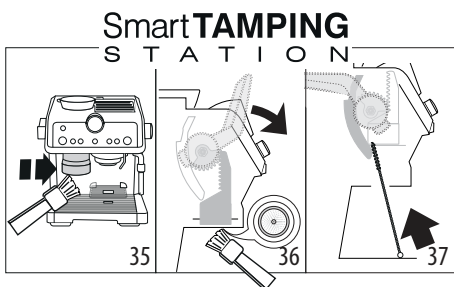

- Scoateți din ambalaj banda reactivă furnizată „TOTAL HARDNESS TEST” (C4).
- Introduceți complet banda într-un pahar cu apă, timp de aproximativ o secundă.
- Scoateți banda din apă și scuturați-o ușor. Configurați aparatul, astfel cum este indicat în capitolul „7. Meniu setări”.

Rezultatul testului de duritate a apei	Tastă	Nivel
	× 2	1 apă dulce
	≡ ⚙	2 apă medie
	⊙ OK	3 apă dură sau foarte dură

- Configurați aparatul, astfel cum este indicat în capitolul „7. Meniu setări”.

10. CUM SĂ UTILIZAȚI SOFTBALLS

Softballs (C9) este un sistem inovator care prelungeste durata de viață a mașinii, fără modificarea calității apei, asigurând distribuția unei cafele cremoase și aromate. Pentru a optimiza eficiența, lăsați Softballs în apă toată noaptea înainte de utilizare.

- Scoateți pachetul de Softballs din ambalaj (fig. 38).

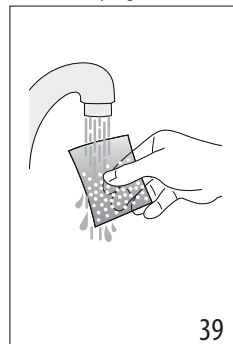
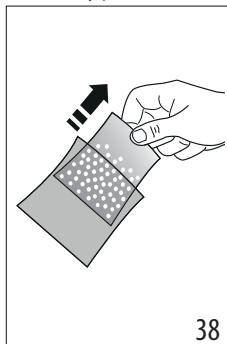

- Clătiți cu apă de la robinet pachetul de Softballs (fig. 39).
- Introduceți punga în rezervorul de apă (A14) (fig. 40).

9. DURITATE APĂ

Indicatorul luminos (B9) de decalcifiere se aprinde după o anumită perioadă de funcționare prestabilită, care depinde de duritatea apei. Este posibilă programarea aparatului în funcție de duritatea reală a apei folosită în diferite regiuni, efectuând astfel, mai rar, operațiunea de decalcifiere.

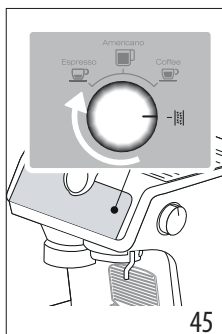
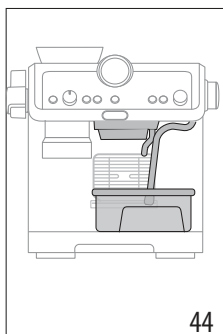
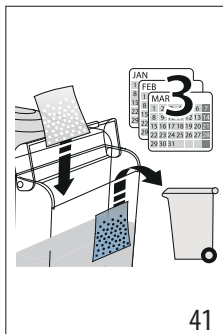
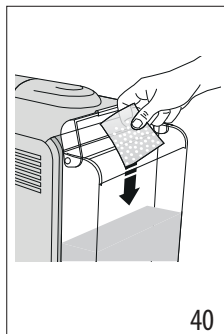

4. Înlocuiți punga de Softballs la fiecare 3 luni (fig. 41).

11. DECALCFIERE

Atenție!

- Înainte de utilizare, citiți instrucțiunile și eticheta produsului de decalcifiere (C5), aflate pe ambalajul acestuia.
- Se recomandă să utilizați numai decalcifiant De'Longhi. Utilizarea unor decalcifianți necorespunzători, precum și o decalcifiere care nu este efectuată cu regularitate, pot duce la apariția unor defecțiuni ce nu sunt acoperite de garanția producătorului.
- Decalcifiantul poate deteriora suprafețele delicate. În caz de vărsare accidentală a produsului, ștergeți-l imediat.

Pentru a efectua ciclul de decalcifiere	
Decalcifiant	Decalcifiant De'Longhi
Recipient	Capacitate 2 litri
Timp	~40min

1. (DACĂ ESTE PREZENT, ÎNDEPĂRTAȚI FILTRUL DE DEDURIZARE ȘI SOFTBALLS). Vărsați în rezervorul de apă (A14) decalcifiantul până la nivelul A (corespunzător unui pachet de 100 ml) marcat în interiorul rezervorului (fig. 42).

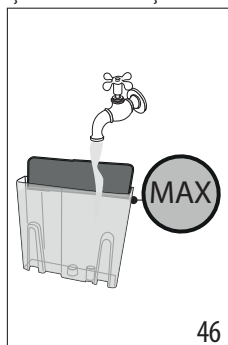
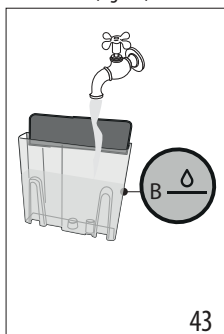
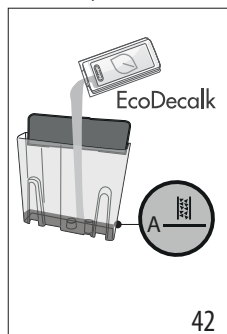

2. Adăugați apă până ajungeți la nivelul B (fig. 43). Apoi puneți rezervorul de apă înapoi în mașină.

3. Asigurați-vă că suportul filtrului (C1) nu este agățat și așezați un recipient sub dozatoarele de cafea și apă caldă și sub distribuitorul de abur (A6) (fig. 44).
4. Rotiți butonul (B8) spre (fig. 45): indicatorul luminos OK se aprinde în culoarea portocaliu: indicatorul luminos clipește
5. Apăsăți tasta OK: indicatorul luminos OK clipește.
6. Programul de decalcifiere începe și lichidul de decalcifiere iese din distribuitor. Programul de decalcifiere execută automat o serie de clătiri la intervale de timp, pentru a îndepărta reziduurile de calcar din interiorul aparatului de preparat cafea până la golirea completă a rezervorului.

Distribuirea se oprește și indicatorul luminos OK devine alb. Prin urmare, este necesar să continuați cu ciclul de clătire:

7. Goliți recipientul folosit pentru colectarea lichidului de decalcifiere și plasați-l sub dozatoare.
8. Scoateți rezervorul de apă, goliți-l de eventuale reziduuri de soluție de decalcifiere, clățiți-l cu apă curentă și umpleți-l cu apă proaspătă până la nivelul MAX (fig. 46). Apoi reintroduceți rezervorul în locul său.











9. Apăsăți tasta OK: începe clătirea.
10. Odată ce clătirea este completă, distribuția se oprește și aparatul este gata de utilizare.
11. Goliți recipientele pentru colectarea apei de clătire.





12. Scoateți și goliți tava pentru colectarea picăturilor, apoi reintroduceți-o.
13. Scoateți și umpleți rezervorul cu apă proaspătă, apoi reintroduceți-l.
- Acum aparatul este gata de utilizare.







Rețineți:



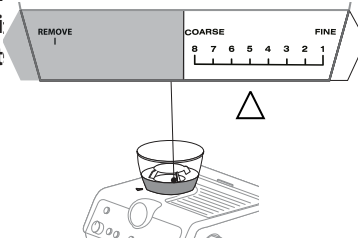

- Ciclul de decalcifiere poate fi pornit oricând (chiar dacă indicatorul luminos corespunzător nu este încă aprins).
- Dacă decalcifierea a fost pornită din greșeală, țineți apăsată tasta OK timp de 10 secunde; clătirea nu poate fi întreruptă.

12. SEMNIFICAȚIA INDICATOARELOR LUMINOASE



INDICATOARE LUMINOASE	SEMNIFICAȚIA INDICATOARELOR LUMINOASE	OPERAȚIUNE
Toate indicatoarele clipeșc scurt	Pornirea aparatului	Diagnosticare automată
 constant	Este prima pornire a aparatului și este necesară umplerea circuitului de apă	Procedați astfel cum este indicat în cap. „3. Prima punere în funcțiune a aparatului”
 constant (alb) • Indicatorul luminos  : indică temperatura cafelei selectate • Indicatorul luminos  : indică faptul că mașina este gata cu distribuitor de apă caldă	Mașina este gata pentru distribuire	Pregătiți mașina și continuați cu prepararea băuturii
 constant	Funcția de economisire a energiei este activă	Consultați cap. „7. Meniu setări” dacă doriți să dezactivați funcția
 constant	Recipientul pentru boabe (A2) este gol	Umpleți recipientul pentru boabe
 intermitentă	Doriți să continuați cu măcinarea, dar recipientul pentru boabe (A2) este gol	Umpleți recipientul pentru boabe
 clipește intermitent scurt la intervale regulate	Butonul (B2) este rotit în poziția de reglare maximă 	Când după măcinare, cafeaua din filtru este insuficientă, selectați un nou interval de măcinare astfel cum este indicat în capitolul „7. Meniu setări”.
 constant	Nu există suficientă apă în rezervorul (A14) sau rezervorul de apă nu este bine introdus	Reumpleți rezervorul sau scoateți-l și reintroduceți-l în mod corect
		→

INDICATOARE LUMINOASE	SEMNIIFICAȚIA INDICATOARELOR LUMINOASE	OPERAȚIUNE
 intermitentă	Doriți să continuați cu pregătirea unei băuturi, dar rezervorul de apă (A14) este gol	Umpleți rezervorul cu apă
	Măcinarea este prea fină, iar din acest motiv cafeaua curge foarte lent sau nu curge toată	Scoateți cupa suportului de filtru (C1), repetați operațiunile de preparare a cafelei, ținând cont de indicațiile de la par. „4.1 Faza 1 - Măcinare (grinding)” și „4.2 Faza 2 - Presare (tamping)”
	Filtrul de cafea (C2) sau (C3) este înfundat	Clătiți filtrele cu apă de la robinet
	Rezervorul (A14) nu este introdus corect și supapele corespunzătoare nu sunt deschise	Apăsați ușor rezervorul pentru a deschide supapele
	Calcar în interiorul circuitului de apă	Executați decalcifierea conform cap. „11. Decalcifiere”.
 constant	Aparatul este gata să distribuie abur	Aparatul a atins temperatura pentru a distribui abur. Pentru a continua distribuirea, rotiți butonul pentru abur (A4)
 intermitentă	Aparatul este pornit, iar funcția de economisire a energiei este activă: butonul de abur (A4) este în poziția de distribuire a aburului	Indicatorul clipește pentru a indica faptul că aparatul se pregătește să distribuie abur: distribuirea începe imediat ce aparatul este în stare de funcționare
	Aparatul este gata să distribuie abur	Aparatul este la temperatura de preparare a aburului atunci când indicatorul luminos rămâne aprins constant
	Aparatul distribuie abur	
 constant	Recipientul pentru boabe nu este introdus	Introduceți corect recipientul pentru boabe (A2) sau verificați dacă este introdus corect. Recipientul este introdus corect când săgeata ▲ este aliniată cu simbolul ☞ și se aude un „clac”
→		

INDICATOARE LUMINOASE	SEMNIIFICAȚIA INDICATOARELOR LUMINOASE	Operațiune
 intermitentă	<p>Reglarea selectorului gradului de măcinare nu este corectă sau depășește setarea maximă posibilă</p> <p>ÎN AFARA intervalului corect</p>  <p>Interval corect range</p>	<p>Întoarceți selectorul într-una din pozițiile de măcinare (între 1 și 8), amintindu-vă că:</p> <ul style="list-style-type: none"> • Reglați măcinarea în timp ce râșnița de cafea este în funcțiune • Reglați un nivel pe rând și faceți cel puțin 5 măcinări între o reglare și următoarea
 constant	<p>Aparatul necesită efectuarea fazei de presare</p> <p>Suportul de filtru a fost decuplat de la lama de măcinare fără să fi efectuat presarea</p> <p>Suportul de filtru a fost decuplat, fără a se finaliza măcinarea, sau presarea s-a efectuat prea devreme</p> <p>Ștuțul de cafea al râșniței este înfundat</p> <p>Lamele de măcinare sunt blocate de un corp străin</p>	<p>Tocmai a fost efectuată măcinarea, iar suportul pentru filtru a fost fixat pe aparatul de cafea</p> <p>Decuplați suportul filtrului și continuați cu presarea cafelei, conform instrucțiunilor din par. „Doza perfectă” „Dacă se utilizează cafea pre-măcinată.”</p> <p>Repetăți operațiunea de măcinare</p> <p>Continuați să curățați astfel cum este indicat în par. „8.5 Curățarea „Smart tamping station”. Dacă problema persistă, accesați ștuțul, deschizând ușița și eliberând-o folosind peria</p> <p>Îndepărtați corpul străin și curățați lamele de măcinare astfel cum este indicat în par. „8.3 Curățarea râșnițelor”.</p>
 constant (roșu)	<p>Este necesar să continuați procesul de decalcifiere</p>	<p>Efectuați decalcifierea după cum este ilustrat în cap. „11. Decalcifiere”</p>
 intermitent (roșu) +  intermitent (portocaliu)	<p>Aparatul efectuează operația de decalcifiere</p>	<p>Continuați prin terminarea operațiunii așa cum este descris în cap. „11. Decalcifiere”</p>
 intermitent (roșu) +  constant (alb)	<p>Este necesar să continuați cu clătirea</p>	
→		

INDICATOARE LUMINOASE	SEMNIIFICAȚIA INDICATOARELOR LUMINOASE	Operațiune
 intermitent (roșu) +  intermitent (alb)	Aparatul efectuează clătirea ciclului de decalcifiere	
 constant (portocaliu)	Este necesar să continuați să curățați dozatorul de cafea	A se vedea par. „8.1 Curățarea dozatorului de cafea”
 intermitentă (portocalie)	Aparatul curăță dozatorul de cafea	
Toate indicatoarele luminoase clipește intermitent	Alarmă generală	Adresați-vă unui centru de asistență

13. DACĂ CEVA NU FUNCȚIONEAZĂ

PROBLEMĂ	CAUZĂ	SOLUȚIE
Există apă în tava de colectare a picăturilor (A10)	Face parte din funcționarea normală a circuitelor interne ale mașinii	Goliți și curățați tava de colectare a picăturilor în mod regulat
Nu mai curge cafeaua espresso	Lipsa apei în rezervor (A14)	Umpleți rezervorul
	Indicatorul luminos  (B6) se aprinde, indicând faptul că circuitul de cafea sau cel de abur este gol	Apăsăți tasta din dreapta indicatorului luminos  pentru a umple circuitul
	Filtrul (C2) sau (C3) este blocat	Clătiți filtrele cu apă de la robinet
	Rezervorul (A14) nu este bine introdus și supapele din partea de jos nu sunt deschise	Apăsăți ușor rezervorul, astfel încât să se deschidă supapele din partea de jos
	Calcar în interiorul circuitului de apă	Executați decalcifierea conform cap. „11. Decalcifiere”.
	Măcinarea este prea fină	Scoateți cupa suportului de filtru (C1), repetați operațiunile de preparare a cafelei, ținând cont de indicațiile de la par. „4.1 Faza 1 - Măcinare (grinding)” și „4.2 Faza 2 - Presare (tamping)”
Suportul de filtru nu se atașează la aparat	Cafeaua măcinată nu a fost presată sau este prea multă	Repetăți măcinarea cu diferite setări. Reduceți cantitatea dozei: verificați dacă filtrul (C2) sau (C3) (1 sau 2 cești) este corect pentru doza care trebuie măcinată (butonul 2x (B3) este selectat sau nu)
Cafeaua espresso se scurge de pe marginea suportului de filtru (C1) în loc să se scurgă din orificii	Suportul de filtru nu este bine introdus	Introduceți corect suportul de filtru și rotiți-l cu putere până la capăt
	Garnitura dozatorului de cafea (A18) și-a pierdut elasticitatea sau este murdară	Înlocuiți garnitura dozatorului de cafea la un centru de service
	Filtrul (C2) sau (C3) este blocat	Clătiți filtrele cu apă de la robinet
→		

PROBLEMĂ	CAUZĂ	SOLUȚIE
Crema cafelei este deschisă la culoare (curge prea repede din duză)	Este necesar să revizuiți setările aparatului	Scoateți cupa, repetați operațiunile de preparare a cafelei, ținând cont de indicațiile din par. „4.1 Faza 1 - Măcinare (grinding)” și „4.2 Faza 2 - Presare (tamping)”
Crema cafelei are o culoare închisă (cafeaua curge lent din duză)	Este necesar să revizuiți setările aparatului	Scoateți cupa suportului de filtru (C1), repetați operațiunile de preparare a cafelei, ținând cont de indicațiile de la par. „4.1 Faza 1 - Măcinare (grinding)” și „4.2 Faza 2 - Presare (tamping)”
La terminarea ciclului de decalcifiere, aparatul necesită o nouă clătire	În timpul ciclului de clătire, rezervorul nu a fost umplut până la nivelul MAX	Repetăți clătirea (a se vedea cap. „11. Decalcifiere”)
Aparatul nu macină cafeaua	Există un corp străin în râșnița de cafea	Continuați să curățați moriștile astfel cum este indicat în par. „8.3 Curățarea râșnițelor”, asigurându-vă că ați îndepărtat toate boabele din recipientul pentru boabe (A2) înainte de a-l scoate. Înainte de a reintroduce râșnița, aspirați cu grijă orice reziduu din locaș
	Recipientul pentru boabe (A2) nu se află în poziție corectă	Recipientul este introdus corect când săgeata ▲ este aliniată cu simbolul ☪ și se aude un „clic”
Dacă se dorește modificarea calității cafelei	Este necesară îndepărtarea tuturor boabelor prezente în aparat	<ul style="list-style-type: none"> • Goliți recipientul pentru boabe (A2) (efectuând cicluri de măcinare în gol sau, eventual, aspirând boabele rămase) • Fixați cupa pentru suportul filtrului (C1) și efectuați o măcinare „în gol” pentru a elibera tubul de cafea: fixați apoi suportul filtrului la orificiul de ieșire al râșniței (A19), aliniindu-l cu mesajul INSERT și răsucind cupa spre dreapta. Măcinarea începe când cupa ajunge în poziția CLOSE și se întrerupe automat. Repetați până când filtrul rămâne gol • Introduceți noua varietate de boabe de cafea în recipientul (A2) • Dacă „doza perfectă” nu este atinsă în timpul măcinării, procedați ca la prima utilizare
		→

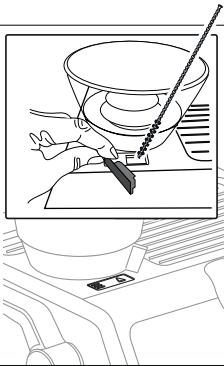
PROBLEMĂ	CAUZĂ	SOLUȚIE
<p>După măcinare, filtrul de cafea (C2) sau (C3) este gol</p> <p>După măcinare, pulberea de cafea din filtru este superabundentă</p>	<p>Ștuțul de cafea al râșniței este înfundat</p>	<p>Continuați să curățați astfel cum este indicat în par. „8.5 Curățarea „Smart tamping station””. Dacă problema persistă, accesați ștuțul deschizând ușița (A21) și eliberând-o folosind peria</p> 
<p>După măcinare, pudra de cafea din filtrul (C2) sau (C3) nu atinge „doza perfectă”</p>	<p>Este necesară curățarea "Smart Tamping Station"</p> <p>Este necesară reglarea cantității de cafea măcinată</p> <p>În timp, lamele de măcinare se uzează</p>	<p>Continuați să curățați astfel cum este indicat în par. „8.5 Curățarea „Smart tamping station””, apoi repetați măcinarea</p> <p>Reglați cantitatea, folosind butonul rotativ aferent (B2) și urmând instrucțiunile din par. „Doza perfectă”. Dacă butonul este deja în poziția maximă, procedați conform indicațiilor din secțiunea „7. Meniu setări” – „Reglare suplimentară a măcinării”</p> <p>Înlocuiți lamele de măcinare, urmând indicațiile din par. „8.4 Înlocuirea lamelor de măcinare”</p>

المشكلة	السبب	الحل
بعد عملية الطحن مرشح القهوة (C2) أو (C3) فارغ بعد عملية الطحن، يكون غبار البن غزير في المرشح	يكون مسار البن في ماكينة طحن البن مسدود	قم بتنظيفه كما هو مبين في الفقرة «8.5 تنظيف «Smart tamping station». إذا ما استمرت المشكلة ادخل إلى المنزلق عبر فتح المنفذ الصغير (A21) المعد خصيصًا لذلك ثم حرره باستخدام فرشاة التنظيف
بعد عملية الطحن مسحوق القهوة في المرشح (C2) أو (C3) لا يصل إلى «الكمية المثالية»	يحتاج "خزان الطحن الذكي" للتنظيف	قم بتنظيفه كما هو مبين في الفقرة «8.5 تنظيف «Smart tamping station»، ثم كرر عملية الطحن
يلزم ضبط كمية البن المطحون	اضبط الكمية بواسطة مقبض مخصص (B2) مع اتباع الإرشادات الموجودة في الفقرة. «الكمية المثالية». إذا كان المقبض بالفعل في وضع الحد الأقصى، اعمل على النحو المشار إليه في القسم «7. قائمة إعدادات الضبط» - «ضبط إضافي للطحن»	
بمضي الوقت تتهالك شفرات المطحنة	اشرع في استبدال رجلي المطحنة كما هو مبين في الفقرة «8.4 استبدال أحجار الطحن»	

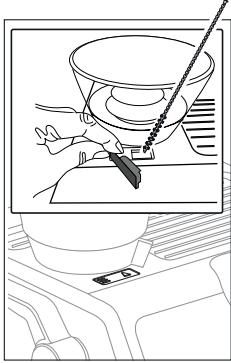

المشكلة	السبب	الحل
كريمة القهوة فاتحة اللون (تدفق بشكل سريع من الصنبور)	يجب بالضرورة مراجعة إعدادات ضبط الجهاز	استخرج الكوب، وكرر العمليات لعمل القهوة مع اتباع التعليمات الواردة في الفقرة. "4.1 المرحلة 1 - الطحن (grinding)" و "4.2 المرحلة 2 - الضغط (tamping)"
كريمة القهوة داكنة اللون (القهوة تتدفق بشكل بطئ من الصنبور)	يجب بالضرورة مراجعة إعدادات ضبط الجهاز	استخرج كأس حامل المرشح (C1)، وكرر عمليات إعداد القهوة مع اتباع التعليمات الواردة في الفقرة. «4.1 المرحلة 1 - الطحن (grinding)» و «4.2 المرحلة 2 - الضغط (tamping)»
بمجرد انتهاء عملية إزالة الترسبات الكلسية، سيقوم الجهاز بدورة الشطف الثالثة	أثناء دوري الشطف، لا يكون خزان الماء ممتلئًا بالماء حتى المستوى الأقصى MAX	كرر عملية الشطف (انظر الفصل "1.11 التخلص من الترسبات")
الجهاز لا يطحن القهوة	هناك جسم غريب داخل مطحنة البن	ابدأ في عملية الطحن كما هو مُحدّد في الفقرة. «8.3 تنظيف رحي المطحنة»، مع التحقق من إزالة جميع الحبوب من وعاء الحبوب (A2) قبل استخراجها. قبل إعادة إدخال حجر الطحن، قم بشطف أية بقايا بعناية من مكان حجر الطحن
حماية حبوب القهوة (A2) غير موجودة في الوضعية الصحيحة	تصحح الحاوية موضوعة بالشكل الصحيح في مكانها عندما يكون السهم ▲ مضبوط المحاذاة مع الرمز  وعند سماع صوت "نقرة"	
إن كنت ترغب في تغيير جودة القهوة	يلزم إزالة جميع حبوب البن الموجودة في الماكينة	<ul style="list-style-type: none"> • أفرغ حاوية حبوب القهوة (A2) عن طريق الطحن الفارغ أو ربما شطف الحبوب المتبقية) • ثبت كأس حامل المرشح (C1) و نفذ عملية طحن "على الفارغ" من أجل تحرير مسار القهوة؛ ثم ثبت حامل المرشح في مخرج مطحنة البن (A19) عن طريق محاذاة بالكتابة INSERT (إدخال) وأدر الكأس تجاه اليمين. تبدأ عملية الطحن عندما يصل الكوب إلى الوضع "غلق" CLOSE وتتوقف تلقائيًا. • كرر العملية حتى يصبح المرشح فارغًا • أدخل في الحاوية (A2) نوعية حبوب القهوة الجديدة • غدا لم يتم الوصول إلى "الكمية المثالية" عند الطحن، قم بإجراء الاستخدام الأول للماكينة







لمبات التنبيه	معنى المؤشرات	العملية
 يومض (أحمر) + يوميض (برتقالي) (OK)	ينفذ الجهاز عملية إزالة الترسبات الكلسية	قمر باستكمال العملية كما هو موضح في الفقرة. "11". التخلص من الترسبات"
 يومض (أحمر) + ثابت الإضاءة (أبيض) (OK)	من الضروري القيام بالشطف	
 يومض (أحمر) + يوميض (أبيض) (OK)	يقوم الجهاز بتنفيذ شطف دورة إزالة الترسبات الكلسية	
 ثابتة الإضاءة (باللون البرتقالي)	يجب بالضرورة إجراء عملية تنظيف لموزع سكب القهوة	انظر الفقرة "8.1" تنظيف موزع سكب القهوة"
 توميض (باللون البرتقالي)	الجهاز يقوم الآن بتنظيف موزع سكب القهوة	
جميع المؤشرات تومض	الإنذار العام	توجه إلى مركز الدعم الفني

13. إذا حدث وتعرض شيء ما للتعطل

المشكلة	السبب	الحل
هناك ماء في حوض تجميع القطرات (A10)	إنه جزء من التشغيل الطبيعي للدوائر الداخلية في الماكينة	قمر بتفريغ وتنظيف حوض تجميع القطرات بانتظام
لم تعد تخرج القهوة الإسبرسو	ربما بسبب قلة الماء في الخزان (A14)	املا الخزان
	المؤشر  (B6) مضيء للإشارة إلى أن دائرة القهوة أو دائرة البخار فارغة	اضغط على المفتاح الموافق للمؤشر  لملء الدائرة
	المرشح (C2) أو (C3) مسدود	اشطف المرشحات تحت الماء الجاري
	تم تركيب الخزان (A14) بشكل خاطئ و الصمامات في القاع غير مفتوحة	اضغط بلطف على الخزان حتى يتم فتح الصمام الذي في القاع
	تكون ترسبات كلسية في الدائرة المائية	قمر بتنفيذ إزالة الترسبات الكلسية على النحو الوارد في فصل. "11". التخلص من الترسبات"
	الطحن المفرطة النعومة	استخرج كأس حامل المرشح (C1)، وكرر عمليات إعداد القهوة مع اتباع التعليمات الواردة في الفقرة. "4.1 المرحلة 1 - الطحن (grinding)" و "4.2 المرحلة 2 - الضغط (tamping)"
حامل المرشح غير مثبت جيداً في الجهاز	لم يتم الضغط على القهوة المطحونة أو كمية القهوة المفرطة	كرر عملية الطحن بإعدادات ضبط مختلفة، قلل كمية القهوة؛ تحقق من أن المرشح (C2) أو (C3) (1) أو 2 فنجان) مناسب من حيث الكمية المراد طحنها (الزر (B3) 2x مختار أمر لا)
القهوة الإسبرسو تنقطر من على جوانب حامل المرشح (C1) بدلاً من الثقوب	حامل المرشح مركب بشكل خاطئ	ثبّت حامل المرشح بالشكل الصحيح ثم لقه بقوّة حتّى النهاية
	حشوة إحكام غلق موزع سكب القهوة (A18) فقدت مرونتها أو متسخة	استبدل حشوة إحكام غلق موزع سكب القهوة لدى أحد مراكز الصيانة والدعم الفني
	المرشح (C2) أو (C3) مسدود	اشطف المرشحات تحت الماء الجاري

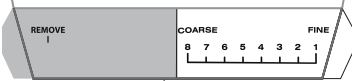
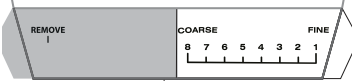

لمبات التنبيه	معنى المؤشرات	العملية
	الجهاز مشغل ووظيفة توفير الطاقة نشطة: مبيض البخار في وضع (A4) إخراج البخار	يومض المؤشر ليشير إلى أن الجهاز يستعد لإخراج البخار: يبدأ الإخراج بمجرد وصول الجهاز إلى درجة الحرارة المناسبة
وامضة 	أصبح الجهاز جاهزاً لسكب البخار	الجهاز يكون قد وصل إلى درجة حرارة إعداد البخار عندما يوقد المؤشر الضوئي بإضاءة ثابتة
	الجهاز يقوم بسكب البخار	
ثابتة الإضاءة 	حاوية حبوب القهوة غير مدخلة	أدخل حاوية حبوب البن (A2) بالشكل الصحيح أو تحقق من أنها مدخلة بالشكل الصحيح. تصبح الحاوية موضوعة بالشكل الصحيح في مكانها عندما يكون السهم ▲ محاذي للرمز □ وعند سماع صوت "تقرة"
	مفتاح اختيار درجة الطحن غير مضبوط بشكل صحيح أو أنه يتجاوز الحد الأقصى للضبط الممكن	أعد ضبط المحدد في إحدى وضعيات الطحن (بين 1 و8) مع الحرص والانتباه لما يلي: ضبط الطحن أثناء عمل مطحنة البن ضبط مستوى واحد في المرة الواحدة وإجراء 5 مرات طحن على الأقل بين كل عملية ضبط وأخرى
وامضة 	النطاق صحيح 	خارج النطاق صحيح 
	يحتاج الجهاز إلى عملية الضغط	تم بالكاد تنفيذ عملية الطحن وحامل المرشح مركب برحى طحن البن
	تم فك حامل المرشح من رحى طحن البن دون الضغط	قم بفك حامل المرشح وشرع في ضغط البن على النحو الموصوف في الفقرة. "الكمية المثالية" في حالة استخدام بن مطحون مُسبقاً."
ثابت الإضاءة 	خرج حامل المرشح من موضعه دون إتمام الطحن أو تم تنفيذ الضغط في وقت مبكر جداً	كرر عملية الطحن
	يكون مسار البن في ماكينة طحن البن مسدود	قم بتنظيفه كما هو مبين في الفقرة "8.5 تنظيف Smart tamping station". إذا ما استمرت المشكلة، ادخل إلى المنزلق عبر فتح المنفذ الصغير المخصص لذلك ثم حرره باستخدام فرشاة التنظيف
	رحى الطحن موقوفة بسبب جسم غريب	أزل الجسم الغريب وقرم بتنظيف رحى الطحن على النحو المشار إليه في الفقرة «8.3 تنظيف رحى المطحنة».
ثابت (أحمر) 	يلزم الشروع في عملية إزالة الترسبات الكلسية	قم بتنفيذ عملية إزالة الترسبات الجيرية كما هو موضح في الفصل "11. التخلص من الترسبات"
←		

لمبات التنبيه	معنى المؤشرات	العملية
تومض جميع المؤشرات قليلاً	تشغيل الجهاز	فحص ذاتي
ثابتة الإضاءة 	إنها أول مرة لتشغيل الماكينة ويلزم الشروع في ملء دائرة الماء	اتباع التعليمات الواردة في الفقرة. "3. استعمال الجهاز لأول مرة"
ثابت (أبيض) OK  <ul style="list-style-type: none"> المؤشر الضوئي  : يشير إلى درجة حرارة القهوة المختارة المؤشر الضوئي  : يشير إلى أن الماكينة جاهزة بصنوبر الماء الساخن 	تكون الماكينة جاهزة للصب	قمر بإعداد الماكينة وابدأ في تحضير المشروب
ثابتة الإضاءة 	وظيفة توفير الطاقة نشطة	ارجع إلى الفصل "7. قائمة إعدادات الضبط" عند الرغبة في إيقاف تفعيل هذه الخاصية
ثابتة الإضاءة 	وعاء حبوب القهوة (A2) فارغ	قمر بملء وعاء الحبوب
وامضة 	هناك رغبة في مواصلة عملية الطحن ولكن حاوية حبوب القهوة (A2) فارغة	قمر بملء وعاء الحبوب
وامض لفترة وجيزة على فترات منتظمة 	تم تدوير المقبض (B2) إلى وضع الضبط الأقصى 	عندما يكون البن في المرشح غير كافي بعد الطحن، اختر نطاق طحن جديد على النحو المشار إليه في الفصل "7. قائمة إعدادات الضبط".
ثابت الإضاءة 	الماء الموجود في الخزان (A14) غير كافي أو خزان الماء غير مدخل بالشكل الجيد	أعد ملء الخزان أو اسحب الخزان وأدخله بشكل صحيح
	هناك رغبة في مواصلة إعداد مشروب ولكن خزان الماء (A14) فارغ	املاً الخزان بالماء
وامضة 	عند طحن البن بشكل نامر للغاية فإن القهوة ستدفق من الماكينة ببطء شديد أو قد لا تخرج على الإطلاق	استخرج كأس حامل المرشح (C1)، وكرر عمليات إعداد القهوة مع اتباع التعليمات الواردة في الفقرة. «4.1 المرحلة 1 - الطحن (grinding)» و «4.2 المرحلة 2 - الضغط (tamping)»
	مرشح القهوة (C2) أو (C3) مسدود	اشطف المرشحات تحت الماء الجاري
	تم تركيب الخزان (A14) بشكل خاطئ والصمامات الخاصة به غير مفتوحة	اضغط بلطف على الخزان حتى يتم فتح الصمامات الخاصة به
	تكون ترسبات كلسية في الدائرة المائية	قمر بتنفيذ إزالة الترسبات الكلسية على النحو الوارد في فصل. "11. التخلص من الترسبات"
ثابتة الإضاءة 	أصبح الجهاز جاهزاً لسكب البخار	وصل الجهاز إلى درجة الحرارة المحددة لسكب البخار. لبدء عملية السكب قمر بلف مقبض البخار (A4)



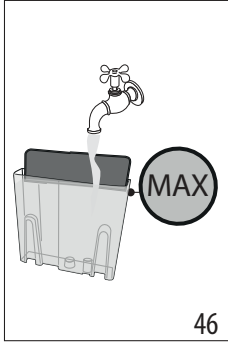

46

علبة سعة 100 مل) المطبوع على الجانب الداخلي من الخزان (الشكل 42).



42

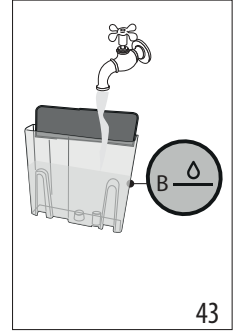

43

9. استمر في الضغط على المفتاح OK: سيبدأ الشطف.
10. بعد اكتمال عملية الشطف، ستتوقف عملية السكب وسيصبح الجهاز جاهزًا للاستخدام.
11. قم بتفريغ وعاء تجميع مياه الشطف.
12. استخرج وفرغ صينية تجميع القطرات، ثم أعد تركيبها.
13. استخرج وأملأ الخزان بالماء البارد، ثم أعد إدراجه.
- الآن أصبحت الماكينة جاهزة للاستعمال.

انتبه جيدًا!

- يمكن بدء دورة إزالة الترسبات الكلسية في أية لحظة (حتى إن لم يضيء بعد المؤشر المتعلق بها).
- في حالة بدء عملية إزالة الترسبات الجيرية عن طريق الخطأ، اضغط على المفتاح OK لمدة 10 ثوانٍ؛ لا يمكن إيقاف عملية الشطف.

2. أضف الماء حتى الوصول إلى المستوى B (الشكل 43). ثم أعد إدخال الخزان في موضعه على الماكينة.

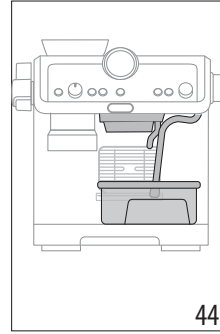

44

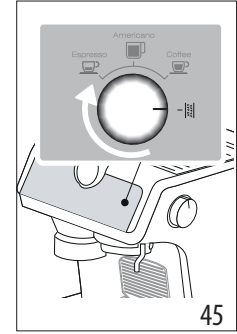

45

3. تحقق من أن حامل المرشح (C1) ليس مثبت تعشيقًا وضع وعاءً تحت صنبوري القهوة والماء الساخن وتحت صنبور البخار (A6) (الشكل 44).
4. أدر المقبض (B8) إلى (الشكل 45): يضيء المؤشر الضوئي OK باللون البرتقالي؛
5. اضغط على المفتاح OK: سيومض المؤشر (B8).
6. سيبدأ برنامج إزالة الترسبات الجيرية وسيخرج سائل مزيل الترسبات الجيرية من موزعات السكب. يقوم برنامج إزالة الترسبات الكلسية تلقائيًا بسلسلة من الشطف على فترات، بغرض إزالة البقايا الكلسية من داخل ماكينة إعداد القهوة حتى يتم إفراغ الخزان تمامًا.
- تتوقف عملية السكب ويصبح المؤشر الضوئي OK أبيض اللون. يصبح بالتالي من الضروري إجراء دورة شطف:
7. قم بتفريغ الوعاء المستخدم من أجل تجميع سائل إزالة الترسبات وضعه تحت الموزعات.
8. أزل خزان الماء وفرّغه من البقايا المحتملة من سائل إزالة الترسبات الكلسية، واشطفه بالماء الجاري، وأعد ملئه بماء بارد حتى مستوى MAX (الشكل 46). ثم أعد إدخال الخزان في موضعه.

1. أخرج علبة Softballs من العبوة (الشكل 38).

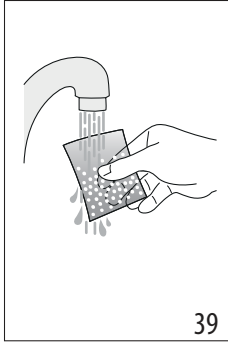
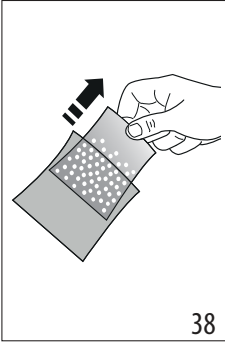

2. اشطفْ علبة Softballs بماء جارٍ (الشكل 39).

3. اغمس الكيس في خزان الماء (A14) (الشكل 40).

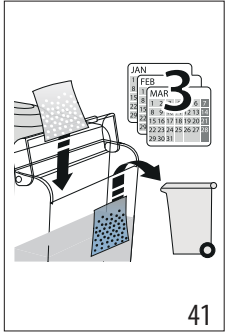
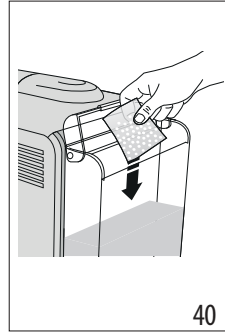

4. استبدل كيس Softballs كل 3 أشهر (الشكل 41).

11. التخلص من الترسبات

انتبه!

- قبل البدء في استخدام مزيل الترسبات الجيرية (C5)، يجب قراءة التعليمات والإرشادات الخاصة به والواردة على علبة هذا المزيل نفسه.
- من المستحسن استخدام فقط وحصرًا مزيل الترسبات الكلسية De'Longhi. تجدر الإشارة هنا إلى أن استخدام أي مزيل للترسبات الكلسية آخر غير مناسب، فضلا عن عدم إزالة الترسبات الكلسية بشكل منتظم، يؤدي إلى حدوث عيوب لا يغطيها الضمان الخاص بجهة التصنيع.
- يمكن أن يسبب مزيل الترسبات تلف الأسطح الحساسة. في حالة انسكاب المنتج عن طريق الخطأ، جففه على الفور.

من أجل تنفيذ غزالة الترسبات الكلسية	
مزيل الترسبات الكلسية	مزيل الترسبات الكلسية ديلونجي
الوعاء	السعة 2 لتر
الزمن	~40 دقيقة

1. (أزل مرشح تيسير الماء و SOFTBALLS، إن وُجدوا). اسكب في خزان الماء (A14) مزيل الترسبات الجيرية حتى المستوى **A** (ما يقابل

ضبط الكمية (B2) في وضعية الحد الأدنى MIN ثم اضبط الكمية كمرّة الاستخدام الأولى (انظر «الكمية المثالية»).

8.5 تنظيف "Smart tamping station"

1. قمر بتنظيف منطقة الربط بفرشاة (الشكل 35).
2. اسحب الذراع (A20) حتى نهاية مساره ونظّف الضاغط بواسطة فرشاة (الشكل 36)، ثم حرر الذراع.
3. باستخدام منظف الأنايب (C7)، قمر بتنظيف مسار البن (الشكل 37).

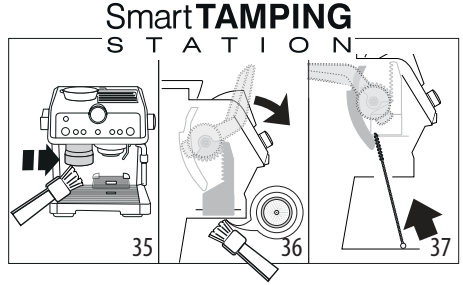

9. عسر الماء

يُضاء المؤشر الضوئي (B9) لإزالة الترسبات بعد فترة محددة من التشغيل الذي يعتمد على عسر المياه. يمكن برمجة الماكينة وفقًا للمستوى الحقيقي لعسر الماء المستخدم في المناطق المُختلفة، الأمر الذي سيقلل من وتيرة القيام بعملية إزالة الترسبات الكلسية.

1. أزل الشريط التفاعلي الوارد مع الجهاز من العبوة الخاصة به "إجمالي عسر الماء" (C4) TOTAL HARDNESS TEST.
2. اغمر الشريط تمامًا في كوب من الماء لمدة ثانية تقريبًا.
3. أخرج الشريط بعد ذلك من الماء ثم مرّه قليلًا. اضبط إعدادات الجهاز كما هو موضح في الفصل «7. قائمة إعدادات الضبط».

مستوى	الزر	نتيجة اختبار عسر الماء
1 ماء عذب	×2	
2 مياه متوسطة العسر	≡	
3 ماء عسير أو عسير جدًا	OK	

4. اضبط إعدادات الجهاز كما هو موضح في الفصل «7. قائمة إعدادات الضبط».

10. كيفية استخدام SOFTBALLS

(C9) Softballs هو نظام مبتكر يطيل من العمر التشغيلي للماكينة دون أن يؤثر سلبيًا على كمية المياه مما يضمن عملية سكب للقهوة كريمية ومفعمة بالنكهة. لتحسين الكفاءة التشغيلية اترك Softballs في الماء طوال الليلة السابقة للاستخدام.

8.2 قمر بتنظيف مكان وضع حاوية حبوب القهوة

1. تحقق من أن حاوية حبوب القهوة (A2) فارغة. قمر إن أمكن بإجراء بعض عمليات الطحن والحاوية فارغة لتفريغها.
2. قمر بفاك تعشيق الحاوية عبر لفها في عكس اتجاه عقارب الساعة ثم أخرجها من الماكينة (الشكل 27)
3. اشطف بقايا القهوة (الشكل 28).
4. استخدم قطعة قماش رطبة لتنظيف مكان حاوية حبوب القهوة ثم قمر بالتنظيف (الشكل 29):
5. أعد وضع الوعاء عن طريق إدخاله في مطحنة البن. تصح الحاوية موضوعة بالشكل الصحيح في مكانها عندما يكون السهم ▲ محاذي للرمز □ وعند سماع صوت "نقرة" (الشكل 30).

8.3 تنظيف رحي المطحنة

- عند تنظيف حاوية حبوب القهوة (A2)، قمر أيضًا بتنظيف مكان الحاوية ورحى المطحنة العلوي باستخدام قطعة قماش رطبة. توجه إلى أحد مراكز الدعم الفني المعتمدة لإزالة واستبدال رحي الطحن.
- يمكن إزالة رحي الطحن عند توقف مطحنة البن عن العمل جراء وجود جسم غريب. وفي حالة حدوث ذلك قمر بإزالة حاوية حبوب القهوة وقمر بما يلي:
1. قمر تعشيقًا بثبتي كأس حامل المرشح (C1) ثم قمر بإجراء عملية طحن "على الفارغ" لتحرير أنبوب القهوة.
 2. أطفئ الجهاز.
 3. قمر بلف مقبض ضبط الطحن في عكس اتجاه عقارب الساعة حتى نهاية المسار، في وضع "REMOVE (إزالة)" (الشكل 31).
 4. أخرج الجزء العلوي من رحي الطحن، من خلال الإمساك بها من المقبض المخصص لذلك (الشكل 32).
 5. نظف المطحنة بفرشاة (الشكل 33)، واشطف بقايا البن بالمكنسة الكهربائية (الشكل 34).

×	×	✓	✓	×	
✓	✓	×	×	✓	
✓	✓	×	×	×	
✓	✓	×	×	×	
×	✓	✓	×	×	
✓	✓	×	×	×	

8.1 تنظيف موزع سكب القهوة

عندما يوقد المؤشر الضوئي ☼ (باللون البرتقالي) (B13)، فإنه يصبح من الضروري البدء في تنظيف دائرة إعداد القهوة. لإجراء عملية النظافة قمر بشراء أقراص تنظيف ماكينات إعداد القهوة. لمزيد من المعلومات حول ذلك، قمر بزيارة الموقع الإلكتروني www.Delonghi.com.

1. أدخل المرشح 1 فنجان (C2) في حامل المرشح (C1) (الشكل 25).
2. ادخل ملحق التنظيف (C8) في المرشح (الشكل 25) ثم اضغط عليه بالكامل.
3. ضع قرص التنظيف على الملحق التشغيلي (الشكل 26).
4. قمر بتوصيل حامل المرشح بموزع سكب القهوة (A18).
5. أعد ملء خزان الماء (A14). تحقق من أن حوض تجميع القطرات (A10) فارغ.
6. استمر في الضغط على المفتاح (B6)، حتى يضيئ المؤشر الضوئي ☼ (B13). بعد بضعة دقائق، تتوقف عملية التنظيف بشكل تلقائي.
7. قمر بإزالة حامل المرشح وملحق التنظيف.
8. اغسل حامل المرشح والمرشح تحت تيار ماء جارٍ.
9. أعد إدخال حامل المرشح ثم ابدأ في عملية شطف بالضغط على المفتاح ؛ يُنصح بوضع وعاء تحت حامل المرشح.
10. قمر بإزالة وتفريغ حوض تجميع القطرات.

انتبه جيدًا:

يمكن بدء دورة التنظيف هذه في أية لحظة بالضغط على المفتاح لبضع ثوانٍ. لإلغاء هذه العملية اضغط على الزر لمدة 10 ثوانٍ.

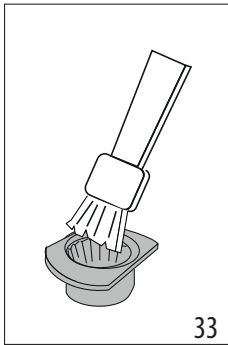

33

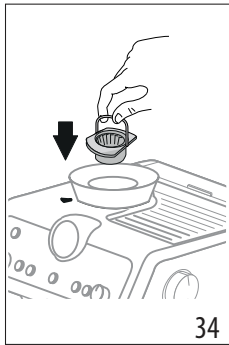

34

6. أدخل رحي المطحنة في مبيته (الشكل 34):
 7. أدر مقبض الضبط لاختيار درجة الطحن المرغوبة (الشكل 14):
- تحقق من أن رحي المطحنة مركبة جيدًا، من خلال سحبها من المقبض؛ إذا لم تتحرك الرحي، فهي مركبة بشكل صحيح.

8.4 استبدال أحجار الطحن

عند انخفاض كمية القهوة المطحونة توجه إلى أحد مراكز الصيانة والدعم الفني المعتمدة لاستبدال رحي الطحن؛ ثم اضغط من جديد مطحنة البن عبر الدخول إلى قائمة إعدادات الضبط («7. قائمة إعدادات الضبط») وتحديد النطاق الأول للضبط "extra" للطحن. قمر بعد ذلك بلف مقبض

ضبط إضافي للطنن	Espresso	2 × ← النطاق 1
		☰ ← النطاق 2
عسر الماء	Americano	2 × ← غير عسر
		☰ ← متوسط
		OK ← عسر/عسر جدًا
الإيقاف الأوتوماتيكي للتشغيل	Coffee	2 × ← 9 دقائق
		☰ ← 1,5 ساعة
		OK ← 3 ساعات

3. الضبط مع الاختيار من المفتاح:

وظيفة ترشيد استهلاك الطاقة	☰ ← مفعلة	
	☰ ← مطفأة	
قيم المصنع		استمر في الضغط على المفتاح (my) لمدة 5 ثوان حتى يظل المؤشر الضوئي مضيئاً بشكلٍ ثابت

4. احفظ إعدادات الضبط الجديدة بالضغط على ON/Standby (B1)

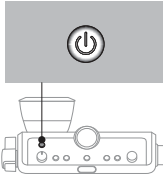

8. تنظيف الجهاز

انتبه!

- لتنظيف الماكينة، لا تستعمل مذيبات أو منظفات مُسببة للتآكل أو الكحول.
- لا تستخدم الأشياء المعدنية في إزالة القشور الترسبية ولا راسب وبقايا القهوة لأنها يمكن أن تتسبب في خدش الأسطح المعدنية أو البلاستيكية في الماكينة.
- بالنسبة لفترات عدم الاستخدام التي تزيد عن أسبوع يُصح، قبل استخدام الماكينة، القيام بعملية شطف.

خطر!

- أثناء التنظيف، لا تعمر الماكينة أبدًا في الماء؛ إنها جهاز كهربائي.
- قبل الشروع في أي عملية تنظيف للأجزاء الخارجية للجهاز، أطفئ أولاً الماكينة، افصل القابس من مصدر التيار الكهربائي ثم اترك الماكينة حتى تبرد.

5. بعد الحصول على الكمية المطلوبة، اضغط OK. إذا كان المشروب يحتاج إلى سكب مكوّن آخر فإنه سيبدأ سكب هذا المكوّن: بعد الوصول إلى الكمية المطلوبة، اضغط OK.
6. اضغط على الزر (my) للحفاظ. للجهاز أصبح جاهزًا للاستخدام من جديد والمؤشر الضوئي (my) سيبقى موقّدًا. عند الرغبة في عدم حفظ البرنامج اضغط على أي زر آخر.

انتبه جيدًا:

- يمكن برمجة المشروبات مع القهوة ولكن ليس عملية سكب البخار والماء الساخن.
- تقوم عملية البرمجة بتعديل كميات المشروبات ولكن ليس كميات القهوة المطحونة.
- المشروبات "X2" يمكن برمجتها بشكل منفصل.
- من أجل العودة إلى إعدادات المصنع، استمر في الضغط على المفتاح (my) حتى الإطفاء. يعود المشروب المختار إلى الكمية الافتراضية المضبوطة في المصنع.

وصفة إعداد القهوة	الكمية الافتراضية المضبوطة في المصنع	الكمية القابلة للبرمجة
Espresso	35 مل	من 25 إلى 90 مل
X2 Espresso	70 مل	من 50 إلى 180 مل
Coffee	80 مل	من 50 إلى 120 مل
X2 Coffee	160 مل	من 120 إلى 240 مل
Americano	120 مل	• إسبريسو: من 25 إلى 60 مل • ماء: من 25 إلى 120 مل
X2Americano	240 مل	• إسبريسو: من 50 إلى 120 مل • الماء: من 50 إلى 240 مل

7. قائمة إعدادات الضبط

1. ادخل في القائمة:		
(my)	x2	اضغط في نفس الوقت لمدة 5 ثوان
2. الإعدادات مع الاختيار من المقبض (B8)		
إعدادات الضبط	أدر على	إعدادات الضبط المقابلة
←		

22. للحصول على رغوة أكثر كثافة وتجانساً، يُصح باستخدام حليب بقرى كامل الدسم وبدرجة حرارة التلاجة (تقريباً 5° مئوية).

My Latte Art

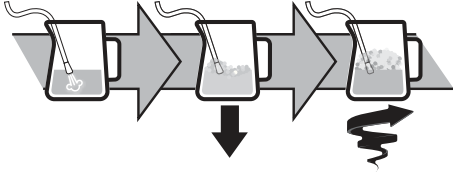

2. لترغية الحليب قم بسند أنبوب موزع سكب البخار (A6) على سطح الحليب: بهذه الطريقة سيمتزج الهواء مع الحليب والبخار.
3. ابقِ على موزع سكب البخار على السطح مع ضرورة الانتباه حتى لا تحجز كمية المفرطة من الهواء مما قد يكون فقاعات هوائية مفرطة الكبر.
4. اغمس موزع سكب البخار تحت سطح الحليب: بهذه الطريقة ستحصل على قمة بارزة. بعد الوصول إلى درجة الحرارة المطلوبة أعد غلق مقبض البخار ثم انتظر حتى يتوقف سكب البخار بشكل كامل قبل إزالة وعاء الحليب.

يوصى عامل البار بما يلي:

- **الحليب الطازج أفضل.** استعمل دائماً حليباً طازجاً بدرجة حرارة التلاجة.
- للحصول على أفضل نتيجة، يُصح دائماً بإعادة وضع إبريق الحليب في التلاجة.
- الحليب الكامل الدسم يضمن الحصول على نتائج مثالية. شكل وقوام الرغوة يختلفان باختلاف الحليب البقري أو المشروبات النباتية المستخدمة.
- بعد ترغية الحليب، أزل الفقاعات عن طريق تدوير إبريق الحليب قليلاً.

تنظيف موزع سكب البخار:

1. بعد كل استخدام، قم بإزالة بقايا الحليب من موزع سكب البخار باستخدام قطعة قماش (الشكل 23). لإجراء عملية تنظيف عميقة يُصح باستخدام Eco MultiClean: إنه يضمن النظافة المطلوبة حيث يزيل بروتينات ودهون الحليب ويمكن استخدامه لتنظيف الماكينة بأكملها.
2. اسكب البخار لبضع ثوانٍ لتنظيف موزع السكب جيداً (الشكل 12).
3. انتظر حتى يبرد الصنبور: للحفاظ على كفاءة الصنبور مع مرور الوقت، استخدم إبرة التنظيف (C11) من أجل الحفاظ على الـ 3 فتحات حرة (الشكل 24).

6. قم بتخصيص طول مشروبات القهوة بالزر (my) (B7)

1. قم بإعداد الماكينة لإخراج فنجان أو فنجانين من مشروب القهوة المراد إخراجه، حتى تعشيق حامل المرشح (C1) المزود بالمرشح (C2) أو (C3) والبن المطحون.
2. قم بلف المقبض (B8) لاختيار المشروب المراد برمجته.
3. اضغط على المفتاح (my): يوضع المؤشر الموافق للمفتاح (my).
4. اضغط على الزر OK لبدء عملية السكب. تومض المؤشرات الضوئية المقابلة للمفتاح OK و (my).

- إذا كانت القهوة تحت/فوق مستوى السحب المحدد والكمية في الداخل مثالية فإنه يجب ضبط درجة الطحن لجعلها أكثر نعومة أو أكثر كثافةً (انظر «4.1 المرحلة 1 - الطحن (grinding)»). إذا كانت القهوة فوق مستوى السحب (عملية السكب تتم ببطء مفرط) فإن عملية الطحن ينبغي أن تكون أكثر كثافةً. إذا كانت القهوة تحت مستوى السحب (عملية السكب تتم بسرعة مفرط) فإن عملية الطحن ينبغي أن تكون أكثر نعومة.
- **يوصى عامل البار بما يلي:** أخرج حامل المرشح بينما يكون ذراع ضاغط القهوة (A20) مزل للحصول على الشكل المثالي لكمية القهوة.
- **في حالة استخدام بن مطحون مسبقاً:**

- قم بصب البن المطحون مسبقاً في المرشح;
- أدر المقبض على
- قم بتثبيت حامل المرشح في مخرج مطحنة البن;
- أنزل ذراع الضغط.

4.3 المرحلة 3 - الصب (brewing)

1. اختر درجة الحرارة (شكل 20) «درجة حرارة إعداد القهوة».
2. اختر المشروب المرغوب فيه (الشكل 21).
3. اضغط على OK (B5) لبدء عملية السكب (الشكل 11) (ما قبل النقع وعملية النقع). تتوقف عملية سكب القهوة بشكل تلقائي.

درجة حرارة إعداد القهوة

تتم مراقبة درجة حرارة الماء أثناء عملية التحضير بأكملها لضمان ثباتها أثناء مرحلة الاستخراج. يقدم Prestigio Specialist 3 درجات حرارة للنقع* والتي تتوافق مع نطاق يتراوح بين 92° مئوية و 96° مئوية. بناءً على نوعية الحبوب وتحميصها، ننصح بدرجة حرارة مختلفة: تتطلب حبوب روبوستا درجة حرارة منخفضة؛ بينما تتطلب حبوب البن العربي درجة حرارة عالية. يسري نفس الأمر على الحبوب ذات التحميص الداكن أو الحبوب المحمصّة للتو.

مستوى الحرارة	المؤشر الموافق	مستوى التحميص
MIN (الحد الأدنى)		Scuero (داكن)
MED (متوسط)		Medio-scuero (متوسط-داكن)
MAX (الحد الأقصى)		Chiuro - scuero (فاتح - داكن)

* تشير درجة الحرارة هذه إلى الماء في الكتلة الحرارية. وبالتالي فإنها تختلف عن درجة حرارة المشروب في الفنجان أو عن درجة الحرارة المقاسة عندما يخرج المشروب من صناير حامل المرشح.

5. إعداد مشروبات الحليب

5.1 قم بترغية الحليب

1. قم بصب كمية الحليب المراد تسخينها/ترغيتها في الإبريق (C10)، مع الأخذ في الاعتبار أن حجم الحليب سيزداد بمقدار 2 أو 3 مرات (الشكل

اضبط كمية البن المطحون في المرشح

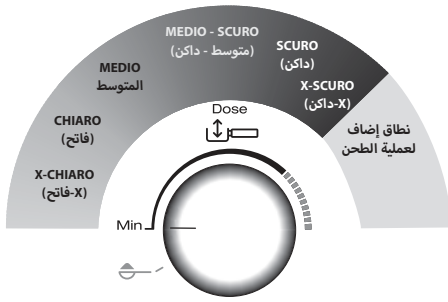

أي تغيير في نوع حبوب القهوة يعطي نتيجة مختلفة أثناء عملية الطحن ولذلك تحتاج عملية ضبط الكمية في البداية إلى انتباه ودقة كبيرين. يقدم هذا الرسم التوضيحي بعض الإرشادات حول كيفية ضبط الكمية وهذه الإرشادات قائمة على لون التحميص: ينبغي اعتبارها نقاط إرشادية كدبابة ولكن قد تختلف وفقاً لتركيبة حبوب القهوة.

1. اضبط الكمية من الحد الأدنى.
2. مع الاسترشاد بلون تحميص القهوة الخاصة بك، قم بلف المقبض ببطء.

4.2 المرحلة 2 - الضغط (tamping)

1. بعد الطحن، أزل ذراع الضغط (A20) حتى نهاية مساره (لا تقم بإزالة حامل المرشح (الشكل 17). للحصول على نتيجة مثالية، كرر هذه العملية لمرتين.
 2. حافظ على إبقاء الذراع منزلًا حتى حاجز نهاية مساره أثناء إزالة حامل المرشح (الشكل 18). أعد بعد ذلك ذراع الضغط إلى وضعه البداية.
 3. بعد التحقق من أن كمية القهوة صحيحة (انظر «الكمية المثالية»)، قم بتعشيق حامل المرشح في موّج سكب القهوة (A18) (الشكل 19).
- انتبه جيدًا!** بعد الضغط، إذا ظلت بعض بقايا البن على حواف المرشح، فلن يضر ذلك مطلقاً بجودة الاستخراج وبالتالي بالنتيجة النهائية.

"الكمية المثالية"

- تمتلك مرشحات القهوة علامة داخلية للإشارة إلى الجرعة المثالية.

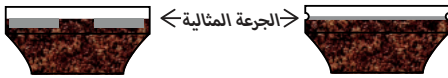

- المرشحات ذات العلامة المنفذة بالليزر: تتوافق الجرعة المثالية مع الخط العلوي للعلامة؛
- المرشحات ذات العلامة البارزة: تتوافق الجرعة المثالية مع الخط البارز؛

تحتوي مرشحات القهوة على نظام علامات تحديد داخلي يعمل بالليزر لتحديد مستوى الكمية المثالية. يتوافق الحد الأدنى للكمية مع الخط السفلي لنظام علامات التحديد؛ يتوافق الحد الأقصى للكمية مع الخط العلوي من نظام علامات التحديد. الكمية المثالية توجد في داخل هذين الخطين.

تحقق من أن القهوة في المستوى المطلوب بعد عملية الضغط. قد يصبح من الضروري ضبط المقبض (B2) لأكثر من مرة قبل الوصول إلى الكمية المثالية.

5. ضح حاوية تحت كأس حامل المرشح وأنبوب صب البخار (A6)؛

6. اضغط على المفتاح (B5) OK (شكل 11)؛ سيبدأ التوزيع؛

7. عقب الانتهاء من التوزيع، أدر مقبض البخار (A4) (الشكل 12) وقم بتوزيع البخار لبضع ثوان بحيث تشطف دائرة البخار: للحصول على عملية توزيع مثالية للبخار يُصح بتكرار هذه العملية 3 أو 4 مرات. يسمح ذلك بإزالة الماء في الأنبوب قبل سكب البخار.

هكذا صار الجهاز في وضعية الاستعداد للاستخدام. انتبه جيدًا: تُعد عملية شطف دواخل الماكينة ضرورية للغاية أيضًا في حالة إطالة مدة استعمال الجهاز.

عند الاستخدام الأول، من الضروري إعداد 3-5 فناجين من القهوة قبل أن يبدأ الجهاز في إعطاء نتائج مرضية؛ يجب إيلاء اهتمام خاص لجرعة البن المطحون في المرشح (C2) أو (C3) (انظر التعليمات الواردة في الفقرة 4.1 المرحلة 1 - الطحن (grinding)).

تابع كما هو موضح في الفصل «الكمية المثالية».

4.4 رقم ياعداد القهوة

4.1 المرحلة 1 - الطحن (grinding)

• اسكب حبوب البن في الوعاء (A2) (الشكل 13). يُصح بسكب فقط حبوب القهوة الضرورية لعملية الإعداد: بهذه الطريقة ستحصل دائمًا على قهوة طازجة؛

2. حدد درجة الطحن (الشكل 14). درجة ضبط المصنع هي 5 (طحن متوسط). إذا لم تكن نتيجة الطحن مرضية بالنسبة لك، قم بضبط مستوى الطحن وفقًا لذوقك ونوع القهوة (يجب إجراء عملية الضبط أثناء عمل مطحنة البن).

انتبه جيدًا! يُصح بدرجة الطحن بين 3 و 6 لمعظم أنواع البن. نتيجة الطحن مع اختيار 1 أو 2، تكون ناعمة جدًا، لا يجب استخدامها إلا مع بن خاص جدًا (المحمص الخفيف).

• أدخل أحد مرشحات القهوة (C2) أو (C3) في حامل المرشح (C1) (الشكل 15). في حالة استخدام المرشح لفنجانين، اضغط على الزر (B3) (X2)؛ ستقوم من خلال هذا الاختيار بمضاعفة كمية الإسبريسو المسكوبة.

4. اضبط مقبض تحديد الكمية (B2) بدءًا من وضعية الحد الأدنى (الشكل 16).

يُرجى العودة إلى الفقرة «اضبط كمية البن المطحون في المرشح» للحصول على مزيد من المعلومات التفصيلية.

5. قم بتثبيت حامل المرشح بمخرج مطحنة البن (A19) عن طريق محاذاته بالكتابة INSERT (إدخال)؛ ثم أدر الكأس تجاه اليمين. تبدأ عملية الطحن عندما يصل الكوب إلى الوضع "علق" CLOSE وتتوقف تلقائيًا.

1. الوصف

1.1 وصف الجهاز - A

- A1. غطاء وعاء الحبوب
- A2. وعاء الحبوب
- A3. حامل فناجين القهوة
- A4. مقبض البخار
- A5. فوّهة صب الماء الساخن
- A6. أنبوب توزيع البخار
- A7. شبكة حمل فناجين الإسبرسو
- A8. شبكة حمل الكؤوب أو المِج
- A9. شبكة الحوض
- A10. وعاء تجميع قطرات الماء
- A11. مؤشّر مستوى الماء في حوض تجميع القطرات
- A12. غطاء خزّان الماء
- A13. مقبض استخراج خزان الماء
- A14. خزّان الماء
- A15. موضع مرشح تنقية الماء
- A16. مكان موصل كابل التيار الكهربائي
- A17. قاطع التيار العمومي (تشغيل/إيقاف "ON/OFF")
- A18. مؤرّج سكب القهوة
- A19. مخرج مطحنة البن (Tamping station)
- A20. ذراع الضغط
- A21. منفذ صغير للوصول إلى منزلق مطحنة البن

1.2 وصف لوحة التحكم - B

- B1. زر التشغيل/الاستعداد
- B2. مقبض ضبط كمية البن المطحون
- B3. الزر "X2": لاستخدام المرشح 2 للقهوة
- B4. زر "درجة الحرارة حرارة القهوة"
- B5. زر "OK": لإخراج المشروب/التأكيد
- B6. زر "سكب الماء الساخن"
- B7. زر "My": من أجل تخصيص طول المشروبات
- B8. مقبض اختيار الوظائف

- Espresso
- قهوة أمريكية
- Coffee
- إزالة الترسبات الكلسية
- B9. مؤشّر "إزالة الترسبات الكلسية"
- B10. مؤشّر "استعداد البخار"
- B11. مؤشّر "نقص حاوية حبوب القهوة"
- B12. مؤشّر "توفير الطاقة"
- B13. مؤشّر "النظافة" (انظر 8.1 تنظيف موزع سكب القهوة)
- B14. مؤشّر "حاوية حبوب القهوة فارغ"
- B15. مؤشّر "نقص الماء"
- B16. مؤشّر "الضغط"
- B17. مقياس الضغط

1.3 وصف الملحقات التشغيلية - C

- C1. كأس حامل المرشّح
- C2. مرشح 1 فنجان
- C3. مرشح 2 فنجان
- C4. شريط الاختبار «Total Hardness Test» (قسوة المياه)
- C5. مزيل الترسبات الجيرية
- C6. كابل تغذية قابل للإزالة
- C7. فرشاة تنظيف
- C8. ملحق تنظيف مؤرّج سكب القهوة
- C9. Softballs
- C10. حاوية الحليب
- C11. إبرة تنظيف لذرّاع البخار

1.4 الملحقات التشغيلية الخاصة بالتنظيف لا تأتي مع الجهاز

وهي موصى عليها من قبل الشركة المصنّعة

للحصول على مزيد من المعلومات حول ذلك، قمر بزيارة Delonghi.com.

قرص تنظيف

(انظر «8.1 تنظيف موزع سكب القهوة»)



المنظف EcoMultiClean

الرمز الشريطي: 8004399333307

2. إعداد الماكينة

اغسل جميع الملحقات بماء فاتر ومنظف أطباق، ثم اتبع الخطوات التالية:

1. أدخل وعاء الحبوب (A2) في مطحنة البن (الشكل 1). يتم إدخال الوعاء بشكل صحيح عندما يكون السهم ▲ محاذاً للرمز □ وتُسمع "نقرة" (الشكل 2).
2. أدخل صينية تجميع القطرات (A10) كاملة مع شبكة حمل الفناجين (A8) وشبكة الحوض (A9) (الشكل 3)؛
3. أزل خزان الماء (A14) (الشكل 4) وأعد ملئه بماء بارد ونظيف مع الانتباه إلى عدم تجاوز الكتابة MAX (الشكل 5).
4. ثم أعد إدخال الخزان.

تنبيه: لا تشغّل مطلقاً الجهاز بدون صب الماء أولاً في الخزّان أو بدون وجود خزان. اتبه جيّداً: يُسمح بتعديل في أسرع وقت ممكن درجة مستوى المعادن في الماء باتّباع الإجراءات التي تُر وصفها بالتفصيل في فقرة «7. قائمة إعدادات الضغط».

3. استعمال الجهاز لأول مرة

1. أدخل موصل كابل التغذية (C6) في الموضع المخصص له (A16) خلف الجهاز (الشكل 6)؛ ثم أدخل القابس في مأخذ التيار. تحقق من الضغط على قاطع التيار العام (A17)، الموجود خلف الجهاز في الوضع I (الشكل 7)؛
2. ضع تحت صنوبر الماء الساخن (بجانب صنوبر القهوة (A18)) وعاءً لا تقل سعته عن 100 مل (الشكل 8)؛
3. اضغط الزر (B6) بمحاذاة مؤشّر (B) (الشكل 9): يبدأ صرف القهوة ويتوقف تلقائياً. قمر بإفراغ الحاوية.
- قبل البدء في استخدام الماكينة، يلزم شطف الدوائر الداخلية للماكينة. اتبع الخطوات التالية:
4. قمر بتثبيت كوب حامل المرشح مزوداً بمرشح (C1) بالماكينة: من أجل الحصول على التثبيت الصحيح، قمر بمحاذاة مقبض كوب حامل المرشح مع الرمز "INSERT" (الشكل 10) وأدر المقبض نحو اليمين، حتى محاذاة الوضع "CLOSE":

Register Now 
www.delonghi.com/register

